

Product Specifications



Designed for Quality

R ROTOR CLIP[®]

Price: \$2.00 U.S.



ROTOR CLIP COMPANY, INC.[®]

Certified to ISO/TS 16949:2009, ISO 9001:2008



www.rotorclip.com

Rotor Clip Company, Inc.[®] - World Headquarters

187 Davidson Avenue, Somerset, NJ 08873
1-800-557-6867 • +1 732-469-7333 • Fax: +1 732-469-7898
e-mail: sales@rotorclip.com • www.rotorclip.com

Rotor Clip Limited[®]

Unit 6, Meadowbrook Park, Holbrook, Sheffield, S20 3PJ United Kingdom
+44 (0) 114 247 3399 • Fax: +44 (0) 114 247 4499
e-mail: rcltd@rotorclip.com • www.rotorclip.co.uk

Rotor Clip GmbH[®]

Wiesbadener Str. 73, D-65510 Idstein/Taunus Germany
+49 (0) 6126 227360 • Fax: +49 (0) 6126 2273619
e-mail: rcgmbh@rotorclip.com • www.rotorclip.de



© Copyright 1985, 1986, 1987, 1989, 1991, 1993, 1994, 1996, 1998, 2002, 2007, 2010 Rotor Clip Company, Inc.

Table of Contents

Product Index.....	2-3	ANSI Metric Tapered Section Retaining Rings		Wave Springs	
Rotor Clip: Your Single Source.....	4	MHO.....	100-105	SST.....	208-209
Ring Attributes.....	5	MSH.....	106-109	NST.....	210
Part Numbers & Packaging.....	6	MSR.....	110-111	MST.....	211-212
rotorclip.com - Online Ordering.....	7	ME.....	112-113	MST Bearing Interchange.....	213
Materials: Tapered/Constant Section Rings.....	8	MC.....	114-115	WSL/WSM/WSR.....	214-222
Finishes: Tapered/Constant Section Rings.....	9	MRE.....	116-117	MWL/MWM/MWR.....	223-234
Materials/Finishes: Spiral Rings.....	10				
Wave Springs.....	11	JIS “E” Retaining Rings		Shims	
Hose Clamps.....	12	JE.....	118	KMS.....	235
Interchange Chart.....	13				
		Inch Constant Section Retaining Rings		Self-Compensating Hose Clamps	
Inch Tapered Section Retaining Rings		HN.....	119	HC.....	236
(Axially Assembled)		UHO.....	120-121	HW.....	237
HO.....	14-19	UHB.....	122-124	DW.....	238
SH.....	20-25	USC.....	125-127	CTB.....	239
HOI.....	26-27	USH.....	128	CTL.....	240
SHI.....	28-29	SNL.....	129	CTO.....	241
SHR.....	30-31	SLC/SLO; SHC/SHO.....	130		
SHM.....	32-33	RLC/RLQ; RHC/RHO.....	131	Tools/Kits	
BHO.....	34-35			Standard Retaining Ring Pliers.....	242
BSH.....	36-37	Metric Constant Section Retaining Rings		Ratchet Retaining Ring Pliers.....	243
VHO.....	38-43	HBL/HBM/HBH.....	132-133	Grip Ring Pliers.....	243
VSH.....	44-47	SR.....	134	Convertible Retaining Ring Pliers.....	244
		SB.....	135	Heavy Duty Retaining Ring Pliers.....	244
Inch Tapered Section Retaining Rings		CFS.....	136-138	Dispensers.....	245
(Radially Assembled)		CFH.....	139-142	Applicators.....	246-247
E.....	48-49	CBS (DIN 5417).....	143-144	Automatic Assembly Tools (Ring).....	248
RE.....	50-51	CRS (DIN 7993).....	145	Hose Clamp Tools (Manual).....	248
C.....	52-53	CRH (DIN 7993).....	146	Hose Clamp Tools (Pneumatic).....	249
LC.....	54-55	Cutoff Styles.....	147	Retaining Ring Plier Kits.....	250
PO/POL.....	56-57			Retaining Ring Kits.....	250
BE.....	58-59	Inch Spiral Retaining Rings			
EL.....	60-61	KL.....	148-149	Technical Information	
		CL.....	150-151	Automated Assembly (Axial Rings).....	251
Inch Tapered Section Retaining Rings		KM.....	152-155	Load Capacity Formulas.....	252-259
(Self-Locking)		CM.....	156-159	Static Thrust Loads.....	252-255
SHF.....	62-63	KR.....	160-161	Allowable Thrust Loads - Rings.....	252
RG.....	64	CR.....	162-163	Allowable Thrust Loads - Grooves.....	252
TX.....	65	KG.....	164-167	Calculating Edge Margin.....	253
TY.....	66	CG.....	168-171	Thickness of Housings/Hollow Shafts.....	254
TI.....	67	KLR.....	172-173	Load Limit Formulas.....	254-255
		CLR.....	174-175	Dynamic Thrust Loads.....	256-257
Metric Tapered Section Retaining Rings				Sudden Loading.....	256
DHO (DIN 472).....	68-75	Metric Spiral Retaining Rings		Impact Loading.....	256
DHI.....	76-77	DKR (DIN 472).....	176-179	Vibration Loading.....	256-257
DHT (DIN 984).....	78-79	DCR (DIN 471).....	180-181	Corner Radii and Chamfers.....	257-258
DHR (DIN 472 - Heavy Type).....	80	DKL.....	182-183	Elastic Deformation.....	258
DSR (DIN 471 - Heavy Type).....	81	DCL.....	184-185	Relative Rotation.....	259
DSH (DIN 471).....	82-89	KLM.....	186-187	Deflection.....	259
DSI.....	90-91	CLM.....	188-189	Beveled Retaining Rings.....	260
DST (DIN 983).....	92-93	MKM.....	190-191	Bowed Retaining Rings.....	261
DE (DIN 6799).....	94	MCM.....	192-193	Inspection Procedures.....	262-264
DSF.....	95	MKR.....	194-195	Determining Permanent Set Limits.....	262
DC.....	96-97	MCR.....	196-197	Dish, Pitch & Burr Limitations.....	263
DTX.....	98	MKG.....	198-199	For Constant Section Retaining Rings.....	264
DTI.....	99	MCG.....	200-201	Constant Section Ring “Kick-In” Feature.....	264
		MKA (Aerospace).....	202-203	Definitions (Retaining Ring).....	265
		MCA (Aerospace).....	204-205	Design Considerations (Retaining Ring).....	266-267
				Military Retaining Rings.....	268
		TruWave™ Spiral Rings		Lot Traceability / Quality.....	269
		NKG.....	206	Joint Design Guide - Hose Clamps.....	270-271
		NCG.....	207		



Product Index

Axially Assembled, Inch Tapered Section Retaining Rings

Internal

External



HO
Page 14-19



HOI
Page 26-27



BHO
Page 34-35



VHO
Page 38-43



SH
Page 20-25



SHI
Page 28-29



SHR
Page 30-31



SHM
Page 32-33



BSH
Page 36-37



VSH
Page 44-47

Radially Assembled, Inch Tapered Section Retaining Rings

External



**E/SE/
YE/ZE**
Page 48-49



RE
Page 50-51



BE
Page 58-59



C
Page 52-53



LC
Page 54-55



PO/POL
Page 56-57



EL
Page 60-61

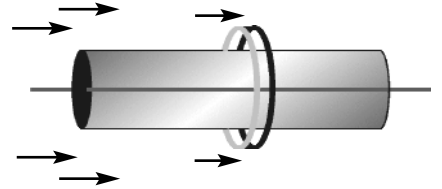

Axially Installed

Self-Locking, Inch Tapered Section Retaining Rings

External

Internal



SHF
Page 62-63



RG
Page 64



TX
Page 65



TY
Page 66



TI
Page 67

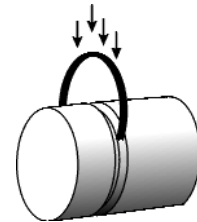

Radially Installed

Axially Assembled, Metric Tapered Section Retaining Rings

Internal

External



DHO
DIN 472
Page 68-75



DHI
Page 76-77



DHT
DIN 984
Page 78-79



DHR
Page 80



DSH
DIN 471
Page 82-89



DSI
Page 90-91



DST
DIN 983
Page 92-93



DSR
DIN 471
Heavy Type
Page 81

Radially Assembled, Metric Tapered Section Retaining Rings

External



DE
DIN 6799
Page 94



DC
Page 96-97

Self-Locking, Metric Tapered Section Retaining Rings

External

Internal



DSF
Page 95



DTX
Page 98



DTI
Page 99

JIS "E" Retaining Rings

External



JE
JIS B 2805
Page 118

Axially Assembled, ANSI Metric Tapered Section Retaining Rings

Internal External



MHO
Page 100-105



MSH
Page 106-109



MSR
Page 110-111

Self-Locking, Metric Tapered Section Retaining Rings

External



ME
Page 112-113



MC
Page 114-115



MRE
Page 116-117



Inch Constant Section Retaining Rings

Internal

External

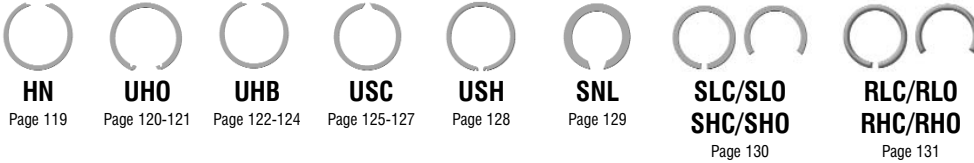

Metric Constant Section Retaining Rings

Internal

External

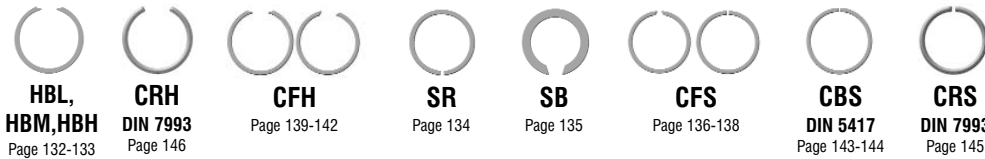

Shims

Internal/External



Inch Spiral Retaining Rings

Internal

External



TruWave™ Rings

Internal External



Metric Spiral Retaining Rings

Internal

External

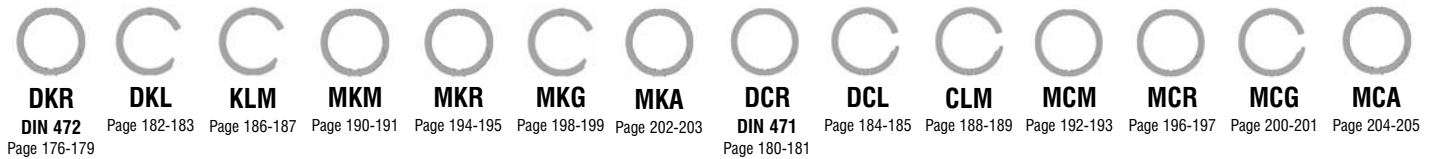

Wave Springs

Single Turn

Multi Turn

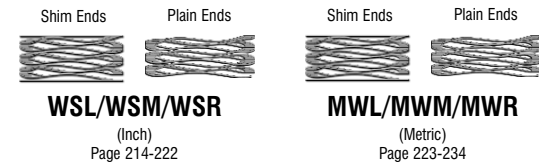

Self-Compensating Hose Clamps

Wire Clamps

Band Clamps

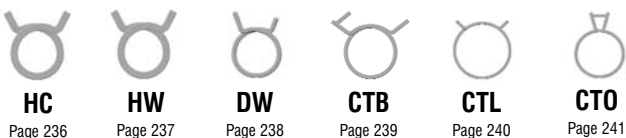



All Rings Have A Function...

A discussion of retaining rings must inevitably begin with a debunking of myths; namely, that one style retaining ring will function better than all other types in all instances. No one retaining ring style is “better” than another. Rather, the parameters of an application actually determine which retaining ring is best to use, and this can vary from assembly to assembly. Selecting the correct type of retaining ring based on variables such as installation/removal requirements, anticipated thrust load, and end play take-up can ensure the retaining ring you choose will perform reliably, while significantly reducing fastener costs.

There are three main types of retaining rings available to the designer: **tapered, constant section and spiral**. These are typically made from carbon steel, stainless steel or beryllium copper and feature a variety of finishes for corrosion protection (see accompanying table). Again, the final selection of a type and size retaining rings depends upon these and the previously mentioned parameters.

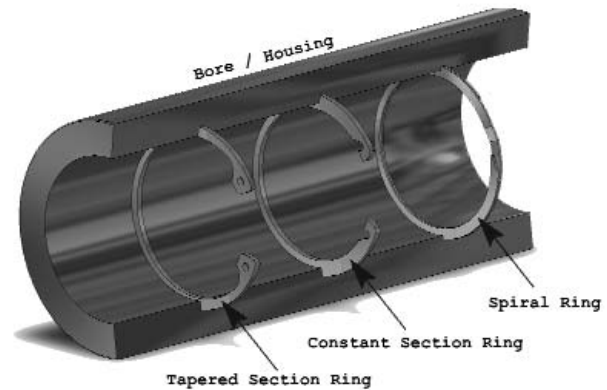

The following are some points to take into consideration when choosing a ring. Our engineers work with you to find the right type of ring for your design.



TAPERED SECTION

Tapered section rings make uniform contact with the groove, with a gap between the lugs.



CONSTANT SECTION

Constant section rings are elliptical when installed in the groove, making only 3-point contact as illustrated



SPIRAL RINGS

Spiral rings make 360° contact with the groove

**For Technical Assistance,
e-mail tech@rotorclip.com**

The Right Ring For Your Application



TAPERED SECTION RETAINING RINGS - Axially Assembled:

- Axially installed into machined grooves in housings/bores (internal) or on shafts (external)
- Have lug holes for ease of installation/removal
- Make uniform contact when released in a groove
- Can accommodate higher thrust loadings
- Provide more of a shoulder with which to retain a component or assembly than constant section or spiral retaining rings

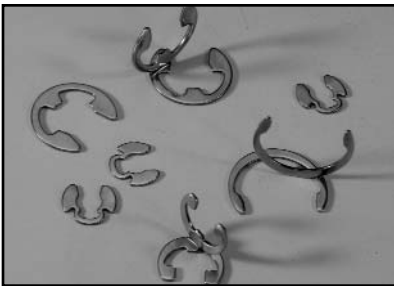

TAPERED SECTION RETAINING RINGS - Radially Assembled:

- Radially installed into machined grooves on shafts (external)
- Accommodate lower thrust loadings than axial retaining rings
- Do not have lug holes: Easy to install using retaining ring applicators
- Provide protruding “shoulders” for effective retention of assemblies
- Economical alternative to Axially Assembled external tapered section rings

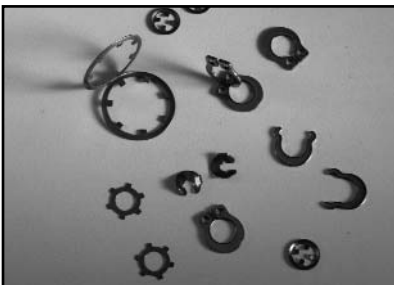

TAPERED SECTION RETAINING RINGS - Self Locking:

- Can be installed on a shaft or in a housing/bore without a groove
- Save on machining time and costs since no groove is needed
- Can be used effectively and economically on small applications
- Accommodate low thrust loadings
- Difficult to remove once installed

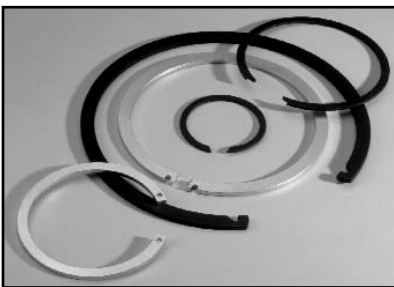

CONSTANT SECTION RETAINING RINGS:

- Axially installed into machined grooves in housings/bores (internal) or on shafts (externally)
- Offer more clearance than a tapered section ring
- Accommodate less force than a tapered section ring
- Uniform material width is elliptical when installed in a groove, making 3 point contact
- More difficult to install/remove
- Economical alternative to tapered section rings depending on the application

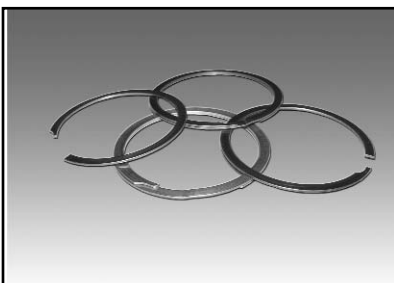

SPIRAL RETAINING RINGS:

- Axially installed into machined grooves in housings/bores (internal) or on shafts (external)
- Make 360° contact with a groove in a housing/bore or shaft
- Accommodate less force than a tapered section ring
- Offer more clearance than a tapered section ring
- More difficult to install/remove



Part Numbers & Packaging

ROTOR CLIP PART NUMBER

HO-50 ST PA S

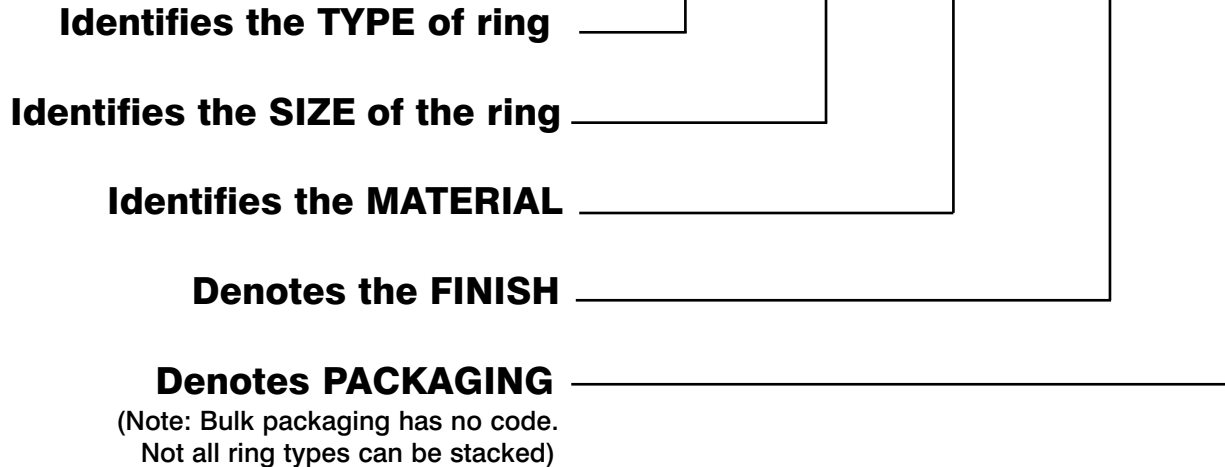

Materials Codes:

- ST** Carbon Steel
- SS** Stainless Steel (PH15-7, PH-17-7)
- SC** Stainless Steel 420
- SG** Stainless Steel DIN 1.4122
- BC** Beryllium Copper
- PB** Phosphor Bronze

Finishes Codes:

- PA*** Phosphate
- PD*** Phosphate & Oil
- PAL*** Phosphate with Sealer
- HPD*** Heavy Phosphate & Oil
- ZD** Zinc Dichromate
- ZDL** Zinc Dichromate with Sealer
- ZF** Zinc Bright
- Z3X*** Trivalent Chromate Zinc Plus Sealer
- ZFF**** Zinc Flash
- CF**** Copper Flash
- OIL*** Oil Over Steel (Constant Section Rings)

Packaging Codes:

- No Code** Bulk
- S** Tape Stacked
- RO1** Plastic Shrink Wrapped

Note: **Rings on Wire, or ROW** (pictured right) is standard bulk packaging for certain rings. Contact factory for more details.

* *These finishes are RoHS compliant.*
** *For identification only. Does not provide corrosion protection.*





Materials Tapered/Constant Section Rings

Standard material for Rotor Clip retaining rings is carbon spring steel (SAE 1060-1090/UNS G10600-G10900). Rings can also be produced in our standard stainless steel (PH 15-7 Mo/UNS S15700) with 420 type cold rolled stainless steel (UNS S42000) as an option and in our standard beryllium copper (Alloy #25/UNS C17200) with copper alloy C72900 and phosphor bronze (Alloy#5218/UNS C52180) as options.

Please note that the availability of rings in the stainless steel and copper materials is subject to prior inquiry and acceptance of a formal quotation.

Rotor Clip can also produce rings one gauge thicker or thinner than standard sizes. Again, such orders are subject to prior inquiry and acceptance of a formal quotation.

Characteristics of each material follow:

CARBON SPRING STEEL - This steel is known for its high strength, and reliability in retaining ring applications. Since carbon spring steel is subject to corrosion, Rotor Clip treats all such rings with a protective coating to ensure some corrosion resistance. For long-term corrosion protection, a zinc plating or non-metallic finish should be applied over the steel. (See "Finishes" section).

STAINLESS STEEL -

• **PH 15-7 Mo** is an extra strength corrosion-resistant steel, capable of preventing atmospheric oxidation at temperatures up to 900° F. It also offers the following advantages:

1. Minimal distortion due to unique heat-treating process.
2. A minimum of 225,000 psi for high ultimate tensile strength.
3. High creep strength.

Note: We reserve the right to substitute PH 17-7 stainless steel material for PH 15-7 Mo on larger rings.

• **TYPE 420** - A less expensive alternative to PH 15-7. Since general corrosion resistance for this material is less than PH-15-7, use of this material depends upon the application. Contact Technical Sales for assistance.

• **DIN 1.4122** - A grade of stainless steel for retaining rings ordered in / for European countries.

BERYLLIUM COPPER ALLOY#25 - Applications that require conductivity are best served by this material. It is also characterized by excellent corrosion resistance and is particularly effective in sea air and seawater atmospheres.

PHOSPHOR BRONZE ALLOY#5218 - The least expensive copper material Rotor Clip offers. This type exhibits higher strength compared to standard phosphor bronze materials with the same tin percentages. It is also characterized by very good stress relaxation characteristics. (Note: Rotor Clip can also supply phosphor bronze material to DIN standard 17 662, Material Number 2.1020. Contact Rotor Clip Technical Sales for more information).

Material	Rotor Clip Code
Carbon Spring Steel SAE 1060-1090 (UNS G10600-G10900)	ST
Stainless Steel PH 15-7 Mo (Grade 632 - UNS S15700) 17-7 PH (Grade 631 - UNS S17700) 420 (UNS S42000) DIN 1.4122	SS SS* SC SG
Beryllium Copper UNS C17200	BC
Phosphor Bronze UNS C52180	PB

*Note: Large stainless steel rings may be supplied from 17-7 due to material availability. Contact factory for details.



Tapered/Constant Section Rings **Finishes**



PHOSPHATE COATING (PA) - This standard finish is recommended over unfinished plain steel since it offers an extended shelf-life protection against rusting. RoHS compliant. **THERE IS NO ADDITIONAL CHARGE FOR THIS FINISH.**

PHOSPHATE AND OIL (PD) - This finish provides 8-hour salt spray protection. RoHS compliant.

PHOSPHATE WITH SEALER (PAL) - A coating is added to the finish to control loose phosphate crystals on the surface of the part. RoHS compliant.

HEAVY PHOSPHATE AND OIL (HPD) - This finish provides 72 salt spray hours and can be used in place of costly stainless steel material in some applications. (Contact Rotor Clip Technical Sales for more information). RoHS compliant.

ZINC PLATING (ZD) - This coating features a yellow dichromate post plating finish. It affords the metal excellent salt spray protection (96 hours) and is particularly effective for applications exposed to seawater. Rotor Clip SAE 1060-1090 steel retaining rings are zinc plated using a mechanical plating process, which effectively eliminates hydrogen embrittlement.

ZINC BRIGHT (ZF) - Most of the dichromate is leached out of this process, leaving a "bright" silver finish on the parts. ZF offers some corrosion protection (48 hours), but is widely used when the aesthetics of the part are a factor.

ZINC DICHROMATE w/SEALER (ZDL) - This improved finish offers corrosion protection of up to 240 hours of salt spray protection. (**Heavy Zinc Dichromate with Sealer - HZDL** - offers 480 hours of salt spray protection.) It is a low cost substitution for costly non-corrosive materials such as stainless steel in some applications. Call for additional information.

TRIVALENT CHROMATE over ZINC (Z3X) - This coating meets global requirements for hexavalent-free coatings. **Z3X**, trivalent with a sealer, affords 240 salt spray hours of protection. RoHS & ELV compliant.

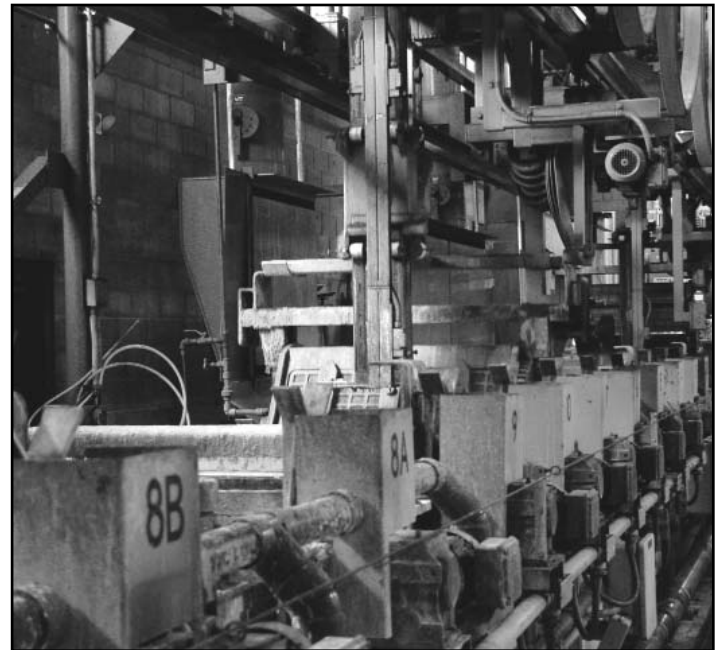

OIL OVER STEEL (OIL) - Used for Constant Section Rings, an oil finish is applied over carbon steel to offer an extended shelf-life protection against rusting. No salt spray protection. RoHS compliant.

Finish	Code	Description	Salt Spray Hours	Color
Phosphate	PA	Shelf-Life	-	Black
	PD	Phosphate and Oil	8 (Red Rust)	Black
	PAL	Phosphate with Sealer	-	Black
	HPD	Heavy Phosphate and Oil	72 (Red Rust)	Black
Hexavalent Chrome	ZF	Zinc Bright	48 (Red Rust)	Silver
	ZD	Zinc Dichromate	96 (Red Rust)	Yellow
	ZDL	Zinc Dichromate Sealer	240 (Red Rust)	Yellow
	HZDL	Heavy Zinc Dichromate Sealer	480 (Red Rust)	Yellow
Trivalent	Z3X	Trivalent Chromate Zinc plus Sealer	96/240*	N/A
Optional Color Coding Finishes	ZFF	Zinc Flash	None	Silver
	CF	Copper Flash	None	Copper
	OIL	Oil Over Steel - Shelf Life	-	Black

* White Corrosion/Red Corrosion

NOTE: Electroplating can not be successfully done with steel retaining rings due to the problems encountered with hydrogen embrittlement.





Materials/Finishes Spiral Rings

Materials:

CARBON SPRING STEEL

This steel is known for its high strength and reliability in spiral ring applications. Since carbon steel is subject to corrosion, Rotor Clip rings are oil dipped to ensure some corrosion resistance.

STAINLESS STEEL - AISI 302

This general purpose stainless steel offers corrosion resistance and can be cold worked to high tensile strengths.

STAINLESS STEEL - AISI 316

This type of stainless steel is heat resistant with superior corrosion resistance than other chromium nickel steels. It offers high creep strength at elevated temperatures and resistance to pitting.

STAINLESS STEEL - PH17-7

A high strength corrosion-resistant steel with good workability, easy hardening and excellent mechanical properties at elevated temperatures. Can be heat treated at relatively low temperatures for high strength properties.

BERYLLIUM COPPER

Applications that require conductivity are best served by this material. It is also characterized by excellent corrosion resistance and is particularly effective in sea air and seawater atmospheres

Finishes:

OIL DIP

This standard finish for carbon steel spiral retaining rings offers an extended shelf-life protection against rusting.

BLACK OXIDE

This flat, black finish is used more for when aesthetics of the part are a factor with minimal corrosion protection.

CADMIUM PLATING

This protective coating offers excellent corrosion protection, ductility, natural lubricity and solderability in specialized applications.

PASSIVATION

The passivation process removes "free iron" contamination left behind on the surface of stainless steel due to the manufacturing process. Also, the passivation process facilitates the formation of a thin, transparent oxide film that protects the stainless steel from selective oxidation (corrosion).

ZINC PHOSPHATE

This coating affords carbon steel excellent salt spray protection and corrosion resistance.

Material	Material Thickness (in)	Minimum Tensile Strength (psi)	Shear Strength (psi)	Maximum Recommended Operating Temperature °F	Modulus of Elasticity (psi)
CARBON STEEL OIL TEMPERED SAE 1070 - 1090	.006 - .014	269,000	153,000	250	30 x 10 ⁶
	.0141 - .021	255,000	145,000		
	.0211 - .043	221,000	126,000		
	.0431 & larger	211,000	120,000		
CARBON STEEL HARD DRAWN SAE 1060 - 1075	.006 to .030	230,000	130,000	400	28 x 10 ⁶
	.0301 - .110	181,000	103,000		
	.1101 - .220	156,000	89,000		
AISI 302 AMS-5866	.002 - .022	210,000	119,000	400	28 x 10 ⁶
	.0221 - .047	200,000	114,000		
	.0471 - .062	185,000	105,000		
	.0621 - .074	175,000	100,000		
	.0741 - .089	165,000	94,000		
	.0891 - .095	155,000	88,000		
AISI 316 ASTM A313	.002 - .023	195,000	111,000	400	28 x 10 ⁶
	.0231 - .048	190,000	108,000		
	.0481 - .061	175,000	99,000		
	.0611 & larger	170,000	97,000		
17-7 PH/C CONDITION CH900 AMS-5529		240,000 ²	137,000 ²	650	29.5 x 10 ⁶
BERYLLIUM COPPER TEMPER TH02 ASTM B197		185,000 ²	128,000 ²	400	18.5 x 10 ⁶



Wave Springs **TRU** **WAVE**™

WAVE SPRING ADVANTAGE

Using wave springs can reduce traditional coil spring heights as much as 50% saving weight and costs as well as reducing overall assembly sizes.

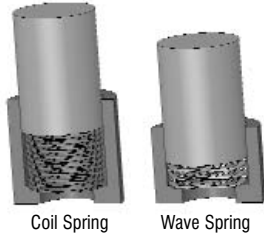

WAVE SPRING TYPES:

GAP SINGLE TURN/OVERLAP SINGLE TURN

Standard Inch (SST) / Narrow Inch (NST) / Metric (MST)

- Ideal for short deflection applications with low to medium forces.
- Offered in a number of waves and material thicknesses.
- Designed for a wide range of bore and rod diameters.
- Ideal for:
 - Narrow radial wall dimensions
 - Light duty applications
 - Low clearance applications
 - Ball or roller bearing applications



MULTI-TURN PLAIN ENDS/MULTI-TURN SHIM ENDS

Light (WSL-MWL) / Medium (WSM-MWM) / Heavy (WSR-MWR)

- Decreasing spring rate is proportional to the number of turns: More turns equals less force.
- Used for low force applications with large deflections.
- Utilizes nearly 1/2 the space as helical compression springs while producing the same force.
- Ideal for:
 - Medium & heavy duty applications
 - High thrust load capacity
 - Light & medium bearing series: double row, tapered bearing depending on the spring version.



CHOOSING A WAVE SPRING:

5 critical factors when considering a wave spring:

- The constraints of the application: Pilot bore/shaft, ID/OD, etc.
- The load (force).
- The working height at which the load is applied.
- The material desired.
- Whether it's dynamic or static.

MATERIAL TYPES:

SAE 1070-1090 CARBON STEEL

- This prehardened material is the standard material for wave springs.
- Less expensive option to Stainless Steel.

(Continued next column)

17-7 STAINLESS STEEL

- Used for high stress and fatigue applications.
- Can withstand much higher temperatures than SAE 1070-1090 and not lose its spring qualities.
- Higher corrosion resistance than SAE 1070-1090.

WAVE SPRING TERMS:

STATIC: A spring that holds a load at a given height for the life of the assembly; there is no cycling of the part.

DYNAMIC: A spring that is constantly moving up and down until the end of its life. It has two working heights and hence, two loads. Generally, the higher the cycle life the stronger the spring needs to be.

HYSTERESIS: The effect in springs where there is a higher response force during compression (loading) and a lower force during relaxation (unloading).

SPRING HEIGHTS: *Free height*—The height of the wave spring when uncompressed; *Work height*—The height the spring is compressed to for delivering the desired force.

OPERATES IN BORE/CLEARNS SHAFT: *Pilot Bore* - Designed to fit in a bore, and have excess clearance by the shaft; *Pilot Shaft* - Designed to fit over a shaft, and have excess clearance by the bore.

LOAD: The force the wave spring exerts when compressed. Load requirements can be stated three ways: A load requirement at a specific working height; the minimum load requirement at one working height, and a maximum load requirement at another working height; the specified spring rate between the minimum and maximum working heights.

SPRING RATE: The force per displacement (lbs./in. or Newton/mm.) More accurate than stamped wave washers.

DEFLECTION: How much the spring compresses.

DIAMETER EXPANSION: A wave spring tends to open outward during compression, which will increase the diameter.

FATIGUE: All springs suffer fatigue, the weakening or failure of a material resulting from prolonged stress. This can be compensated for with optimal materials and sizing.

To have Rotor Clip design engineers help you custom design a wave spring for your particular application, fill out the Custom Wave Spring Design Form available at rotorclip.com/wave_spring_design_form or use our online custom wave spring calculator on rotorclip.com/wsc.



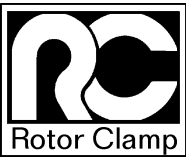

Hose Clamps Self-Compensating

For Low Pressure Applications, Clamp It With Rotor Clamp

Rotor Clamp, Inc. produces a line of self-compensating hose clamps for low-pressure applications in single wire, double wire and constant tension band (CTB) configurations, including light band and narrow band clamps.

Self Compensating Hose Clamps simplify assembly/disassembly, reduce production time and lower costs. Ideal for replacing traditional screw/worm type clamps on low-pressure applications. Clamps also are a good alternative to gluing hoses to manifolds in spa applications, providing extremely effective clamping without the use of messy glues that could potentially clog the hose line.

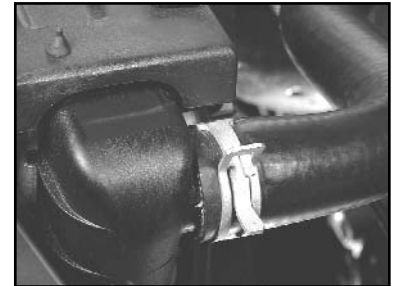

Rotor Clamp Self-Compensating Hose Clamp

- Expands/Contracts with hose in response to temperature changes.
- Cannot be over/under tightened.
- Can be installed automatically eliminating Carpal Tunnel Syndrome (CTS), a nerve disorder of the hand and wrist.
- Less time for assembly lowering production cost.

Competition Screw/Worm Type Clamp

- Must be manually adjusted as temperature changes
- Screw mechanism may be over/under tightened causing damage/leakage to the hose.
- Must be manually installed.
- More time needed for assembly/disassembly due to screw adjustment.



Single Wire
(HC/HW)



Double Wire
(DW)



Constant Tension Band
(CTB)



Constant Tension Light Band
(CTL)

PreOpened, PrePositioned Clamps



This unique, patented version of a preopened clamp is held in the open position by compressing the tangs and allowing the stop to hook on to a complementary notch on the side on one of the tangs.

This clamp is intended solely for rubber hose manufacturers who pre-glue clamps to hoses before supplying to the automotive industry.

A hook catches a "dimple" when the clamp is opened for a more secure hold. The clamp can then be glued in position on a hose.

The mechanism to hold the clamp open is accomplished with only minor changes to the original design of the clamp. The clamp cannot be preopened any further than the stop, ensuring the clamp will not be over-expanded. Contact technical sales for more information: **1-800-557-6867**.

Interchange Chart

Rotor Clip Products May Be Used Interchangeably
With The Part Numbers Indicated Below.

INCH RETAINING RINGS

ROTOR CLIP®	Waldes Truarc®	IRR®	Anderton	Mil Standard
HO	N5000	3000	N1300	16625
HOI	5008	4000	N1308	16627
BHO	N5001	3001	1301	16629
VHO	N5002	-	N1302	16631
SH	5100	3100	N1400	16624
SHI	5108	4100	N1408	16626
SHR	5160	7200	N1460	3217
SHM	5560	-	-	-
BSH	5101	3101	1401	16628
VSH	5102	-	1402	16630
E	5133	1000	N1500	16633
RE	5144	1200	N1540	3215
BE	5131	1001	N1501	16634
C	5103	2000	N1800	16632
PO	5304	-	-	-
POL	T5304	-	-	-
EL	5139	-	-	3216
LC	5107	-	-	90708
SHF	5555	7100	N1440	90707
RG	5135	-	-	-
TX	5115	-	N1465	-
TY	5105	6100	N1405	-
TI	5005	R6000	N1305	-

METRIC RETAINING RINGS

ROTOR CLIP®	Seeger®	Anderton	Ochiai
DHO DIN 472	J	D1300	-
DHI	JV	M1308	-
DHT DIN 984	JK	D2000	-
DHR	JS	D1360	-
DVH	JB	-	-
DSH DIN 471	A	D1400	-
DSI	AV	M1408	-
DST DIN 983	AK	D2100	-
DSR	AS	D1460	-
DVS	-	-	-
DE DIN 6799	RA	D1500	-
DC	H	M1800	-
DTX	ZA	M1465	-
DTI	ZJ	M1305	-
JE (JIS B 2805)	-	-	ETW

SPIRAL RINGS/SHIMS

ROTOR CLIP®	Spirolox®	Smalley®	Mil Standard
KL	UR	VH	-
CL	US	VS	-
KM	RR	WH	MIL-DTL-27426/3
CM	RS	WS	MIL-DTL-27426/1
KR	RRT	WHT	-
CR	RST	WST	-
KG	RRN	WHM	MIL-DTL-27426/4
CG	RSN	WSM	MIL-DTL-27426/2
DKR	-	DNH	-
DCR	-	DNS	-
DKL	-	FH	-
DCL	-	FS	-
KLR	-	FHE	-
CLR	-	FSE	-
MKM	ZRM	-	-
MCM	ZSM	-	-
MKR	ZRT	-	-
MCR	ZST	-	-
MKG	ZRH	-	-
MCG	ZSH	-	-
KLM	-	VHM	-
CLM	-	VSM	-
MKA	-	EH	-
MCA	-	ES	-
NKG	-	WHW	-
NCG	-	WSW	-
KMS	-	SSRS	-

WAVE SPRINGS

ROTOR CLIP®	Spirolox®	Smalley®
SST	TR/TB	SSR
NST	-	SSR Size-N
MST	TR/TB	SSB
WSL	CML	C/CS
WSM	CMM	C/CS
WSR	CMH	C/CS
MWL	-	CM/CMS
MWM	-	CM/CMS
MWR	-	CM/CMS





HO Housing Rings

Axially Assembled, Internal

Once installed in the groove of a housing/bore, the portion of the ring protruding from the groove (also called a "shoulder") holds an assembly in place.

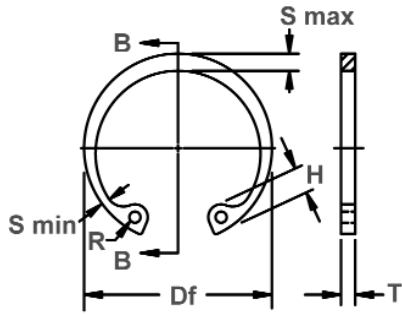

Free Diameter & Ring Measurements with Section B-B

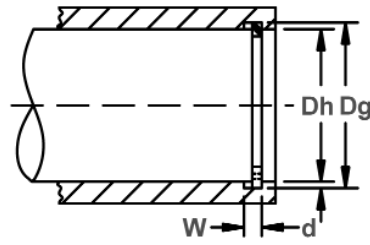

Housing Diameter & Groove Dimensions

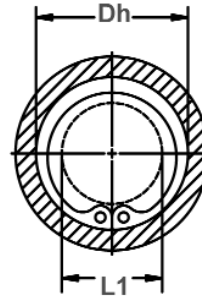

Clearance Diameter Compressed in Housing

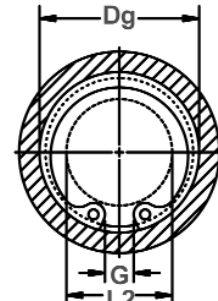

Clearance Diameter & Gap Width Released in Groove

RING NO.	HOUSING DIAMETER			GROOVE SIZE			RING SIZE & WEIGHT				CLEARANCE DIA.			THRUST LD.(lbs.) Sqr. corner abutment			
	Dh DEC	Dh FRAC	Dh mm	DIAMETER		WIDTH		DEPTH	FREE DIAMETER	THICKNESS***	Wght. Per 1000 Pcs.	Compressed in housing	Re-released in groove	Ring Safety Factor of 4	Groove Safety Factor of 2		
				Dg	Tol.	W	Tol.									d	Df
HO-25	.250	1/4	6.4	.268	±.001	.020	+.002	.009	.280		.015		.08	.115	.133	426	190
HO-31	.312	5/16	7.9	.330	.0015*	.020	-.000	.009	.346		.015		.11	.173	.191	538	240
HO-37	.375	3/8	9.5	.397	±.002	.029		.011	.415		.025		.25	.204	.226	1066	350
HO-43	.438	7/16	11.1	.461	.002*	.029		.012	.482		.025		.37	.23	.254	1238	440
HO-45	.453	29/64	11.5	.477		.029		.012	.498		.025		.43	.25	.274	1299	460
HO-50	.500	1/2	12.7	.530		.039		.015	.548	+.010	.035		.70	.26	.290	2010	510
HO-51	.512	-	13.0	.542	±.002	.039		.015	.560	-.005	.035		.77	.27	.300	2060	520
HO-56	.562	9/16	14.3	.596	.004*	.039		.017	.620		.035		.86	.275	.305	2253	710
HO-62	.625	5/8	15.9	.665		.039		.020	.694		.035		1.0	.34	.380	2507	1050
HO-68	.688	11/16	17.5	.732		.039		.022	.763		.035		1.2	.40	.440	2741	1280
HO-75	.750	3/4	19.0	.796		.039	+.003	.023	.831		.035		1.3	.45	.490	3045	1460
HO-77	.777	-	19.7	.825		.046	-.000	.024	.859		.042		1.7	.475	.520	4618	1580
HO-81	.812	13/16	20.6	.862		.046		.025	.901		.042		1.9	.49	.540	4872	1710
HO-86	.866	-	22.0	.920	±.003	.046		.027	.961		.042		2.0	.54	.590	5177	1980
HO-87	.875	7/8	22.2	.931	.004*	.046		.028	.971		.042		2.1	.545	.600	5227	2080
HO-90	.901	-	22.9	.959		.046		.029	1.000	+.015	.042		2.2	.565	.620	5430	2200
HO-93	.938	15/16	23.8	1.000		.046		.031	1.041	-.010	.042	±.002	2.4	.61	.670	5684	2450
HO-100	1.000	1	25.4	1.066		.046		.033	1.111		.042		2.7	.665	.730	6039	2800
HO-102	1.023	-	26.0	1.091		.046		.034	1.136		.042		2.8	.69	.755	6141	3000
HO-106	1.062	1-1/16	27.0	1.130		.056		.034	1.180		.050		3.7	.685	.750	7562	3050
HO-112	1.125	1-1/8	28.6	1.197		.056		.036	1.249		.050		4.0	.745	.815	8019	3400
HO-118	1.181	-	30.0	1.255		.056		.037	1.319		.050		4.3	.79	.860	8526	3700
HO-118	1.188	1-3/16	30.2	1.262	±.004	.056		.037	1.319		.050		4.3	.80	.870	8526	3700
HO-125	1.250	1-1/4	31.7	1.330	.005*	.056		.040	1.388	+.025	.050		4.8	.875	.955	8932	4250
HO-125	1.259	-	32.0	1.339		.056		.040	1.388	-.020	.050		4.8	.885	.965	8932	4250
HO-131	1.312	1-5/16	33.3	1.396		.056		.042	1.456		.050		5.0	.93	1.01	9440	4700
HO-137	1.375	1-3/8	34.9	1.461		.056		.043	1.526		.050		5.1	.99	1.07	9846	5050
HO-137	1.378	-	35.0	1.464		.056	+.004	.043	1.526		.050		5.1	.99	1.07	9846	5050
HO-143	1.438	1-7/16	36.5	1.528		.056	-.000	.045	1.596		.050		5.8	1.06	1.15	10353	5500
HO-145	1.456	-	37.0	1.548		.056		.046	1.616		.050		6.4	1.08	1.17	10455	5700
HO-150	1.500	1-1/2	38.1	1.594		.056		.047	1.660		.050		6.5	1.12	1.21	10708	6000
HO-156	1.562	1-9/16	39.7	1.658		.068		.048	1.734		.062		8.9	1.14	1.23	13906	6350
HO-156	1.575	-	40.0	1.671		.068		.048	1.734		.062		8.9	1.15	1.24	13906	6350
HO-162	1.625	1-5/8	41.3	1.725	±.005	.068		.050	1.804	+.035	.062		10.0	1.15	1.25	14413	6900
HO-165	1.653	-	42.0	1.755	.005*	.068		.051	1.835	-.025	.062	±.003	10.4	1.17	1.27	14718	7200
HO-168	1.688	1-11/16	42.9	1.792		.068		.052	1.874		.062		10.8	1.23	1.33	15022	7450
HO-175	1.750	1-3/4	44.4	1.858		.068		.054	1.942		.062		10.3	1.26	1.36	15580	8050
HO-181	1.812	1-13/16	46.0	1.922		.068		.055	2.012		.062		11.5	1.34	1.38	16139	8450

* F.I.M. (FULL INDICATOR MOVEMENT)- MAXIMUM ALLOWABLE DEVIATION OF CONCENTRICITY BETWEEN GROOVE & HOUSING.

† BASED ON HOUSINGS/SHAFTS MADE OF COLD ROLLED STEEL. FOR AN EXPLANATION OF FORMULAS USED TO DERIVE THRUST LOAD AND OTHER PERFORMANCE DATA CONTACT THE ROTOR CLIP ENGINEERING DEPARTMENT.

***FOR PLATED RINGS ADD .002" TO THE LISTED MAXIMUM THICKNESS. MAXIMUM THICKNESS WILL BE A MINIMUM OF .0002" LESS THAN THE LISTED GROOVE WIDTH (W) MINIMUM.

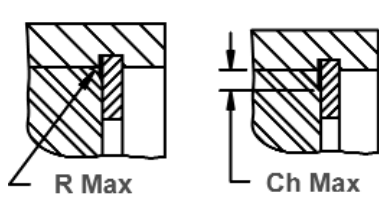

Allowable Corner Radius and Chamfer

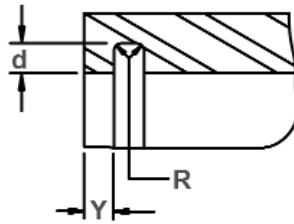

Exploded Groove Profile & Edge Margin (Y)
Maximum bottom radii (R), .005 for ring sizes
-25 thru -100; .010 for ring sizes 102 thru 1000

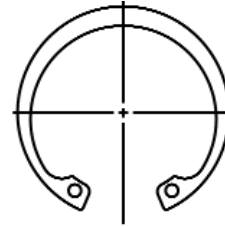

Alternate Lug Design
For Larger Sizes
(Manufacturer's Option)

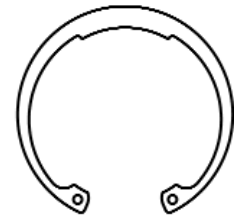

Alternate Design
(Manufacturer's Option)

RING NO.	LUG HEIGHT		MAXIMUM SECTION		MINIMUM SECTION		HOLE DIAMETER		GAP WIDTH Ring in Groove	ALLOWABLE CORNER RADII & CHAMFERS			MAX. LOAD w/ R max or Ch max (lbs.)	EDGE MARGIN Y
	H	Tol.	S max	Tol.	S min	Tol.	R	Tol.		G Min	R max	Ch max		
HO-25	.065		.025	±.002	.015	±.002	.031		.047	.011	.0085	190	.027	
HO-31	.066		.033		.018		.031		.055	.016	.013	190	.027	
HO-37	.082	±.003	.040		.028		.041		.063	.023	.018	530	.033	
HO-43	.098		.049	±.003	.029	±.003	.041		.063	.027	.021	530	.036	
HO-45	.098		.050		.030		.047		.071	.027	.021	530	.036	
HO-50	.114		.053		.035		.047		.090	.027	.021	1100	.045	
HO-51	.114		.053		.035		.047		.092	.027	.021	1100	.045	
HO-56	.132		.053	±.004	.035	±.004	.047	+ .010	.095	.027	.021	1100	.051	
HO-62	.132		.060		.035		.062	- .002	.104	.027	.021	1100	.060	
HO-68	.132		.063		.036		.062		.118	.027	.021	1100	.066	
HO-75	.142		.070		.040		.062		.143	.032	.025	1100	.069	
HO-77	.146		.074		.044		.062		.145	.035	.028	1650	.072	
HO-81	.155		.077		.044		.062		.153	.035	.028	1650	.075	
HO-86	.155		.081		.045		.062		.172	.035	.028	1650	.081	
HO-87	.155		.084		.045		.062		.179	.035	.028	1650	.084	
HO-90	.155		.087	±.005	.047	±.005	.062		.188	.038	.030	1650	.087	
HO-93	.155		.091		.050		.062		.200	.038	.030	1650	.093	
HO-100	.155		.104		.052		.062		.212	.042	.034	1650	.099	
HO-102	.155	±.005	.106		.054		.062		.220	.042	.034	1650	.102	
HO-106	.180		.110		.055		.078		.213	.044	.035	2400	.102	
HO-112	.180		.116		.057		.078		.232	.047	.036	2400	.108	
HO-118	.180		.120		.058		.078		.226	.047	.036	2400	.111	
HO-118	.180		.120		.058		.078		.245	.047	.036	2400	.111	
HO-125	.180		.124		.062		.078		.265	.048	.038	2400	.120	
HO-125	.180		.124	±.006	.062	±.006	.078		.290	.048	.038	2400	.120	
HO-131	.180		.130		.062		.078		.284	.048	.038	2400	.126	
HO-137	.180		.130		.063		.078	+ .015	.297	.048	.038	2400	.129	
HO-137	.180		.130		.063		.078	- .002	.305	.048	.038	2400	.129	
HO-143	.180		.133		.065		.078		.313	.048	.038	2400	.135	
HO-145	.180		.133		.065		.078		.320	.048	.038	2400	.138	
HO-150	.180		.133		.066		.078		.340	.048	.038	2400	.141	
HO-156	.202		.157		.078		.078		.338	.064	.050	3900	.144	
HO-156	.202		.157		.078		.078		.374	.064	.050	3900	.144	
HO-162	.227		.164		.082		.078		.339	.064	.050	3900	.150	
HO-165	.230		.167	±.007	.083	±.007	.078		.348	.064	.050	3900	.153	
HO-168	.230		.170		.085		.078		.357	.064	.050	3900	.156	
HO-175	.230		.170		.083		.078		.372	.064	.050	3900	.162	
HO-181	.230		.170		.084		.093		.382	.064	.050	3900	.165	

FOR HARDNESS SPECIFICATIONS, SEE END OF THIS SECTION



HO Housing Rings

Axially Assembled, Internal

Once installed in the groove of a housing/bore, the portion of the ring protruding from the groove (also called a "shoulder") holds an assembly in place.

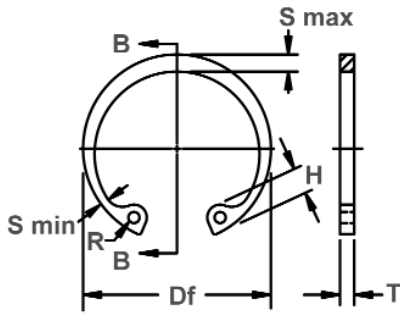

Free Diameter & Ring Measurements with Section B-B

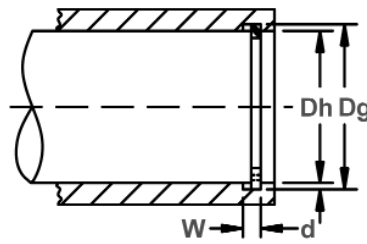

Housing Diameter & Groove Dimensions

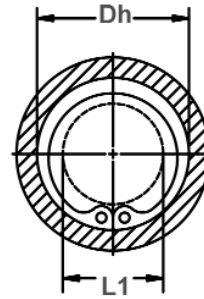

Clearance Diameter Compressed in Housing

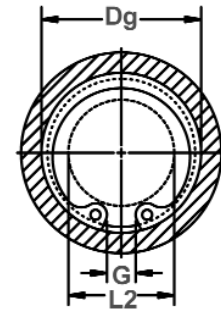

Clearance Diameter & Gap Width Released in Groove

RING NO.	HOUSING DIAMETER			GROOVE SIZE			RING SIZE & WEIGHT				CLEARANCE DIA.			i THRUST LD. (lbs.)			
				DIAMETER		WIDTH	DEPTH	Free Diameter		Thickness***		Wght. Per 1000 Pcs.	Compressed in housing	Re-leased in groove	Sqr. corner abutment		
	Dh DEC	Dh FRAC	Dh mm	Dg	Tol.	W	Tol.	d	Df	Tol.	T				Tol.	L1	L2
HO-185	1.850	-	47.0	1.962		.068		.056	2.054		.062		12.8	1.35	1.46	16443	8750
HO-187	1.875	1-7/8	47.6	1.989	±.005	.068	+.004	.057	2.072	+.035	.062		12.8	1.37	1.48	16697	9050
HO-193	1.938	1-15/16	49.2	2.056	.005*	.068	-.000	.059	2.141	-.025	.062		13.3	1.46	1.58	17255	9700
HO-200	2.000	2	50.8	2.122		.068		.061	2.210		.062		14.0	1.52	1.64	17763	10300
HO-206	2.047	-	52.0	2.171		.086		.062	2.280		.078		18.0	1.52	1.64	23091	10850
HO-206	2.062	2-1/16	52.4	2.186		.086		.062	2.280		.078		18.0	1.54	1.66	23091	10850
HO-212	2.125	2-1/8	54.0	2.251		.086		.063	2.350		.078		19.4	1.58	1.70	23751	11350
HO-218	2.165	-	55.0	2.295		.086		.065	2.415		.078		19.6	1.63	1.75	24461	12050
HO-218	2.188	2-3/16	55.6	2.318		.086		.065	2.415		.078		19.6	1.66	1.79	24461	12050
HO-225	2.250	2-1/4	57.1	2.382		.086		.066	2.490		.078		21.8	1.67	1.80	25223	12600
HO-231	2.312	2-5/16	58.7	2.450		.086		.069	2.560		.078		22.6	1.73	1.93	25832	13550
HO-237	2.375	2-3/8	60.3	2.517		.086		.071	2.630		.078		23.2	1.79	1.86	26542	14300
HO-244	2.440	2-7/16	62.0	2.584		.086		.072	2.702	+.040	.078		25.4	1.86	2.00	27304	14900
HO-250	2.500	2-1/2	63.5	2.648		.086		.074	2.775	-.030	.078		25.5	1.91	2.05	28014	15650
HO-250	2.531	2-17/32	64.3	2.681		.086		.075	2.775		.078		25.5	1.94	2.09	28014	15650
HO-256	2.562	2-9/16	65.1	2.714		.103		.076	2.844		.093		34.0	1.93	2.08	34206	16500
HO-262	2.625	2-5/8	66.7	2.781	±.006	.103	+.005	.078	2.910		.093	±.003	34.5	2.02	2.17	35068	17350
HO-268	2.677	-	68.0	2.837	.006*	.103	-.000	.080	2.980		.093		35.0	2.05	2.21	35931	18250
HO-268	2.688	2-11/16	68.3	2.848		.103		.080	2.980		.093		35.0	2.06	2.22	35931	18250
HO-275	2.750	2-3/4	69.8	2.914		.103		.082	3.050		.093		35.5	2.12	2.28	36642	19200
HO-281	2.812	2-13/16	71.4	2.980		.103		.084	3.121		.093		36.0	2.18	2.34	37504	20050
HO-281	2.835	-	72.0	3.006		.103		.085	3.121		.093		36.0	2.21	2.38	37504	20050
HO-287	2.875	2-7/8	73.0	3.051		.103		.088	3.191		.093		41.0	2.24	2.41	38367	21500
HO-300	2.953	-	75.0	3.135		.103		.091	3.325		.093		42.5	2.32	2.50	40093	23150
HO-300	3.000	3	76.2	3.182		.103		.091	3.325		.093		42.5	2.37	2.55	40093	23150
HO-306	3.062	3-1/16	77.8	3.248		.120		.093	3.418		.109		53.0	2.41	2.59	47807	24100
HO-312	3.125	3-1/8	79.4	3.315		.120		.095	3.488		.109		56.0	2.47	2.66	48822	25200
HO-315	3.149	-	80.0	3.341		.120		.096	3.523		.109		57.0	2.49	2.68	49329	25700
HO-315	3.156	3-5/32	80.2	3.348		.120		.096	3.523		.109		57.0	2.50	2.69	49329	25700
HO-325	3.250	3-1/4	82.5	3.446		.120		.098	3.623	±.055	.109		60.0	2.54	2.73	50750	27000
HO-334	3.346	3-11/32	85.0	3.546		.120		.100	3.734		.109		65.0	2.63	2.83	52374	28300
HO-347	3.469	3-15/32	88.1	3.675		.120		.103	3.857		.109		69.0	2.76	2.96	54201	30200
HO-350	3.500	3-1/2	88.9	3.710		.120		.105	3.890		.109		71.0	2.79	3.00	54709	31200
HO-354	3.543	-	90.0	3.755		.120		.106	3.936		.109		72.0	2.83	3.04	55419	31800
HO-354	3.562	3-9/16	90.5	3.776		.120		.107	3.936		.109		72.0	2.85	3.06	55419	31800
HO-362	3.625	3-5/8	92.1	3.841		.120		.108	4.024		.109		73.0	2.91	3.12	56739	33200
HO-375	3.740	-	95.0	3.964		.120		.112	4.157	±.065	.109		78.0	3.02	3.24	58566	35600
HO-375	3.750	3-3/4	95.2	3.974		.120		.112	4.157		.109		78.0	3.03	3.25	58566	35600

* F.I.M. (FULL INDICATOR MOVEMENT)- MAXIMUM ALLOWABLE DEVIATION OF CONCENTRICITY BETWEEN GROOVE & HOUSING.

i BASED ON HOUSINGS/SHAFTS MADE OF COLD ROLLED STEEL. FOR AN EXPLANATION OF FORMULAS USED TO DERIVE THRUST LOAD AND OTHER PERFORMANCE DATA CONTACT THE ROTOR CLIP ENGINEERING DEPARTMENT.

***FOR PLATED RINGS ADD .002" TO THE LISTED MAXIMUM THICKNESS. MAXIMUM THICKNESS WILL BE A MINIMUM OF .0002" LESS THAN THE LISTED GROOVE WIDTH (W) MINIMUM.

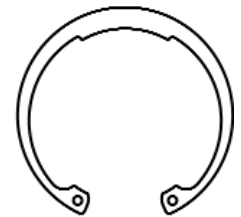
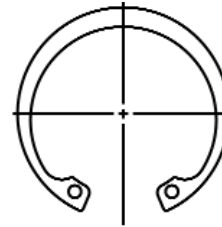
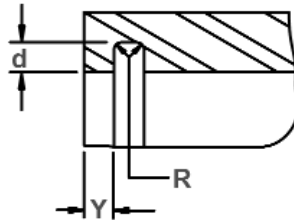
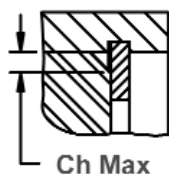
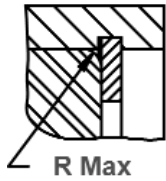

Allowable Corner Radius and Chamfer

Exploded Groove Profile & Edge Margin (Y)
Maximum bottom radii (R), .005 for ring sizes
-25 thru -100; .010 for ring sizes 102 thru 1000

Alternate Lug Design
For Larger Sizes
(Manufacturer's Option)

Alternate Design
(Manufacturer's Option)

RING NO.	LUG HEIGHT		MAXIMUM SECTION		MINIMUM SECTION		HOLE DIAMETER		GAP WIDTH Ring in Groove	ALLOWABLE CORNER RADII & CHAMFERS			MAX. LOAD w/ R max or Ch max (lbs.)	EDGE MARGIN
	H	Tol.	S max	Tol.	S min	Tol.	R	Tol.		G Min	R max	Ch max		
HO-185	.234		.170		.085		.093		.360	.064	.050	3900	.168	
HO-187	.234		.170		.085		.093		.430	.064	.050	3900	.171	
HO-193	.230		.170		.085		.093		.438	.064	.050	3900	.177	
HO-200	.230		.170		.085		.093		.453	.064	.050	3900	.183	
HO-206	.250		.186		.091		.093		.428	.078	.061	6200	.186	
HO-206	.250		.186		.091		.093		.468	.078	.062	6200	.186	
HO-212	.250		.195		.096		.093		.460	.078	.062	6200	.189	
HO-218	.250		.199		.098		.093		.439	.078	.062	6200	.195	
HO-218	.250		.199		.098		.093		.489	.078	.062	6200	.195	
HO-225	.280		.203		.099		.093		.478	.078	.062	6200	.198	
HO-231	.280	±.005	.206	±.007	.100	±.007	.093		.486	.078	.062	6200	.207	
HO-237	.280		.207		.102		.093		.504	.078	.062	6200	.213	
HO-244	.280		.209		.103		.110		.518	.078	.062	6200	.216	
HO-250	.280		.210		.103		.110		.532	.078	.062	6200	.222	
HO-250	.280		.210		.103		.110	+ .015	.597	.078	.062	6200	.225	
HO-256	.300		.222		.109		.110	- .002	.540	.088	.070	9000	.228	
HO-262	.290		.226		.111		.110		.558	.088	.070	9000	.234	
HO-268	.300		.230		.113		.110		.539	.090	.072	9000	.240	
HO-268	.300		.230		.113		.110		.568	.090	.072	9000	.240	
HO-275	.300		.234		.115		.110		.590	.092	.074	9000	.246	
HO-281	.300		.230		.115		.110		.615	.088	.070	9000	.252	
HO-281	.300		.230		.115		.110		.676	.088	.070	9000	.255	
HO-287	.300		.240		.120		.110		.626	.092	.074	9000	.264	
HO-300	.300		.250		.122		.110		.619	.092	.074	9000	.273	
HO-300	.300		.250		.122		.110		.738	.092	.074	9000	.273	
HO-306	.310		.254		.126		.125		.651	.097	.078	12000	.279	
HO-312	.310		.259		.129		.125		.655	.099	.079	12000	.285	
HO-315	.310		.262		.129		.125		.650	.100	.080	12000	.288	
HO-315	.310		.262		.129		.125		.669	.100	.080	12000	.288	
HO-325	.342		.269		.135		.125		.698	.104	.083	12000	.294	
HO-334	.342	±.008	.276	±.008	.140	±.008	.125		.705	.108	.086	12000	.300	
HO-347	.342		.286		.144		.125		.763	.108	.086	12000	.309	
HO-350	.342		.289		.142		.125		.774	.110	.088	12000	.315	
HO-354	.342		.292		.142		.125		.788	.110	.088	12000	.318	
HO-354	.342		.292		.142		.125		.842	.110	.088	12000	.321	
HO-362	.342		.299		.150		.125		.833	.116	.093	12000	.324	
HO-375	.342		.309		.155		.125		.844	.120	.096	12000	.336	
HO-375	.342		.309		.155		.125		.871	.120	.096	12000	.336	

FOR HARDNESS SPECIFICATIONS, SEE END OF THIS SECTION



HO Housing Rings

Axially Assembled, Internal

Once installed in the groove of a housing/bore, the portion of the ring protruding from the groove (also called a "shoulder") holds an assembly in place.

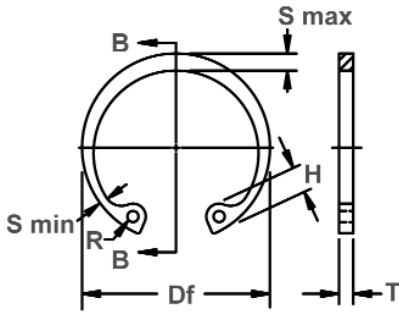

Free Diameter & Ring Measurements with Section B-B

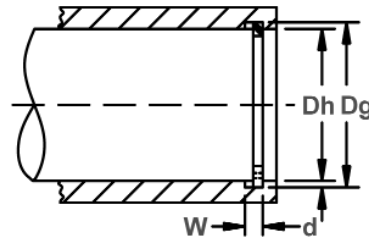

Housing Diameter & Groove Dimensions

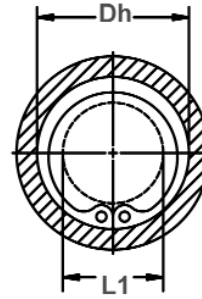

Clearance Diameter Compressed in Housing

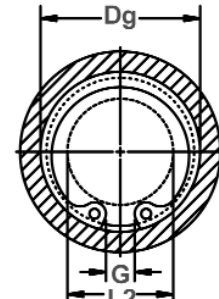

Clearance Diameter & Gap Width Released in Groove

RING NO.	HOUSING DIAMETER			GROOVE SIZE			RING SIZE & WEIGHT				CLEAR. DIA.			† THRUST LD. (lbs.)			
				DIAMETER		WIDTH	DEPTH	Free Diameter		Thickness***		Weight. Per 1000 Pcs.	Compressed in housing	Released in groove	Sqr. corner abutment	Ring Safety Factor of 4	Groove Safety Factor of 2
	Dh DEC	Dh FRAC	Dh mm	Dg	Tol.	W	Tol.	d	Df	Tol.	T						
HO-387	3.875	3-7/8	98.4	4.107		.120		.116	4.291		.109		87.0	3.11	3.34	60494	38000
HO-393	3.938	3-15/16	100.0	4.174		.120		.118	4.358		.109		88.0	3.17	3.40	61611	39300
HO-400	4.000	4	101.6	4.240		.120		.120	4.424		.109		93.0	3.23	3.47	62626	40700
HO-412	4.125	4-1/8	104.8	4.365		.120		.120	4.558		.109		97.0	3.36	3.60	64554	42000
HO-425	4.250	4-1/4	108.0	4.490	±.006	.120	+ .005	.120	4.691		.109	±.003	101.0	3.48	3.72	66483	43200
HO-433	4.331	-	110.0	4.571	.006*	.120	-.000	.120	4.756		.109		105.0	3.50	3.74	67599	44500
HO-450	4.500	4-1/2	114.3	4.740		.120		.120	4.940		.109		111.0	3.66	3.90	70340	45800
HO-462	4.625	4-5/8	117.5	4.865		.120		.120	5.076	±.065	.109		117.0	3.79	4.03	72370	47000
HO-475	4.724	-	120.0	4.969		.120		.122	5.213		.109		124.0	3.88	4.12	74298	49000
HO-475	4.750	4-3/4	120.6	4.995		.120		.122	5.213		.109		124.0	3.90	4.14	74298	49000
HO-500	5.000	5	127.0	5.260		.120		.130	5.485		.109		136.0	4.08	4.34	78155	55000
HO-525	5.250	5-1/4	133.3	5.520		.139		.135	5.770		.125		174.0	4.35	4.62	94091	60000
HO-537	5.375	5-3/8	136.5	5.650	±.007	.139	+ .006	.135	5.910		.125		179.0	4.45	4.72	96324	61500
HO-550	5.500	5-1/2	139.7	5.770	.006*	.139	-.000	.135	6.066		.125	±.004	183.0	4.57	4.84	98658	63300
HO-575	5.750	5-3/4	146.0	6.020		.139		.135	6.336		.125		192.0	4.82	5.09	103124	65900
HO-600	6.000	6	152.4	6.270		.139		.135	6.620		.125		202.1	5.07	5.34	107489	68600
HO-625	6.250	6-1/4	158.7	6.530		.174		.140	6.895		.156		266.0	5.24	5.52	139766	74100
HO-650	6.500	6-1/2	165.1	6.790		.174		.145	7.170		.156		281.0	5.49	5.78	145450	79900
HO-662	6.625	6-5/8	168.3	6.925		.174		.150	7.308	±.080	.156		305.0	5.60	5.90	148190	84200
HO-675	6.750	6-3/4	171.4	7.055		.174		.152	7.445		.156		325.0	5.68	5.98	151032	87000
HO-700	7.000	7	177.8	7.315		.174		.157	7.720		.156		344.0	5.91	6.22	156615	93100
HO-725	7.250	7-1/4	184.1	7.575		.209		.162	7.995		.187		428.0	6.11	6.43	194373	99600
HO-750	7.500	7-1/2	190.5	7.840	±.008	.209	+ .008	.170	8.270		.187		485.0	6.36	6.70	201173	108100
HO-775	7.750	7-3/4	196.8	8.100	.006*	.209	-.000	.175	8.545		.187		520.0	6.58	6.93	207872	115000
HO-800	8.000	8	203.2	8.360		.209		.180	8.820		.187	±.005	555.0	6.83	7.19	214571	122000
HO-825	8.250	8-1/4	209.5	8.620		.209		.185	9.095		.187		603.0	7.04	7.41	221270	129300
HO-850	8.500	8-1/2	215.9	8.880		.209		.190	9.285	±.090	.187		634.0	7.29	7.67	227969	136900
HO-875	8.750	8-3/4	222.2	9.145		.209		.197	9.558		.187		653.0	7.38	7.77	233856	145500
HO-900	9.000	9	228.6	9.405		.209		.202	9.830		.187		732.0	7.63	8.03	241367	154100
HO-925	9.250	9-1/4	235.0	9.668		.209		.209	10.102		.187		767.0	7.88	8.30	248066	163600
HO-950	9.500	9-1/2	241.3	9.930		.209		.215	10.375		.187		803.0	7.98	8.41	254765	173100
HO-975	9.750	9-3/4	247.7	10.190		.209		.220	10.648		.187		833.0	8.23	8.67	261464	181900
HO-1000	10.000	10	254.0	10.450		.209		.225	10.920		.187		863.0	8.48	8.93	268163	190700

* F.I.M. (FULL INDICATOR MOVEMENT)- MAXIMUM ALLOWABLE DEVIATION OF CONCENTRICITY BETWEEN GROOVE & HOUSING.

† BASED ON HOUSINGS/SHAFTS MADE OF COLD ROLLED STEEL. FOR AN EXPLANATION OF FORMULAS USED TO DERIVE THRUST LOAD AND OTHER PERFORMANCE DATA CONTACT THE ROTOR CLIP ENGINEERING DEPARTMENT.

***FOR PLATED RINGS ADD .002" TO THE LISTED MAXIMUM THICKNESS. MAXIMUM THICKNESS WILL BE A MINIMUM OF .0002" LESS THAN THE LISTED GROOVE WIDTH (W) MINIMUM.

HARDNESS RANGES: STAINLESS STEEL RINGS (PH 15-7MO)

RING TYPE	SIZE RANGE	SCALE	ROCKWELL HARDNESS
HO	25&31	15N	82.5-86
	37-102	30N	63-69.5
	106+	C	44-51

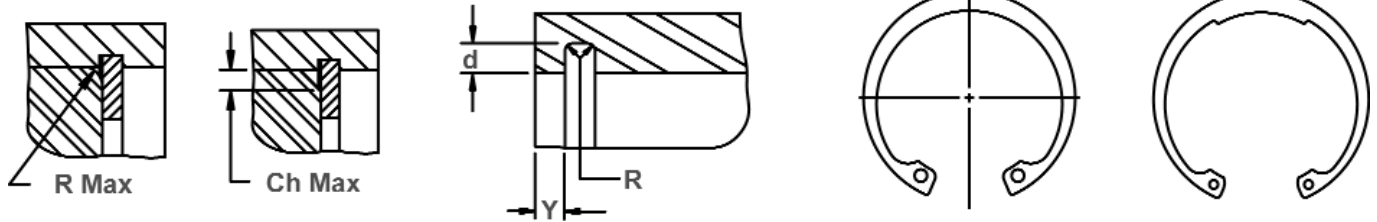

Allowable Corner Radius and Chamfer

Exploded Groove Profile & Edge Margin (Y)
Maximum bottom radii (R), .005 for ring sizes
-25 thru -100; .010 for ring sizes 102 thru 1000

Alternate Lug Design
For Larger Sizes
(Manufacturer's Option)

Alternate Design
(Manufacturer's Option)

RING NO.	LUG HEIGHT		MAXIMUM SECTION		MINIMUM SECTION		HOLE DIAMETER		GAP WIDTH Ring in Groove	EDGE MARGIN	ALLOWABLE CORNER RADII & CHAMFERS		MAX. LOAD w/R max or Ch max. (lbs.)
	H	Tol.	S max	Tol.	S min	Tol.	R	Tol.			G Min	Y	
HO-387	.370		.319		.160		.125		.891	.348	.123	.098	12000
HO-393	.370		.324	±.008	.161	±.008	.125	+.015	.905	.354	.124	.099	12000
HO-400	.370		.330		.166		.125	-.002	.918	.360	.128	.102	12000
HO-412	.370		.330		.171		.125		.940	.360	.130	.104	12000
HO-425	.370		.335		.180		.125		.960	.360	.138	.110	12000
HO-433	.405	±.008	.343		.180		.156		1.000	.360	.142	.114	12000
HO-450	.405		.351		.181		.156		.980	.360	.146	.117	12000
HO-462	.405		.405		.183		.156		1.000	.360	.151	.121	12000
HO-475	.405		.370		.183		.156		.960	.366	.154	.123	12000
HO-475	.405		.370	±.009	.183	±.009	.156		1.030	.366	.154	.123	12000
HO-500	.435		.390		.186		.156		.970	.390	.158	.126	12000
HO-525	.435		.435		.198		.156		1.10	.405	.168	.134	15000
HO-537	.455		.408		.198		.156		1.12	.405	.168	.134	15000
HO-550	.435		.435		.198		.156		1.09	.405	.168	.134	15000
HO-575	.435		.435		.198		.156		1.11	.405	.168	.134	15000
HO-600	.435		.435		.198		.156		1.13	.405	.168	.134	15000
HO-625	.485		.485		.211		.187	+.020	1.16	.420	.177	.142	23000
HO-650	.485		.438		.219		.187	-.005	1.25	.435	.181	.145	23000
HO-662	.485		.485		.221		.187		1.28	.450	.183	.146	23000
HO-675	.530		.456		.224		.187		1.21	.456	.188	.150	23000
HO-700	.515		.515		.232		.187		1.26	.471	.196	.157	23000
HO-725	.545	±.010	.545		.238		.187		1.32	.486	.202	.162	34000
HO-750	.560		.507		.247		.187		1.39	.510	.208	.166	34000
HO-775	.560		.523		.255		.187		1.44	.525	.214	.171	34000
HO-800	.560		.560		.262		.187		1.50	.540	.220	.176	34000
HO-825	.600		.558	±.010	.270	±.010	.187		1.53	.555	.229	.183	34000
HO-850	.660		.573		.277		.187		1.71	.570	.235	.188	34000
HO-875	.660		.591		.286		.187		1.77	.591	.241	.193	34000
HO-900	.660		.609		.294		.187		1.83	.606	.249	.199	34000
HO-925	.660		.625		.299		.187		1.87	.627	.253	.202	34000
HO-950	.735		.642		.304		.187		1.91	.645	.258	.206	34000
HO-975	.735		.658		.309		.187		2.00	.660	.263	.210	34000
HO-1000	.735		.675		.315		.187		2.01	.675	.270	.216	34000

LARGER SIZES MAY BE AVAILABLE UPON REQUEST.

HARDNESS RANGES: CARBON STEEL RINGS (SAE 1060-1090)

RING TYPE	SIZE RANGE	SCALE	ROCKWELL HARDNESS
HO	25&31	15N	86-88
	37-51	30N	69.5-73
	56-77	30N	67.5-72
	81-102	30N	66-71
	106-347	C	47-52
	350-700	C	44-51
	725-1000	C	40-47

HARDNESS RANGES: BERYLLIUM COPPER RINGS

RING TYPE	SIZE RANGE	SCALE	ROCKWELL HARDNESS
HO	25&31	15N	77-82
	37-102	30N	54-62
	106+	C	34-43





SH Shaft Rings

Axially Assembled, External

Once installed in the groove of a shaft, the portion of the ring protruding from the groove (also called a "shoulder") holds an assembly in place.

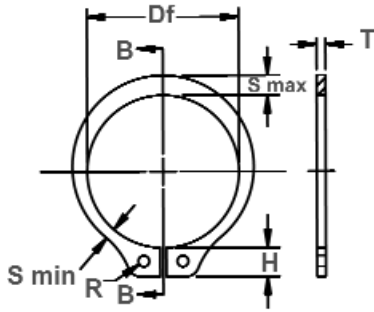

Free Diameter & Ring Measurements with Section B-B

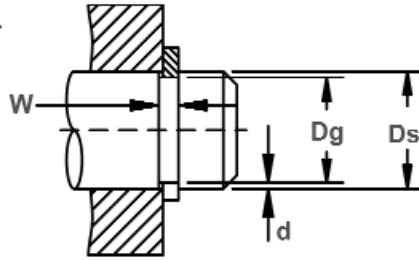

Shaft Diameter & Groove Dimensions

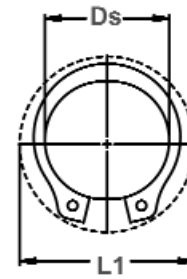

Clearance Diameter Expanded Over Shaft

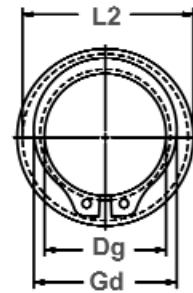

Clearance Diameter & Gaging Diameter Released in Groove.

RING NO.	SHAFT DIAMETER			GROOVE SIZE			RING SIZE & WEIGHT				CLEARANCE DIA.			THRUST LD. (lbs.)			
				DIAMETER		WIDTH	DEPTH	FREE DIAMETER		THICKNESS***	Weight Per 1000 pcs.	Expanded over Shaft	Re-leased in Groove	Sqr. Corner Abutment			
	Ds DEC	Ds FRAC	Ds mm	Dg	Tol.	W	Tol.	d	Df	Tol.				T	Tol.	L1	L2
**SH-12	.125	1/8	3.2	.117		.012		.004	.112		.010	±.001	.018	.222	.214	112	35
**SH-15	.156	5/32	4.0	.146		.012		.005	.142		.010		.037	.27	.260	132	55
**SH-18	.188	3/16	4.8	.175	±.0015	.018	+.002	.006	.168	+.002	.015		.059	.298	.286	244	80
**SH-19	.197	-	5.0	.185	.0015*	.018	-.000	.006	.179	-.004	.015		.063	.319	.307	254	85
**SH-21	.219	7/32	5.6	.205		.018		.007	.196		.015		.074	.338	.324	284	110
**SH-23	.236	15/64	6.0	.222		.018		.007	.215		.015		.086	.355	.341	315	120
SH-25	.250	1/4	6.4	.230		.029		.010	.225		.025		.21	.45	.43	599	175
SH-27	.276	-	7.0	.255		.029		.010	.250		.025		.23	.48	.46	660	195
SH-28	.281	9/32	7.1	.261		.029		.010	.256		.025		.24	.49	.47	670	200
SH-31	.312	5/16	7.9	.290		.029		.011	.281		.025		.27	.54	.52	751	240
SH-34	.344	11/32	8.7	.321	±.002	.029		.011	.309		.025		.31	.57	.55	812	265
SH-35	.354	-	9.0	.330	.002*	.029		.012	.320	+.002	.025		.35	.59	.57	832	300
SH-37	.375	3/8	9.5	.352		.029		.012	.338	-.005	.025		.39	.61	.59	883	320
SH-39	.394	-	10.0	.369		.029		.012	.354		.025		.42	.62	.60	954	335
SH-40	.406	13/32	10.3	.382		.029		.012	.366		.025		.43	.63	.61	964	350
SH-43	.438	7/16	11.1	.412		.029		.013	.395		.025		.50	.66	.64	1035	400
SH-46SP1	.461	-	11.7	.435		.029		.013	.420		.025		.51	.68	.66	1110	460
SH-46	.469	15/32	11.9	.443		.029		.013	.428		.025	±.002	.54	.68	.66	1117	450
SH-50	.500	1/2	12.7	.468	±.002	.039	+.003	.016	.461		.035		.91	.77	.74	1675	550
SH-55	.551	-	14.0	.519	.004*	.039	-.000	.016	.509		.035		.90	.81	.78	1800	600
SH-56	.562	9/16	14.3	.530		.039		.016	.521		.035		1.1	.82	.79	1878	650
SH-59	.594	19/32	15.1	.559		.039		.017	.550		.035		1.2	.86	.83	1979	750
SH-62	.625	5/8	15.9	.588		.039		.018	.579		.035		1.3	.90	.87	2091	800
SH-66	.669	-	17.0	.629		.039		.020	.621	+.005	.035		1.4	.93	.89	2233	950
SH-66	.672	43/64	17.1	.631		.039		.020	.621	-.010	.035		1.4	.93	.89	2233	950
SH-68	.688	11/16	17.5	.646		.046		.021	.635		.042		1.8	1.01	.97	3451	1000
SH-75	.750	3/4	19.0	.704	±.003	.046		.023	.693		.042		2.1	1.09	1.05	3756	1200
SH-78	.781	25/32	19.8	.733	.004*	.046		.024	.722		.042		2.2	1.12	1.08	3959	1300
SH-81	.812	13/16	20.6	.762		.046		.025	.751		.042		2.5	1.15	1.10	4060	1450
SH-84	.844	-	21.4	.791		.046		.026	.780		.042		2.7	1.18	1.13	4200	1500
SH-87	.875	7/8	22.2	.821		.046		.027	.810		.042		2.8	1.21	1.16	4365	1650
SH-93	.938	15/16	23.8	.882		.046		.028	.867		.042		3.1	1.34	1.29	4720	1850
SH-98	.984	63/64	25.0	.926		.046		.029	.910		.042		3.5	1.39	1.34	4923	2000
SH-100	1.000	1	25.4	.940		.046		.030	.925		.042		3.6	1.41	1.35	5024	2100
SH-102	1.023	-	26.0	.961		.046		.031	.946		.042		3.9	1.43	1.37	5126	2250
SH-106	1.062	1-1/16	27.0	.998	±.004	.056	+.004	.032	.982	+.010	.050		4.8	1.50	1.44	6293	2400
SH-112	1.125	1-1/8	28.6	1.059	.005*	.056	-.000	.033	1.041	-.015	.050		5.1	1.55	1.49	6699	2600

**SIZES -12 THRU -23 STANDARD MATERIAL- CARBON STEEL; OPTIONAL MATERIAL- BERYLLIUM COPPER.

* F.I.M. (FULL INDICATOR MOVEMENT)- MAXIMUM ALLOWABLE DEVIATION OF CONCENTRICITY BETWEEN GROOVE & SHAFT.

† BASED ON HOUSINGS/SHAFTS MADE OF COLD ROLLED STEEL. FOR AN EXPLANATION OF FORMULAS USED TO DERIVE THRUST LOAD AND OTHER PERFORMANCE DATA CONTACT THE ROTOR CLIP ENGINEERING DEPARTMENT.

***FOR PLATED RINGS ADD .002" TO THE LISTED MAXIMUM THICKNESS. MAXIMUM THICKNESS WILL BE A MINIMUM OF .0002" LESS THAN THE LISTED GROOVE WIDTH (W) MINIMUM.



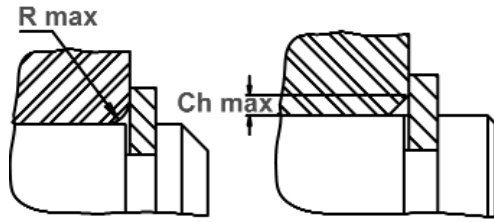

Maximum Corner Radius & Chamfer

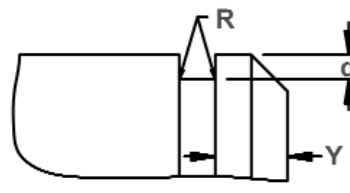

Exploded Groove Profile & Edge Margin (Y)
Maximum bottom radii (R), sharp corners for ring sizes -12 thru -23; .003 for ring sizes -25 thru -35; .005 for sizes -37 thru -100; .010 for ring sizes -102 thru -1000

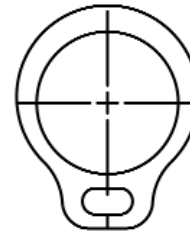

Lug Design For Sizes SH-12 thru SH-23

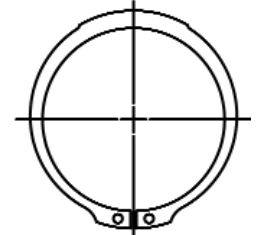

Alternate Design Manufacturer's Option

RING NO.	LUG HEIGHT		MAXIMUM SECTION		MINIMUM SECTION		HOLE DIAMETER		GAGING DIA.	ALLOWABLE CORNER RADII & CHAMFERS			MAX. LOAD w/ R max or Ch max (lbs.)	EDGE MARGIN	R.P.M. LIMITS Standard Material
	H	Tol.	S max	Tol.	S min	Tol.	R	Tol.		Gd Max	R max	Ch max			
**SH-12	.046	±.002	.018	±.0015	.011	±.0015	.026		.148	.010	.006	45	.012	80000	
**SH-15	.054		.026		.016		.026		.189	.015	.009	45	.015	80000	
**SH-18	.050		.025		.016		.025		.218	.014	.0085	105	.018	80000	
**SH-19	.056		.026		.016		.026		.229	.0145	.009	105	.018	80000	
**SH-21	.056		.028		.017		.026		.252	.015	.009	105	.021	80000	
**SH-23	.056	.030	.019	.026	.272	.0165	.010	105	.021	80000					
SH-25	.080	±.003	.035	±.003	.025	±.003	.041	+.010 -.002	.290	.018	.011	470	.030	80000	
SH-27	.081		.035		.024		.041		.315	.0175	.0105	470	.031	76000	
SH-28	.080		.038		.025		.041		.326	.020	.012	470	.030	74000	
SH-31	.087		.040		.026		.041		.357	.020	.012	470	.033	70000	
SH-34	.087		.042		.0265		.041		.390	.021	.0125	470	.033	64000	
SH-35	.087		.046		.029		.041		.405	.023	.014	470	.036	62000	
SH-37	.088		.050		.0305		.041		.433	.026	.0155	470	.036	60000	
SH-39	.087		.052		.031		.041		.452	.027	.016	470	.037	56500	
SH-40	.087		.054		.033		.041		.468	.0285	.017	470	.036	55000	
SH-43	.088		.055		.033		.041		.501	.029	.0175	470	.039	50000	
SH-46SP1	.092	.064	.038	.041	.540	.015	.017	470	.039	42000					
SH-46	.088	.060	.035	.041	.540	.031	.018	470	.039	42000					
SH-50	.108	.065	.040	.047	.574	.034	.020	910	.048	40000					
SH-55	.108	.053	.036	.047	.611	.027	.0165	910	.048	36000					
SH-56	.108	.072	.041	.047	.644	.038	.023	910	.048	35000					
SH-59	.109	.076	.043	.047	.680	.0395	.0235	910	.052	32000					
SH-62	.110	.080	.045	.047	.715	.0415	.025	910	.055	30000					
SH-66	.110	.082	.043	.047	.756	.040	.024	910	.060	29000					
SH-66	.110	.082	.043	.047	.758	.040	.024	910	.060	29000					
SH-68	.136	.084	.048	.052	.779	.042	.025	1340	.063	28000					
SH-75	.136	.092	.051	.052	.850	.046	.0275	1340	.069	26500					
SH-78	.136	.094	.052	.052	.883	.047	.028	1340	.072	25500					
SH-81	.136	.096	.054	.052	.914	.047	.028	1340	.075	24500					
SH-84	.137	.100	.057	.052	.950	.047	.028	1340	.078	24000					
SH-87	.137	.104	.057	.052	.987	.051	.0305	1340	.081	23000					
SH-93	.166	.110	.063	.078	1.054	.055	.033	1340	.084	21500					
SH-98	.167	.114	.064	.078	1.106	.056	.0335	1340	.087	20500					
SH-100	.167	.116	.065	.078	1.122	.057	.034	1340	.090	20000					
SH-102	.168	.118	.066	.078	1.147	.058	.035	1340	.093	19500					
SH-106	.181	.122	.069	.078	1.192	.060	.036	1950	.096	19000					
SH-112	.182	.128	.071	.078	1.261	.063	.038	1950	.099	18800					

FOR HARDNESS SPECIFICATIONS, SEE END OF THIS SECTION.



SH Shaft Rings

Axially Assembled, External

Once installed in the groove of a shaft, the portion of the ring protruding from the groove (also called a "shoulder") holds an assembly in place.

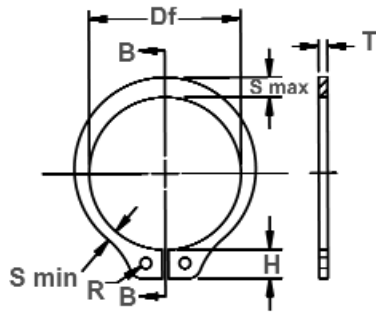

Free Diameter & Ring Measurements with Section B-B

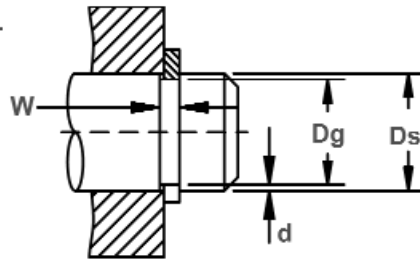

Shaft Diameter & Groove Dimensions

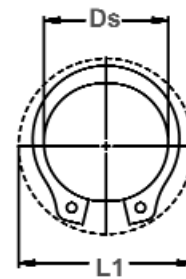

Clearance Diameter Expanded Over Shaft

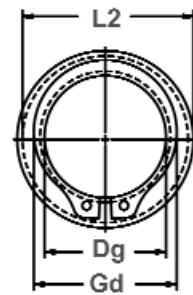

Clearance Diameter & Gaging Diameter Released in Groove.

RING NO.	SHAFT DIAMETER			GROOVE SIZE			RING SIZE & WEIGHT				CLEARANCE DIA.			THRUST LD. (lbs.)			
				DIAMETER		WIDTH	DEPTH	FREE DIAMETER		THICKNESS***		Weight Per 1000 pcs.	Expanded over Shaft	Re-leased in Groove	Sqr. Corner Abutment		
	Ds DEC	Ds FRAC	Ds mm	Dg	Tol.	W	Tol.	d	Df	Tol.	T				Tol.	lbs.	L1
SH-118	1.188	1-3/16	30.2	1.118		.056		.035	1.098		.050		5.6	1.61	1.54	7105	2950
SH-125	1.250	1-1/4	31.7	1.176		.056		.037	1.156		.050		5.9	1.69	1.62	7460	3250
SH-131	1.312	1-5/16	33.3	1.232	±.004	.056		.040	1.214	+.010	.050	±.002	6.8	1.75	1.67	7866	3700
SH-137	1.375	1-3/8	34.9	1.291	.005*	.056		.042	1.272	-.015	.050		7.2	1.80	1.72	8222	4100
SH-143	1.438	1-7/16	36.5	1.350		.056		.044	1.333		.050		8.1	1.87	1.79	8628	4500
SH-150	1.500	1-1/2	38.1	1.406		.056		.047	1.387		.050		9.0	1.99	1.90	8932	5000
SH-156	1.562	1-9/16	39.7	1.468		.068		.047	1.446		.062		12.4	2.10	2.01	11571	5200
SH-162	1.625	1-5/8	41.3	1.529		.068	+.004	.048	1.503		.062		13.2	2.17	2.08	12028	5500
SH-168	1.688	1-11/16	42.9	1.589		.068	-.000	.049	1.560		.062		14.8	2.24	2.15	12535	5850
SH-175	1.750	1-3/4	44.4	1.650	±.005	.068		.050	1.618	+.013	.062		15.3	2.31	2.21	12992	6200
SH-177	1.772	-	45.0	1.669	.005*	.068		.051	1.637	-.020	.062		15.4	2.33	2.23	13144	6400
SH-181	1.812	1-13/16	46.0	1.708		.068		.052	1.675		.062		15.6	2.38	2.28	13449	6650
SH-187	1.875	1-7/8	47.6	1.769		.068		.053	1.735		.062		17.3	2.44	2.34	13906	7000
SH-196	1.969	1-31/32	50.0	1.857		.068		.056	1.819		.062		18.0	2.57	2.46	14565	7800
SH-200	2.000	2	50.8	1.886		.068		.057	1.850		.062		19.0	2.60	2.49	14819	8050
SH-206	2.062	2-1/16	52.4	1.946		.086		.058	1.906		.078		25.0	2.68	2.50	19234	8450
SH-212	2.125	2-1/8	54.0	2.003		.086		.061	1.964		.078		26.1	2.78	2.66	19793	9150
SH-215	2.156	2-5/32	54.8	2.032		.086		.062	1.993		.078		26.3	2.81	2.69	20097	9450
SH-225	2.250	2-1/4	57.1	2.120		.086		.065	2.081	+.015	.078	±.003	27.7	2.88	2.76	21011	10350
SH-231	2.312	2-5/16	58.7	2.178		.086		.067	2.139	-.025	.078		28.0	2.94	2.81	21518	10950
SH-237	2.375	2-3/8	60.3	2.239		.086		.068	2.197		.078		29.2	3.06	2.93	22127	11400
SH-243	2.438	2-7/16	61.9	2.299		.086		.069	2.255		.078		29.5	3.07	2.94	22736	11900
SH-250	2.500	2-1/2	63.5	2.360		.086		.070	2.313		.078		29.7	3.17	3.03	23345	12350
SH-255	2.559	-	65.0	2.419		.086		.070	2.377		.078		33.9	3.18	3.04	23853	12650
SH-262	2.625	2-5/8	66.7	2.481	±.006	.086	+.005	.072	2.428		.078		35.0	3.30	3.16	24462	13350
SH-268	2.688	2-11/16	68.3	2.541	.006*	.086	-.000	.073	2.485		.078		36.0	3.37	3.23	25071	13850
SH-275	2.750	2-3/4	69.8	2.602		.103		.074	2.543		.093		42.5	3.48	3.34	30551	14400
SH-287	2.875	2-7/8	73.0	2.721		.103		.077	2.659		.093		48.5	3.60	3.45	31973	15650
SH-293	2.938	2-15/16	74.6	2.779		.103		.079	2.717	+.020	.093		50.0	3.66	3.51	32683	16400
SH-300	3.000	3	76.2	2.838		.103		.081	2.775	-.030	.093		52.0	3.60	3.44	33394	17200
SH-306	3.062	3-1/16	77.8	2.898		.103		.082	2.832		.093		47.5	3.74	3.58	34003	17750
SH-312	3.125	3-1/8	79.4	2.957		.103		.084	2.892		.093		58.0	3.85	3.69	34815	18550
SH-315	3.156	3-5/32	80.2	2.986		.103		.085	2.920		.093		59.0	3.88	3.71	35119	18950
SH-325	3.250	3-1/4	82.5	3.076		.103		.087	3.006		.093		62.0	3.93	3.76	36134	20000
SH-334	3.346	3-11/32	85.0	3.166		.103		.090	3.092		.093		64.0	4.02	3.85	37251	21000
SH-343	3.438	3-7/16	87.3	3.257		.103		.090	3.179		.093		66.0	4.14	3.96	38266	21900
SH-350	3.500	3-1/2	88.9	3.316		.120		.092	3.237		.109		72.0	4.16	3.98	45574	22800

* F.I.M. (FULL INDICATOR MOVEMENT)- MAXIMUM ALLOWABLE DEVIATION OF CONCENTRICITY BETWEEN GROOVE & SHAFT.
 † BASED ON HOUSINGS/SHAFTS MADE OF COLD ROLLED STEEL. FOR AN EXPLANATION OF FORMULAS USED TO DERIVE THRUST LOAD AND OTHER PERFORMANCE DATA CONTACT THE ROTOR CLIP ENGINEERING DEPARTMENT.
 ***FOR PLATED RINGS ADD .002" TO THE LISTED MAXIMUM THICKNESS. MAXIMUM THICKNESS WILL BE A MINIMUM OF .0002" LESS THAN THE LISTED GROOVE WIDTH (W) MINIMUM.



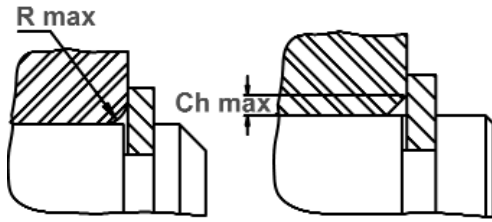

Maximum Corner Radius & Chamfer

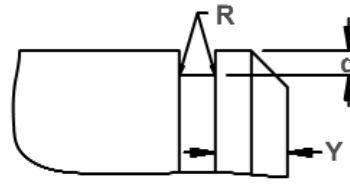

Exploded Groove Profile & Edge Margin (Y)
Maximum bottom radii (R), sharp corners for ring sizes -12 thru -23; .003 for ring sizes -25 thru -35; .005 for sizes -37 thru -100; .010 for ring sizes -102 thru -1000

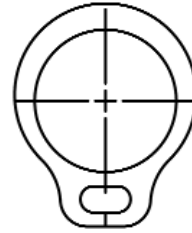

Lug Design For Sizes SH-12 thru SH-23

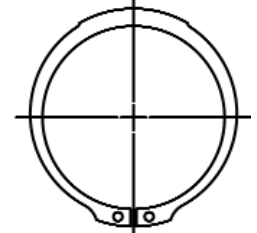

Alternate Design Manufacturer's Option

RING NO.	LUG HEIGHT		MAXIMUM SECTION		MINIMUM SECTION		HOLE DIAMETER		GAGING DIA. Gd Max.	ALLOWABLE CORNER RADII & CHAMFERS		MAX. LOAD w/ R max or Ch max (lbs.) P'r	EDGE MARGIN Y	R.P.M. LIMITS Standard Material RPM
	H	Tol.	S max	Tol.	S min	Tol.	R	Tol.		R max	Ch max			
SH-118	.182		.132		.072		.078		1.325	.064	.0385	1950	.105	18000
SH-125	.183		.140		.076		.078		1.396	.068	.041	1950	.111	17000
SH-131	.183		.146		.076		.078		1.458	.068	.041	1950	.120	16500
SH-137	.184		.152		.082		.078		1.529	.072	.043	1950	.126	16000
SH-143	.184		.160		.086		.078		1.600	.076	.045	1950	.132	15000
SH-150	.214	±.004	.168	±.006	.091	±.006	.120		1.668	.079	.047	1950	.141	14800
SH-156	.235		.172		.093		.125		1.740	.082	.049	3000	.141	14000
SH-162	.235		.180		.097		.125		1.812	.087	.052	3000	.144	13200
SH-168	.235		.184		.099		.125		1.877	.090	.054	3000	.148	13000
SH-175	.237		.188		.101		.125		1.945	.091	.054	3000	.150	12200
SH-177	.237		.190		.102		.125		1.967	.092	.055	3000	.154	11700
SH-181	.262		.192		.102		.125		2.010	.092	.055	3000	.156	11500
SH-187	.262		.196		.104		.125		2.076	.094	.056	3000	.159	11000
SH-196	.262		.200		.106		.125		2.170	.094	.056	3000	.168	10500
SH-200	.262		.204		.108		.125		2.205	.096	.057	3000	.171	10000
SH-206	.267		.208		.111		.125		2.275	.098	.059	5000	.174	9600
SH-212	.280		.212		.113		.125	+ .015 - .002	2.337	.098	.059	5000	.183	9500
SH-215	.280		.212		.113		.125		2.366	.097	.058	5000	.186	9400
SH-225	.280		.220		.116		.125		2.466	.100	.060	5000	.195	9200
SH-231	.280		.222		.118		.125		2.528	.100	.060	5000	.201	9000
SH-237	.292		.224		.119		.125		2.591	.100	.060	5000	.204	8800
SH-243	.268	±.005	.228	±.007	.120	±.007	.125		2.657	.102	.061	5000	.207	8600
SH-250	.292		.232		.122		.125		2.724	.104	.062	5000	.210	8400
SH-255	.268		.238		.125		.125		2.792	.108	.065	5000	.210	8200
SH-262	.292		.242		.127		.125		2.860	.1095	.066	5000	.216	8000
SH-268	.268		.246		.129		.125		2.926	.1115	.067	5000	.219	7900
SH-275	.324		.248		.131		.125		2.992	.112	.067	7350	.222	7600
SH-287	.324		.256		.133		.125		3.122	.115	.069	7350	.231	7300
SH-293	.324		.260		.136		.125		3.187	.116	.070	7350	.237	7200
SH-300	.264		.264		.138		.125		3.252	.117	.070	7350	.243	6700
SH-306	.298		.252		.131		.125		3.294	.107	.064	7350	.246	6600
SH-312	.324		.272		.141		.125		3.383	.120	.072	7350	.252	6600
SH-315	.324		.274		.143		.125		3.415	.1205	.072	7350	.255	6500
SH-325	.300		.300	±.008	.145	±.008	.125		3.515	.123	.074	7350	.261	6400
SH-334	.300		.300		.147		.125		3.613	.126	.076	7350	.270	6000
SH-343	.308		.292		.148		.125		3.712	.129	.077	7350	.270	5900
SH-350	.285		.285		.148		.125		3.764	.122	.073	10500	.276	5900

FOR HARDNESS SPECIFICATIONS, SEE END OF THIS SECTION.



SH Shaft Rings

Axially Assembled, External

Once installed in the groove of a shaft, the portion of the ring protruding from the groove (also called a "shoulder") holds an assembly in place.

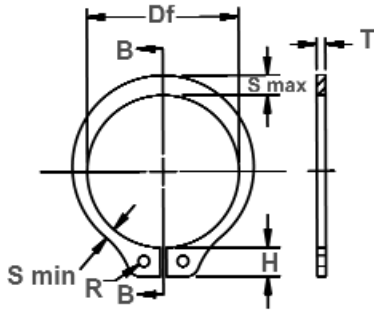

Free Diameter & Ring Measurements with Section B-B

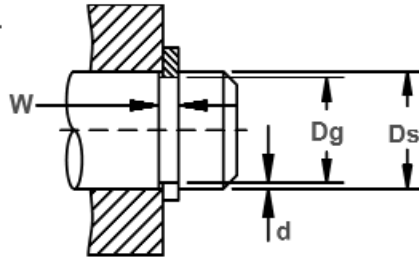

Shaft Diameter & Groove Dimensions

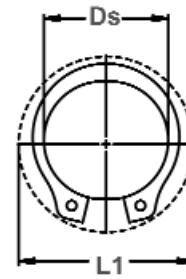

Clearance Diameter Expanded Over Shaft

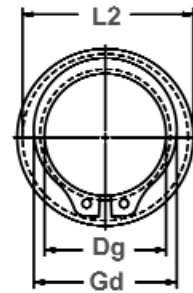

Clearance Diameter & Gaging Diameter Released in Groove.

RING NO.	SHAFT DIAMETER			GROOVE SIZE			RING SIZE & WEIGHT					CLEARANCE DIA.			i THRUST LD.(lbs.) Sqr. Corner Abutment		
				DIAMETER	WIDTH	DEPTH	FREE DIAMETER	THICKNESS***	Weight Per 1000 pcs.	Ex-panded over Shaft	Re-leased in Groove	Ring Safety Factor of 4	Groove Safety Factor of 2				
	Dg	Tol.	W											Tol.	d	Df	Tol.
SH-354	3.543	-	90.0	3.357	.120		.093	3.277		.109		73.0	4.25	4.07	46183	23300	
SH-362	3.625	3-5/8	92.1	3.435	.120		.095	3.352		.109		76.0	4.36	4.17	47299	24300	
SH-368	3.688	3-11/16	93.7	3.493	.120		.097	3.410		.109		80.0	4.33	4.31	48010	25300	
SH-375	3.750	3-3/4	95.2	3.552	±.006	.120	+.005	.099	3.468	+.020	.109	±.003	83.0	4.52	4.33	48822	26200
SH-387	3.875	3-7/8	98.40	3.673	.006*	.120	-.000	.101	3.584	-.030	.109		88.0	4.64	4.44	50446	27700
SH-393	3.938	3-15/16	100.0	3.734		.120		.102	3.642		.109		95.0	4.70	4.50	51359	28400
SH-400	4.000	4	101.6	3.792		.120		.104	3.700		.109		101.0	4.76	4.56	52171	29400
SH-412	4.125	4-1/8	104.8	3.915		.120		.105	3.800		.109		101.2	5.00	4.78	53200	29800
SH-425	4.250	4-1/4	108.0	4.065		.120		.092	3.989		.109		112.0	4.98	4.80	55419	27600
SH-437	4.375	4-3/8	111.1	4.190		.120		.092	4.106		.109		115.0	5.22	5.04	57043	28400
SH-450	4.500	4-1/2	114.3	4.310		.120		.095	4.223		.109		132.0	5.37	5.18	58667	30200
SH-475	4.750	4-3/4	120.6	4.550		.120		.100	4.458		.109		113.0	5.74	5.52	61915	33600
SH-500	5.000	5	127.0	4.790		.120		.105	4.692		.109		149.0	5.85	5.64	65163	37100
SH-525	5.250	5-1/4	133.3	5.030		.139		.110	4.927		.125		190.0	6.17	5.95	78460	40800
SH-550	5.500	5-1/2	139.7	5.265	±.007	.139	+.006	.117	5.162	+.020	.125	±.004	202.5	6.63	6.39	82215	45500
SH-575	5.750	5-3/4	146.0	5.505	.006*	.139	-.000	.122	5.396	-.040	.125		220.0	6.93	6.69	85971	49600
SH-600	6.000	6	152.4	5.745		.139		.127	5.631		.125		210.0	7.21	6.95	89625	53800
SH-625	6.250	6-1/4	158.7	5.985		.174		.132	5.866		.156		282.0	7.48	7.22	116522	58300
SH-650	6.500	6-1/2	165.1	6.225		.174		.137	6.100	+.020	.156		330.0	7.80	7.45	121191	62900
SH-675	6.750	6-3/4	171.4	6.465		.174		.142	6.335	-.050	.156		356.0	8.10	7.82	125860	67700
SH-700	7.000	7	177.8	6.705		.174		.147	6.570		.156		371.0	7.86	7.78	130529	72700
SH-725	7.250	7-1/4	184.2	6.942		.209		.154	6.775		.187		510.0	7.59	8.13	162096	78900
SH-750	7.500	7-1/2	190.5	7.180		.209		.160	7.009		.187		534.0	8.73	8.41	167678	84800
SH-775	7.750	7-3/4	196.9	7.420	±.008	.209	+.008	.165	7.243	+.050	.187	±.005	545.0	8.85	8.52	173261	90450
SH-800	8.000	8	203.2	7.660	.006*	.209	-.000	.170	7.478	-.130	.187		640.0	9.25	8.91	178843	96100
SH-825	8.250	8-1/4	209.6	7.900		.209		.175	7.712		.187		665.0	9.54	9.19	184426	102100
SH-850	8.500	8-1/2	215.9	8.140		.209		.180	7.947		.187		692.0	9.79	9.43	190008	108100
SH-875	8.750	8-3/4	222.3	8.380		.209		.185	8.181		.187		712.0	10.40	10.00	195591	114450
SH-900	9.000	9	228.6	8.620		.209		.190	8.415		.187		737.0	10.60	10.22	201173	120800
SH-925	9.250	9-1/4	234.9	8.860		.209		.195	8.650		.187		760.0	10.85	10.50	206756	128225
SH-950	9.500	9-1/2	241.3	9.100		.209		.200	8.885		.187		785.0	11.10	10.70	212338	134200
SH-975	9.750	9-3/4	247.6	9.338		.209		.206	9.120		.187		845.0	11.35	10.95	217921	142000
SH-1000	10.000	10	254.0	9.575		.209		.212	9.355		.187		910.0	11.60	11.20	223503	149800

* F.I.M. (FULL INDICATOR MOVEMENT)- MAXIMUM ALLOWABLE DEVIATION OF CONCENTRICITY BETWEEN GROOVE & SHAFT.

i BASED ON HOUSINGS/SHAFTS MADE OF COLD ROLLED STEEL. FOR AN EXPLANATION OF FORMULAS USED TO DERIVE THRUST LOAD AND OTHER PERFORMANCE DATA CONTACT THE ROTOR CLIP ENGINEERING DEPARTMENT.

***FOR PLATED RINGS ADD .002" TO THE LISTED MAXIMUM THICKNESS. MAXIMUM THICKNESS WILL BE A MINIMUM OF .0002" LESS THAN THE LISTED GROOVE WIDTH (W) MINIMUM.

HARDNESS RANGES: STAINLESS STEEL RINGS (PH 15-7MO)

RING TYPE	SIZE RANGE	SCALE	ROCKWELL HARDNESS
SH	25-81	30N	63-69.5
	87+	C	44-51



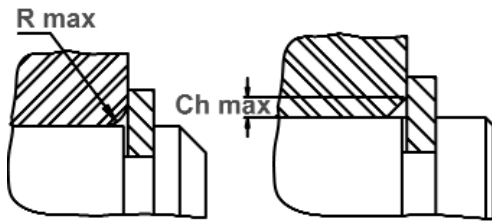

Maximum Corner Radius & Chamfer

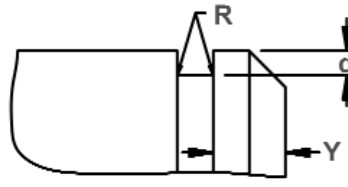

Exploded Groove Profile & Edge Margin (Y)
Maximum bottom radii (R), sharp corners for ring sizes -12 thru -23; .003 for ring sizes -25 thru -35; .005 for sizes -37 thru -100; .010 for ring sizes -102 thru -1000



Lug Design For Sizes SH-12 thru SH-23

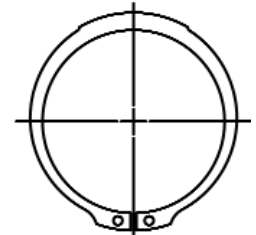

Alternate Design Manufacturer's Option

RING NO.	LUG HEIGHT		MAXIMUM SECTION		MINIMUM SECTION		HOLE DIAMETER		GAGING DIA. Gd Max.	ALLOWABLE CORNER RADII & CHAMFERS		MAX. LOAD w/ R max or Ch max (lbs.)	EDGE MARGIN Y	R.P.M. LIMITS Standard Material RPM
	H	Tol.	S max	Tol.	S min	Tol.	R	Tol.		R max	Ch max			
SH-354	.310		.310		.149		.125		3.809	.123	.074	10500	.279	5800
SH-362	.310		.310		.153		.125		3.898	.127	.076	10500	.285	5700
SH-368	.310		.310		.156		.125	+.015	3.966	.130	.078	10500	.291	5600
SH-375	.342	±.005	.342	±.008	.160	±.008	.125	-.002	4.037	.133	.080	10500	.297	5500
SH-387	.342		.342		.163		.125		4.169	.137	.082	10500	.303	5100
SH-393	.342		.342		.163		.125		4.230	.137	.082	10500	.306	5200
SH-400	.342		.342		.163		.125		4.288	.135	.081	10500	.312	5000
SH-412	.380		.318		.165		.125		4.410	.135	.081	10500	.315	4900
SH-425	.342		.342		.176		.125		4.558	.146	.088	10500	.276	4800
SH-437	.342		.342		.176		.125		4.683	.146	.088	10500	.276	4700
SH-450	.405		.405		.185		.125		4.860	.102	.061	10500	.285	4500
SH-475	.429		.303		.136		.125		4.996	.115	.069	10500	.300	4200
SH-500	.405	±.008	.405	±.010	.194	±.010	.156		5.346	.165	.099	10500	.315	4000
SH-525	.435		.435		.211		.156		5.605	.169	.101	13500	.330	3900
SH-550	.497		.435		.209		.156		5.867	.175	.105	13500	.351	3700
SH-575	.518		.435		.220		.156		6.134	.184	.110	13500	.366	3500
SH-600	.540		.435		.171		.156		6.302	.143	.086	13500	.381	3400
SH-625	.561		.485		.176		.156		6.568	.148	.089	21000	.396	3100
SH-650	.586		.485		.236		.156		6.905	.191	.114	21000	.411	3000
SH-675	.608		.515		.246		.187	+.020	7.172	.200	.120	21000	.426	3000
SH-700	.530		.515		.256		.187	-.005	7.439	.208	.125	21000	.441	2900
SH-725	.660		.545		.267		.187		7.700	.214	.128	30000	.460	2800
SH-750	.676		.545		.277		.187		7.963	.220	.132	30000	.480	2700
SH-775	.660	±.012	.560	±.015	.285	±.015	.187		8.228	.227	.136	30000	.495	2600
SH-800	.560		.560		.294		.187		8.493	.235	.141	30000	.510	2500
SH-825	.580		.580		.304		.187		8.758	.242	.146	30000	.525	2400
SH-850	.580		.580		.314		.187		9.023	.250	.150	30000	.540	2300
SH-875	.735		.591		.322		.187		9.280	.258	.155	30000	.555	2200
SH-900	.735		.609		.333		.187		9.557	.267	.160	30000	.570	2200
SH-925	.735		.625		.341		.187		9.830	.274	.164	30000	.585	2100
SH-950	.735		.642		.350		.187		10.086	.281	.168	30000	.600	2100
SH-975	.735		.658		.358		.187		10.340	.287	.172	30000	.618	2000
SH-1000	.735		.675		.367		.187		10.610	.294	.176	30000	.636	2000

LARGER SIZES MAY BE AVAILABLE UPON REQUEST.

HARDNESS RANGES: CARBON STEEL RINGS (SAE 1060-1090)

RING TYPE	SIZE RANGE	SCALE	ROCKWELL HARDNESS
SH	12-23	15N	86-88
	25-46	30N	69.5-73
	50-81	30N	66-71
	84-102	C	47-53
	106-343	C	47-52
	350-700	C	44-51
	725-1000	C	40-47

HARDNESS RANGES: BERYLLIUM COPPER RINGS

RING TYPE	SIZE RANGE	SCALE	ROCKWELL HARDNESS
SH	12-23	15N	77-82*
	25-102	30N	56.5-62
	106+	C	37-43

*HARDNESS CAN NOT BE CHECKED WITH ANY DEGREE OF ACCURACY DIRECTLY ON THESE RINGS.





HOI Housing Rings

Axially Assembled, Internal Inverted

Functions like an HO ring in a housing/bore, only the lugs are "reversed." This version reduces the distance the lugs of the standard HO extend into the inner circumference of the housing/bore and allows for another assembly to pass through unimpeded.

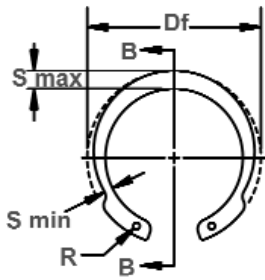

Free Diameter & Ring Measurements with Section B-B

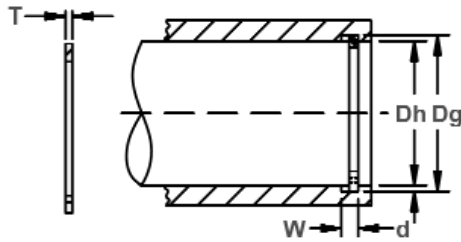

Housing Diameter & Groove Dimensions

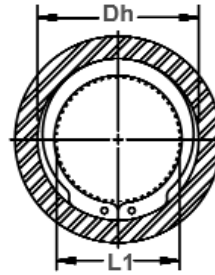

Clearance Diameter Compressed in Housing

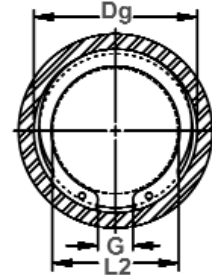

Clearance Diameter & Gap Width Released in Groove

RING NO.	HOUSING DIAMETER			GROOVE SIZE			RING SIZE & WEIGHT				CLEARANCE DIA.			THRUST LD. (lbs.)			
				DIAMETER	WIDTH		DEPTH	FREE DIAMETER	THICKNESS***		Wght. Per 1000 Pcs.	Compressed in housing	Released in groove	Sqr. Corner Abutment			
	Dg	Tol.	W		Tol.	d			Df	Tol.				T	Tol.	Lbs.	L1
HOI-62	.625	5/8	15.9	.665	±.002	.029		.020	.675		.025		0.7	.47	.51	1015	450
HOI-75	.750	3/4	19.0	.796	.004*	.039		.023	.808		.035		1.3	.56	.605	1675	600
HOI-81	.812	13/16	20.6	.862		.046	+ .003	.025	.877	+ .010	.042		2.0	.62	.665	2639	700
HOI-87	.875	7/8	22.2	.931	±.003	.046	-.000	.028	.944	-.005	.042		2.2	.65	.705	2893	850
HOI-93	.938	15/16	23.8	1.000	.004*	.046		.031	1.015		.042		2.8	.70	.755	3147	1000
HOI-100	1.000	1	25.4	1.066		.046		.033	1.081		.042		2.9	.75	.81	3350	1150
HOI-106	1.062	1-1/16	27.0	1.130		.056		.034	1.150		.050		3.8	.80	.87	4212	1250
HOI-112	1.125	1-1/8	28.6	1.197		.056		.036	1.217		.050		4.4	.86	.93	4466	1400
HOI-118	1.188	1-3/16	30.2	1.262		.056		.037	1.283	+ .015	.050	±.002	4.9	.91	.98	4720	1600
HOI-125	1.250	1-1/4	31.7	1.330	±.004	.056		.040	1.351	-.010	.050		5.0	.97	1.05	4974	1750
HOI-131	1.312	1-5/16	33.3	1.396	.005*	.056	+ .004	.042	1.418		.050		5.3	1.02	1.10	5227	1950
HOI-137	1.375	1-3/8	34.9	1.461		.056	-.000	.043	1.486		.050		5.9	1.08	1.16	5481	2100
HOI-143	1.438	1-7/16	36.5	1.528		.056		.045	1.552		.050		6.3	1.13	1.22	5735	2300
HOI-150	1.500	1-1/2	38.1	1.594		.056		.047	1.622		.050		6.8	1.18	1.27	5938	2500
HOI-156	1.562	1-9/16	39.7	1.658		.068		.048	1.688		.062		8.9	1.21	1.30	7714	2650
HOI-162	1.625	1-5/8	41.3	1.725		.068		.050	1.756		.062		10.4	1.27	1.37	8019	2850
HOI-168	1.688	1-11/16	42.9	1.792	±.005	.068		.052	1.823	+ .020	.062		11.9	1.32	1.42	8374	3100
HOI-175	1.750	1-3/4	44.4	1.858	.005*	.068		.054	1.891	-.013	.062		11.8	1.38	1.49	8678	3300
HOI-187	1.875	1-7/8	47.6	1.989		.068		.057	2.025		.062		14.8	1.47	1.58	9287	3750
HOI-200	2.000	2	50.8	2.122		.068		.061	2.160		.062		17.4	1.55	1.67	9896	4300
HOI-206	2.062	2-1/16	52.4	2.186		.086		.062	2.224		.078		23.2	1.59	1.71	12840	4500
HOI-212	2.125	2-1/8	54.0	2.251	±.006	.086	+ .005	.063	2.295		.078		24.3	1.65	1.77	13246	4700
HOI-237	2.375	2-3/8	60.3	2.517	.006*	.086	-.000	.071	2.567	+ .025	.078	±.003	28.6	1.86	2.00	14718	5900
HOI-243	2.438	2-7/16	61.9	2.584		.086		.072	2.634	-.015	.078		30.6	1.91	2.05	15124	6200
HOI-250	2.500	2-1/2	63.5	2.648		.086		.074	2.700		.078		32.1	1.96	2.10	15530	6500
HOI-262	2.625	2-5/8	66.7	2.781		.103		.078	2.840		.093		45.6	2.06	2.21	19488	7200
HOI-275	2.750	2-3/4	69.8	2.914		.103		.082	2.975		.093		47.8	2.16	2.32	20300	7900
HOI-283	2.812	2-13/16	71.4	2.980		.103		.084	3.063		.093		49.5	2.21	2.37	20808	8300
HOI-283	2.835	-	72.0	3.006		.103		.086	3.063		.093		49.5	2.23	2.39	20808	8550
HOI-287	2.875	2-7/8	73.0	3.051		.103		.088	3.105	+ .030	.093		50.1	2.26	2.43	21315	8900
HOI-300	3.000	3	76.2	3.182		.103		.091	3.245	-.020	.093		52.6	2.36	2.53	22229	9600
HOI-315	3.156	3-5/32	80.2	3.348		.120		.096	3.408		.109		69.4	2.50	2.69	27405	10600
HOI-325	3.250	3-1/4	82.5	3.446		.120		.098	3.509		.109		72.6	2.58	2.77	28217	11200
HOI-334	3.346	3-11/32	85.0	3.546		.120		.100	3.611		.109		75.6	2.67	2.87	29029	11700
HOI-350	3.500	3-1/2	88.9	3.710		.120		.105	3.780		.109		80.2	2.82	3.03	30349	12900
HOI-356	3.562	3-9/16	90.5	3.776		.120		.107	3.850		.109		82.4	2.88	3.09	30958	13400
HOI-400	4.000	4	101.6	4.240		.120		.120	4.350		.109		97.4	3.29	3.53	34713	16900

*F.I.M. (FULL INDICATOR MOVEMENT)-MAXIMUM ALLOWABLE DEVIATION OF CONCENTRICITY BETWEEN GROOVE AND HOUSING.

† BASED ON HOUSING/SHAFTS MADE OF COLD ROLLED STEEL. FOR AN EXPLANATION OF FORMULAS USED TO DERIVE THRUST LOAD AND OTHER PERFORMANCE DATA, CONTACT THE ROTOR CLIP ENGINEERING DEPT.

*** FOR PLATED RINGS, ADD .002" TO THE LISTED MAXIMUM THICKNESS. MAXIMUM RING THICKNESS WILL BE A MINIMUM OF .0002" LESS THAN THE LISTED GROOVE WIDTH (W) MINIMUM.

HARDNESS RANGES: STAINLESS STEEL RINGS (PH 15-7MO)

RING TYPE	SIZE RANGE	SCALE	ROCKWELL HARDNESS
HOI	62-100	30N	63-69.5
	106+	C	44-51



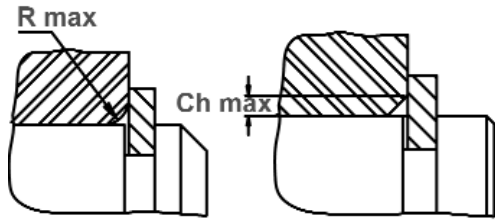

Allowable Corner Radius & Chamfer

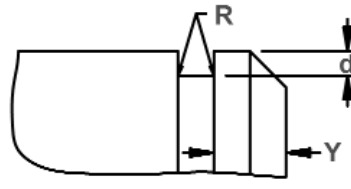

Exploded Groove Profile & Edge Margin (Y) Maximum bottom radii (R), .005 for ring sizes -62 thru -100; .010 for ring sizes -106 thru -400

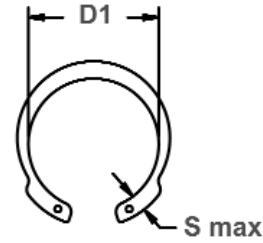

Measuring Free Diameter (Df) HOI Series $Df = D1 + 2(S \text{ max})$

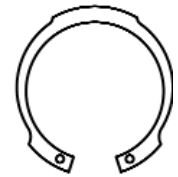

Alternate Design Manufacturer's Option

RING NO.	MAXIMUM SECTION Including lug		MINIMUM SECTION		HOLE DIAMETER		GAP WIDTH Ring in groove	Allowable Corner Radii & Chamfers			MAX LOAD W/R Max or Ch Max	EDGE MARGIN
	S max	Tol.	S min.	Tol.	R	Tol.		G Min	R max	Ch max		
HOI-62	.072	±.004	.036	±.004	.030	+.010 -.002	.15	.042	.028	400	.060	
HOI-75	.085	±.005	.042	±.005	.042		.175	.050	.031	850	.069	
HOI-81	.092		.044		.042		.175	.054	.034	1250	.075	
HOI-87	.099		.047		.042		.20	.057	.036	1250	.084	
HOI-93	.106		.051		.042		.21	.060	.038	1250	.093	
HOI-100	.113		.054		.042		.225	.064	.040	1250	.099	
HOI-106	.120		.057		.050		.24	.069	.043	1800	.102	
HOI-112	.123		.059		.050		.24	.070	.044	1800	.108	
HOI-118	.126		.060		.050		.27	.071	.045	1800	.111	
HOI-125	.129		.061		.050		.29	.071	.045	1800	.120	
HOI-131	.132		.063		.050	.29	.072	.045	1800	.126		
HOI-137	.135	.065	.050	.33	.074	.046	1800	.129				
HOI-143	.144	.069	.076	.35	.079	.050	1800	.135				
HOI-150	.148	.070	.076	.33	.081	.051	1800	.141				
HOI-156	.158	.074	.076	.36	.088	.055	2900	.144				
HOI-162	.162	.077	.076	.385	.090	.056	2900	.150				
HOI-168	.166	.079	.076	.405	.091	.057	2900	.156				
HOI-175	.170	.082	.076	.42	.093	.058	2900	.162				
HOI-187	.188	.090	.076	.44	.105	.066	2900	.171				
HOI-200	.208	.100	.076	.48	.118	.074	2900	.183				
HOI-206	.218	.106	.094	.485	.125	.078	4600	.186				
HOI-212	.223	.108	.094	.49	.128	.080	4600	.189				
HOI-237	.243	.115	.094	.55	.138	.086	4600	.213				
HOI-243	.248	.117	.094	.57	.141	.088	4600	.216				
HOI-250	.254	.120	.094	.59	.144	.090	4600	.222				
HOI-262	.266	.128	.109	.60	.150	.094	6700	.234				
HOI-275	.278	.134	.109	.63	.157	.098	6700	.246				
HOI-283	.286	.139	.109	.61	.162	.102	6700	.252				
HOI-283	.286	.139	.109	.67	.162	.102	6700	.258				
HOI-287	.290	.139	.109	-	.162	.101	6700	.264				
HOI-300	.302	.143	.109	.705	.169	.106	6700	.273				
HOI-315	.314	.149	.125	.76	.174	.109	9000	.288				
HOI-325	.318	.151	.125	-	.176	.110	9000	.294				
HOI-334	.321	.155	.125	.81	.177	.111	9000	.300				
HOI-350	.324	.154	.125	.84	.175	.110	9000	.315				
HOI-356	.326	.155	.125	.86	.175	.110	9000	.321				
HOI-400	.338	.161	.125	.93	.174	.108	9000	.360				

LARGER SIZES MAY BE AVAILABLE UPON REQUEST.

HARDNESS RANGES: CARBON STEEL RINGS (SAE 1060-1090)

RING TYPE	SIZE RANGE	SCALE	ROCKWELL HARDNESS
HOI	62 & 75	30N	67.5-72
	81-100	30N	66-71
	106-343	C	47-52
	350+	C	45-50

HARDNESS RANGES: BERYLLIUM COPPER RINGS

RING TYPE	SIZE RANGE	SCALE	ROCKWELL HARDNESS
HOI	62-100	30N	56.5-62
	106+	C	37-43





SHI Shaft Rings

Axially Assembled, External Inverted

Functions like an SH ring on a shaft, only the lugs are "reversed." This version reduces the distance the lugs of the standard SH extend beyond the circumference of the shaft. The shaft can then be used in an application where clearance is minimal.

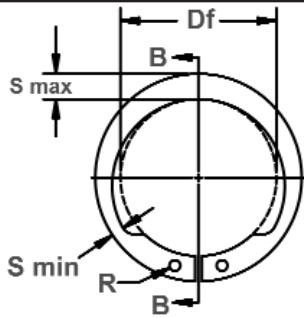

Free Diameter & Ring Measurements with Section B-B

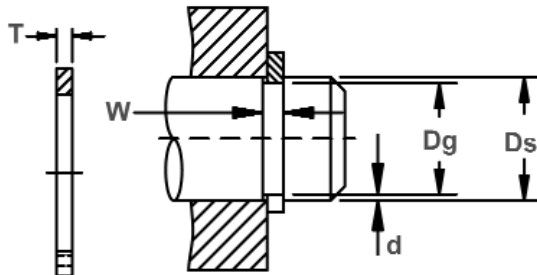

Shaft Diameter & Groove Dimensions

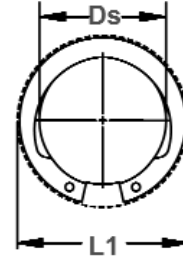

Clearance Diameter Expanded Over Shaft

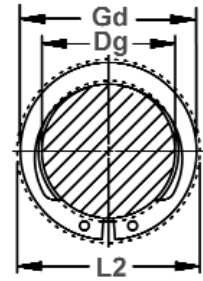

Clearance Diameter & Gaging Diameter Released in Groove

RING NO.	SHAFT DIAMETER			GROOVE SIZE					RING SIZE & WEIGHT				CLEAR. DIA.			† THRUST LD. (lbs.) Sqr. corner abutment	
				DIAMETER		WIDTH		DEPTH	FREE DIAMETER		THICKNESS***		Weight Per 1000 Pcs.	Expanded over shaft	Re-leased in groove	Ring Safety factor of 4	Groove Safety factor of 2
	Ds DEC	Ds FRACT	Ds mm	Dg	Tol.	W	Tol.	d	Df	Tol.	T	Tol.					
SHI-50	.500	1/2	12.7	.468	±.002	.039		.016	.461		.035		1.0	.67	.645	1117	280
SHI-56	.562	9/16	14.3	.530	.004*	.039		.016	.521		.035		1.4	.75	.72	1269	320
SHI-59	.594	19/32	15.1	.559		.039		.017	.550		.035		1.6	.79	.76	1320	370
SHI-62	.625	5/8	15.9	.588		.039		.018	.579		.035		1.6	.83	.80	1421	400
SHI-68	.688	11/16	17.5	.646		.046		.021	.635		.042		2.5	.91	.87	2335	500
SHI-75	.750	3/4	19.0	.704	±.003	.046	+.003	.023	.693	+.005	.042		2.8	.99	.95	2538	600
SHI-78	.781	25/32	19.8	.733	.004*	.046	-.000	.024	.722	-.010	.042		3.1	1.04	1.00	2639	650
SHI-81	.812	13/16	20.6	.762		.046		.025	.751		.042		3.3	1.08	1.03	2690	700
SHI-87	.875	7/8	22.2	.821		.046		.027	.810		.042		3.8	1.15	1.10	2893	850
SHI-93	.938	15/16	23.8	.882		.046		.028	.867		.042		4.5	1.23	1.18	3147	900
SHI-100	.984	63/64	25.0	.926		.046		.029	.925		.042	±.002	4.8	1.30	1.25	3350	1000
SHI-100	1.000	1	25.4	.940		.046		.030	.925		.042		4.8	1.31	1.26	3350	1050
SHI-106	1.062	1-1/16	27.0	.998		.056		.032	.982		.050		6.2	1.38	1.32	4212	1200
SHI-112	1.125	1-1/8	28.6	1.059		.056		.033	1.041		.050		6.7	1.45	1.39	4466	1300
SHI-118	1.188	1-3/16	30.2	1.118		.056		.035	1.098	+.010	.050		7.2	1.52	1.46	4720	1450
SHI-125	1.250	1-1/4	31.7	1.176	±.004	.056	+.004	.037	1.156	-.015	.050		7.6	1.59	1.52	4974	1600
SHI-131	1.312	1-5/16	33.3	1.232	.005*	.056	-.000	.040	1.214		.050		8.2	1.66	1.58	5227	1850
SHI-137	1.375	1-3/8	34.9	1.291		.056		.042	1.272		.050		8.4	1.73	1.65	5481	2050
SHI-143	1.438	1-7/16	36.5	1.350		.056		.044	1.333		.050		9.1	1.80	1.72	5735	2200
SHI-150	1.500	1-1/2	38.1	1.406		.056		.047	1.387		.050		9.8	1.87	1.78	5938	2500
SHI-156	1.562	1-9/16	39.7	1.468		.068		.047	1.446		.062		12.9	1.95	1.86	7714	2600
SHI-162	1.625	1-5/8	41.3	1.529		.068		.048	1.503		.062		13.4	2.02	1.93	8019	2750
SHI-177	1.750	1-3/4	44.4	1.650		.068		.050	1.637		.062		16.1	2.18	2.08	8628	3100
SHI-177	1.772	-	45.0	1.669	±.005	.068		.051	1.637	+.013	.062		16.1	2.20	2.10	8628	3200
SHI-181	1.812	1-13/16	46.0	1.708	.005*	.068		.052	1.675	-.020	.062		17.3	2.24	2.14	8983	3300
SHI-196	1.969	1-31/32	50.0	1.857		.068		.056	1.819		.062		20.5	2.43	2.32	9693	3900
SHI-200	2.000	2	50.8	1.886		.068		.057	1.850		.062		20.7	2.47	2.36	9896	4000
SHI-215	2.125	2-1/8	54.0	2.003		.086		.061	1.993		.078	±.003	30.0	2.62	2.50	13195	4550
SHI-215	2.156	2-5/32	54.8	2.032		.086		.062	1.993	+.015	.078		30.0	2.65	2.53	13195	4700
SHI-250	2.500	2-1/2	63.5	2.360		.086		.070	2.313	-.025	.078		43.5	3.05	2.92	15530	6200
SHI-275	2.750	2-3/4	69.8	2.602	±.006	.103	+.005	.074	2.543		.093		57.9	3.34	3.20	20402	7200
SHI-287	2.875	2-7/8	73.0	2.721	.006*	.103	-.000	.077	2.659		.093		64.5	3.49	3.34	21315	7800
SHI-315	3.156	3-5/32	80.2	2.986		.103		.085	2.920	+.020	.093		77.0	3.82	3.66	23447	9400
SHI-325	3.250	3-1/4	82.5	3.076		.103		.087	3.006	-.030	.093		77.5	3.93	3.76	24056	10000
SHI-350	3.500	3-1/2	88.9	3.316		.120		.092	3.237		.109		107.0	4.22	4.04	30349	11500
SHI-393	3.938	3-15/16	100.0	3.734		.120		.102	3.642		.109		123.0	4.71	4.51	34206	14000

* F.I.M. (FULL INDICATOR MOVEMENT)-MAXIMUM ALLOWABLE DEVIATION OF CONCENTRICITY BETWEEN GROOVE AND SHAFT.
† BASED ON HOUSINGS/SHAFTS MADE OF COLD ROLLED STEEL. FOR AN EXPLANATION OF FORMULAS USED TO DERIVE THRUST LOAD AND OTHER PERFORMANCE DATA, CONTACT THE ROTOR CLIP ENGINEERING DEPARTMENT.
***FOR PLATED RINGS, ADD .002" TO THE LISTED MAXIMUM RING THICKNESS. MAXIMUM RING THICKNESS WILL BE A MINIMUM OF .0002" LESS THAN THE LISTED GROOVE WIDTH (W) MINIMUM.

HARDNESS RANGES: STAINLESS STEEL RINGS (PH 15-7MO)

RING TYPE	SIZE RANGE	SCALE	ROCKWELL HARDNESS
SHI	50-81	30N	63-69.5
	87+	C	44-51



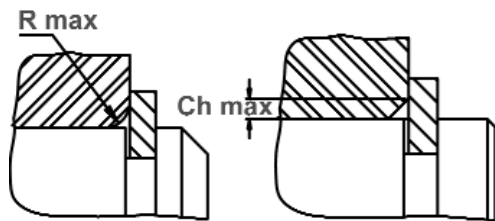

Maximum Corner Radius & Chamfer

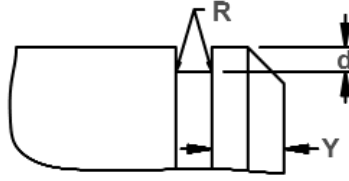

Exploded Groove Profile & Edge Margin (Y)
Maximum bottom radii (R), .005 for ring sizes -50 thru -100; .010 for ring sizes -106 thru -393

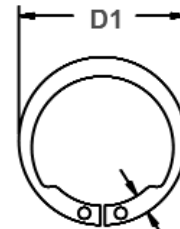

Measuring Free Diameter (Df) SHI Series
 $Df = D1 - 2(S \text{ max})$

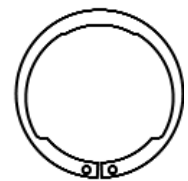

Alternate Design
Manufacturer's Option

RING NO.	MAXIMUM SECTION (Including Lug)		MINIMUM SECTION		HOLE DIAMETER		GAGING DIAMETER	ALLOWABLE CORNER RADII & CHAMFERS			MAX. LOAD w/R max or Ch max (in lbs.)	EDGE MARGIN	R.P.M. LIMITS Standard material
	S max	Tol.	S min	Tol.	R	Tol.		Gd Max	R max	Ch max			
SHI-50	.080		.041		.042		.64	.051	.032	680	.048	40000	
SHI-56	.088	±.004	.043	±.004	.042		.715	.057	.036	680	.048	35000	
SHI-59	.092		.046		.042		.75	.059	.037	680	.052	32000	
SHI-62	.096		.048		.042		.79	.062	.039	680	.055	30000	
SHI-68	.104		.052		.042	+ .010	.87	.066	.042	1000	.063	28000	
SHI-75	.112		.056		.042	- .002	.945	.071	.045	1000	.069	26500	
SHI-78	.116		.057		.042		.98	.073	.046	1000	.072	25500	
SHI-81	.120	±.005	.060	±.005	.050		1.02	.076	.048	1000	.075	24500	
SHI-87	.128		.064		.050		1.095	.080	.051	1000	.081	23000	
SHI-93	.136		.068		.050		1.17	.086	.054	1000	.084	21500	
SHI-100	.144		.072		.050		1.24	.091	.057	1000	.087	20000	
SHI-100	.144		.072		.050		1.25	.091	.057	1000	.090	20000	
SHI-106	.147		.073		.078		1.31	.092	.058	1460	.096	19000	
SHI-112	.150		.075		.078		1.38	.093	.059	1460	.099	18800	
SHI-118	.153		.076		.078		1.45	.094	.059	1460	.105	18000	
SHI-125	.157	±.006	.079	±.006	.078	+ .015	1.52	.096	.060	1460	.111	17000	
SHI-131	.161		.080		.078	- .002	1.58	.097	.061	1460	.120	16500	
SHI-137	.165		.082		.078		1.65	.098	.061	1460	.126	16000	
SHI-143	.169		.085		.078		1.715	.100	.063	1460	.132	15000	
SHI-150	.173		.086		.078		1.775	.100	.063	1460	.141	14800	
SHI-156	.178		.089		.078		1.85	.104	.066	2250	.141	14000	
SHI-162	.183		.092		.078		1.92	.108	.067	2250	.144	13200	
SHI-177	.196		.098		.078		2.07	.116	.073	2250	.150	11700	
SHI-177	.196		.098		.078		2.09	.116	.073	2250	.153	11700	
SHI-181	.199		.100		.078		2.13	.117	.074	2250	.156	11500	
SHI-196	.212		.106		.078		2.31	.124	.078	2250	.168	10500	
SHI-200	.216		.108		.078		2.35	.127	.080	2250	.171	10000	
SHI-215	.229		.117		.120		2.49	.133	.084	3750	.183	9400	
SHI-215	.229	±.007	.117	±.007	.120		2.52	.133	.084	3750	.186	9400	
SHI-250	.250		.130		.120		2.91	.151	.095	3750	.210	8400	
SHI-275	.280		.140		.120		3.19	.165	.103	5500	.222	7600	
SHI-287	.290		.145		.120		3.33	.170	.107	5500	.231	7300	
SHI-315	.316		.159		.120		3.65	.185	.116	5500	.255	6500	
SHI-325	.324	±.008	.162	±.008	.120		3.75	.190	.118	5500	.261	6400	
SHI-350	.345		.173		.125		4.03	.202	.127	7850	.276	5900	
SHI-393	.368		.183		.125		4.50	.212	.133	7850	.306	5200	

LARGER SIZES MAY BE AVAILABLE UPON REQUEST.

HARDNESS RANGES: CARBON STEEL RINGS (SAE 1060-1090)

RING TYPE	SIZE RANGE	SCALE	ROCKWELL HARDNESS
SHI	50-81	30N	66-71
	87-102	C	47-53
	106-343	C	47-52
	350+	C	45-50

HARDNESS RANGES: BERYLLIUM COPPER RINGS

RING TYPE	SIZE RANGE	SCALE	ROCKWELL HARDNESS
SHI	50-81	30N	56.5-62
	87+	C	37-43





SHR Shaft Rings

Axially Assembled, External Reinforced

The SHR is an extra thick version of a regular SH retaining ring.

As such, it is stronger and can withstand greater thrust loads than its standard counterpart.

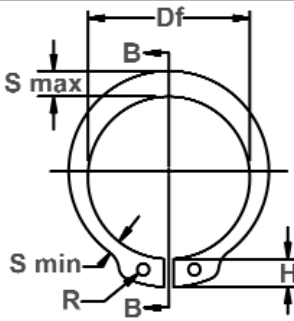

Free Diameter & Ring Measurements with Section B-B

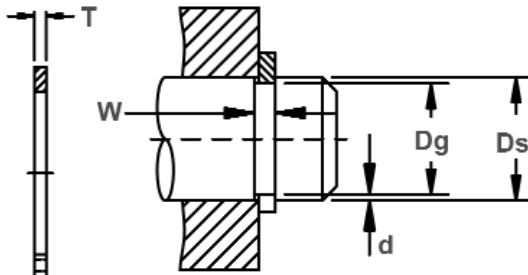

Shaft Diameter & Groove Dimensions

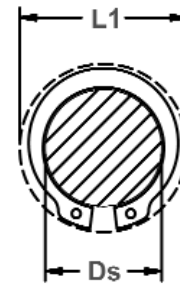

Clearance Diameter Expanded Over Shaft

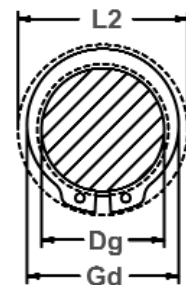

Clearance Diameter & Gaging Diameter Released in Groove

RING NO.	SHAFT DIAMETER			GROOVE SIZE			RING SIZE & WEIGHT				CLEAR. DIA.			THRUST LD. (lbs.)			
				DIAMETER		WIDTH	DEPTH	FREE DIAMETER		THICKNESS***		Weight Per 1000 pcs.	Expanded over shaft	Re-leased in groove	Sqr. corner abutment		
	Ds DEC	Ds FRAC	Ds mm	Dg	Tol.	W	Tol.	d	Df	Tol.	T				Tol.	L1	L2
SHR-39	.394	-	10.0	.368	+.001	.039		.013	.362	+.003	.035		.70	.61	.58	2030	700
SHR-42	.428	-	10.9	.402	-.002	.039	+.003	.013	.394	-.008	.035		.86	.65	.62	2335	800
SHR-47	.473	-	12.0	.444	.002*	.046	-.000	.015	.435		.042		1.4	.69	.66	3045	1000
SHR-50	.500	1/2	12.7	.468		.056		.016	.460		.050	±.002	1.6	.75	.72	3959	1100
SHR-59	.591	-	15.0	.555		.056	+.004	.018	.543		.050		2.2	.86	.83	4568	1500
SHR-62	.625	5/8	15.9	.588		.056	-.000	.019	.575		.050		2.3	.90	.86	4872	1600
SHR-66	.669	-	17.0	.629		.056		.020	.616	+.005	.050		2.6	.94	.90	5278	1900
SHR-75	.750	3/4	19.0	.704	+.001	.086		.023	.689	-.010	.078		5.6	1.12	1.08	9135	2400
SHR-75	.787	-	20.0	.740	-.003	.086		.024	.689		.078		5.6	1.16	1.12	9135	2400
SHR-87	.875	7/8	22.2	.821	.002*	.086		.027	.804		.078		7.5	1.25	1.20	10556	3300
SHR-98	.984	63/64	25.0	.925		.086		.030	.906		.078		7.8	1.36	1.30	11673	4000
SHR-98	1.000	1	25.4	.938		.086		.031	.906		.078		7.8	1.37	1.31	11673	4000
SHR-106	1.062	1-1/16	27.0	.998		.103		.032	.978		.093		11.5	1.52	1.46	15225	4800
SHR-112	1.125	1-1/8	28.6	1.059		.103	+.005	.033	1.036		.093	±.003	12.5	1.58	1.52	16240	5200
SHR-118	1.181	-	30.0	1.111		.103	-.000	.035	1.087	+.010	.093		13.5	1.64	1.57	16748	5600
SHR-118	1.188	1-3/16	30.2	1.111	+.002	.103		.038	1.087	-.015	.093		13.5	1.64	1.57	16748	5600
SHR-125	1.250	1-1/4	31.7	1.174	-.004	.103		.038	1.150		.093		14.9	1.70	1.63	17763	6500
SHR-131	1.312	1-5/16	33.3	1.234	.004*	.103		.039	1.208		.093		16.0	1.77	1.69	18270	7400
SHR-137	1.375	1-3/8	34.9	1.291		.103		.042	1.268		.093		17.8	1.83	1.75	19793	8200
SHR-137	1.378	-	35.0	1.291		.103		.044	1.268		.093		17.8	1.83	1.75	19793	8200
SHR-150	1.500	1-1/2	38.1	1.406		.120		.047	1.380		.109		27.0	2.08	1.98	24868	10000
SHR-156	1.562	1-9/16	39.7	1.468		.120		.047	1.437		.109		31.0	2.14	2.05	26390	10400
SHR-156	1.575	-	40.0	1.480		.120		.048	1.437		.109		31.0	2.15	2.06	26930	10400
SHR-175	1.750	1-3/4	44.4	1.650		.120		.050	1.608		.109		33.4	2.34	2.25	29435	12400
SHR-175	1.772	-	45.0	1.669	+.003	.120		.052	1.608	+.013	.109		33.4	2.37	2.27	29435	12400
SHR-193	1.938	1-15/16	49.2	1.826	-.004	.139		.056	1.782	-.020	.125	±.004	48.0	2.58	2.48	37555	15300
SHR-193	1.969	1-31/32	50.0	1.850	.004*	.139	+.006	.060	1.782		.125		48.0	2.61	2.50	37555	15300
SHR-200	2.000	2	50.8	1.880		.139	-.000	.060	1.840		.125		50.6	2.64	2.53	38570	17000

* F.I.M.(FULL INDICATOR MOVEMENT)-MAXIMUM ALLOWABLE DEVIATION OF CONCENTRICITY BETWEEN GROOVE AND SHAFT.

† BASED ON HOUSINGS/SHAFTS MADE OF COLD ROLLED STEEL. FOR AN EXPLANATION OF FORMULAS USED TO DERIVE THRUST LOAD AND OTHER PERFORMANCE DATA, CONTACT THE ROTOR CLIP ENGINEERING DEPARTMENT.

*** FOR PLATED RINGS, ADD .002" TO THE LISTED MAXIMUM THICKNESS. MAXIMUM RING THICKNESS WILL BE A MINIMUM OF .0002" LESS THAN THE LISTED GROOVE WIDTH (W) MINIMUM.

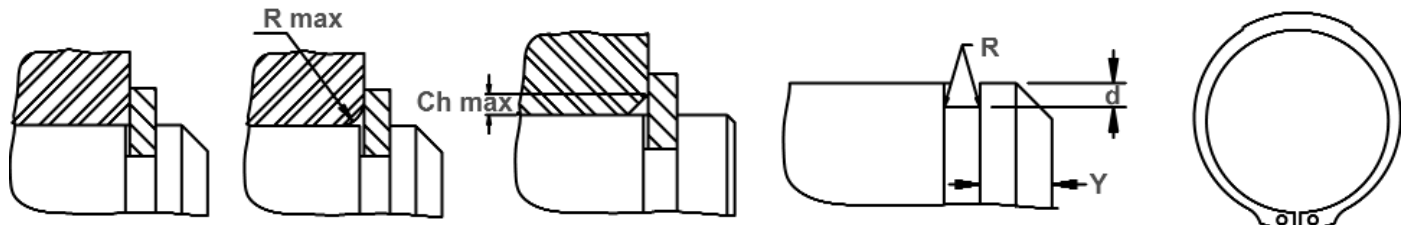

Square Corner Abutment

Maximum Corner Radius & Chamfer

Exploded Groove Profile & Edge Margin (Y) Maximum bottom radii (R), .005 for ring sizes -39 thru -98; .010 for ring sizes -106 thru -200

Alternate Design (Manufacturer's Option)

RING NO.	LUG HEIGHT		MAXIMUM SECTION		MINIMUM SECTION		HOLE DIAMETER		GAGING DIA.	ALLOWABLE CORNER RADII & CHAMFERS			MAX LOAD w/ R max or Ch max (in lbs.)	EDGE MARGIN	R.P.M. LIMITS Standard material			
	H	Tol.	S max	Tol.	S min	Tol.	R	Tol.		Gd Max	R max	Ch max				P'r	Y	
SHR-39	.101	±.004	.068	±.004	.039	±.004	.042	+.010	.479	.047	.039	450	.039	80000				
SHR-42	.101		.076		.043		.042		.525	.057	.046	530	.039	72000				
SHR-47	.101		.088		.053		.042		.589	.070	.058	550	.045	69000				
SHR-50	.120		.090		.050		.050		.613	.070	.058	650	.048	65000				
SHR-59	.130	±.005	.102	±.005	.057	±.005	.050	-.002	.719	.070	.058	750	.054	52500				
SHR-62	.130		.106		.059		.050		.758	.074	.062	750	.057	49000				
SHR-66	.130		.112		.062		.050		.808	.077	.064	900	.060	45000				
SHR-75	.180		.127		.077		.078		.913	.089	.074	2500	.069	40500				
SHR-75	.180	±.006	.127	±.006	.077	±.006	.078	+.015	.949	.089	.074	2500	.072	38000				
SHR-87	.180		.148		.083		.078		1.056	.100	.083	2500	.081	34000				
SHR-98	.180		.151		.084		.078		1.164	.100	.083	2500	.090	30000				
SHR-98	.180		.151		.084		.078		1.177	.100	.083	2500	.093	30000				
SHR-106	.220	±.005	.161	±.007	.090	±.007	.093	-.002	1.256	.106	.088	4000	.096	27000				
SHR-112	.220		.169		.095		.093		1.329	.112	.093	4000	.099	26000				
SHR-118	.220		.176		.098		.093		1.391	.112	.093	4000	.105	24000				
SHR-118	.220		.176		.098		.093		1.391	.112	.093	4000	.114	24000				
SHR-125	.220		.185		.103		.093		1.468	.112	.093	4000	.114	23000				
SHR-131	.220		.192		.106		.093		1.538	.128	.107	4000	.117	21500				
SHR-137	.220		.200		.110		.093		1.607	.128	.107	4000	.126	20500				
SHR-137	.220		.200		.110		.093		1.607	.128	.107	4000	.132	20500				
SHR-150	.280		±.008		.218		±.008		.123	±.008	.109	+.015	1.752	.128	.107	5000	.141	18500
SHR-156	.280				.228				.127		.109		1.829	.128	.107	5000	.141	17000
SHR-156	.280	.228		.127	.109	1.841		.128	.107		5000		.144	17000				
SHR-175	.290	.254		.140	.109	2.050		.128	.107		5000		.150	15500				
SHR-175	.290	.254		.140	.109	2.069		.128	.107		5000		.156	15500				
SHR-193	.314	±.006		.280	±.006	.154		±.006	.125		-.002		2.265	.153	.128	6000	.168	14300
SHR-193	.314		.280	.154		.125	2.289		.153	.128		6000	.180	14100				
SHR-200	.314		.290	.160		.125	2.334		.153	.128		6000	.180	14000				

LARGER SIZES MAY BE AVAILABLE UPON REQUEST.

HARDNESS RANGES: STAINLESS STEEL RINGS (PH 15-7M0)

RING TYPE	SIZE RANGE	SCALE	ROCKWELL HARDNESS
SHR	39-42	30N	63-69.5
	47+	C	44-51

HARDNESS RANGES: BERYLLIUM COPPER RINGS

RING TYPE	SIZE RANGE	SCALE	ROCKWELL HARDNESS
SHR	39-42	30N	54-62
	47+	C	34-43

HARDNESS RANGES: CARBON STEEL RINGS (SAE 1060-1090)

RING TYPE	SIZE RANGE	SCALE	ROCKWELL HARDNESS
SHR	39-62	30N	67.5-72
	66+	C	47-52



SHM Shaft Rings

Axially Assembled, External Tamper-Proof

The SHM also functions like an SH retaining ring, but in "smaller" applications. It is also a tamper proof ring which does not have any lugs and can not be easily removed once installed.

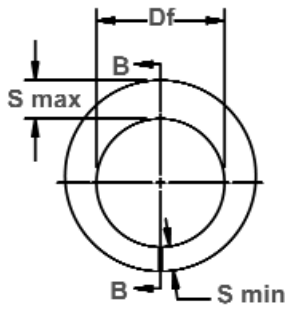

Free Diameter & Ring Measurements with Section B-B

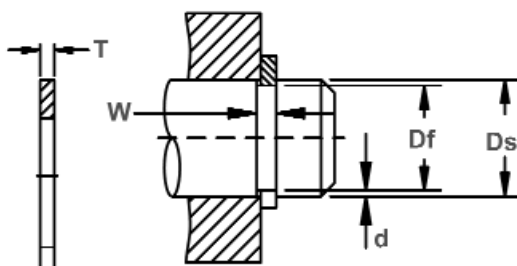

Shaft Diameter & Groove Dimensions

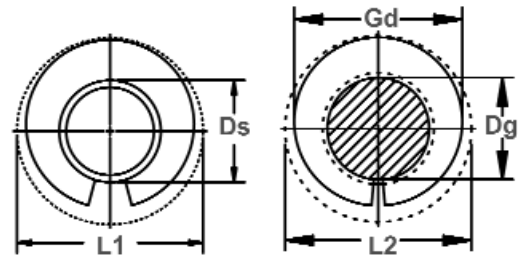

Clearance Diameter & Gaging Diameter

RING NO.	SHAFT DIAMETER inches			GROOVE SIZE					RING SIZE & WEIGHT				CLEARANCE DIA.			i THRUST LD. (lbs.) Sqr. Corner Abutment Groove w/90° wall	
				DIAMETER		WIDTH		DEPTH	FREE DIAMETER		THICKNESS***		Weight Per 1000 Pcs.	Expanded over shaft	Re-released in groove	Ring Safety Factor of 4	Groove Safety Factor of 2
	Ds DEC	Tol.	Ds FRACT	Dg	Tol.	W	Tol.	d	Df	Tol.	T	Tol.					
SHM-10	.101		-	.093	±.001	.024		.004	.090		.020		.036	.160	.152		30
SHM-12	.125	±.001	1/8	.115	.0015*	.024	+ .002	.005	.112		.020		.050	.186	.176		40
SHM-13	.134		-	.124		.024	- .000	.005	.120	±.002	.020		.059	.197	.187		45
SHM-15	.156		5/32	.144		.029		.006	.140		.025		.122	.252	.240	**	65
SHM-18	.188		3/16	.174		.029		.007	.168		.025		.179	.297	.283	SEE NOTE	90
SHM-20	.203		13/64	.189		.029		.007	.180		.025	±.002	.167	.302	.288	BELOW	100
SHM-22	.219		7/32	.205		.039		.007	.200	±.003	.035	±.002	.334	.345	.331	**	110
SHM-25	.250		1/4	.232	±.0015	.039		.009	.224		.035		.386	.384	.366		160
SHM-26	.266		17/64	.248	+ .002*	.039	+ .003	.009	.240		.035		.467	.406	.388		170
SHM-31	.312	±.0015	5/16	.292		.039	- .000	.010	.284		.035		.626	.478	.458		220
SHM-32	.328		21/64	.308		.039		.010	.300		.035		.688	.498	.480		230
SHM-37	.375		3/8	.351	±.002.002*	.046		.012	.340		.042		1.035	.567	.543		315

*F.I.M. (FULL INDICATOR MOVEMENT)-MAXIMUM ALLOWABLE DEVIATION OF CONCENTRICITY BETWEEN GROOVE AND SHAFT.

i BASED ON HOUSINGS/SHAFTS MADE OF COLD ROLLED STEEL. FOR AN EXPLANATION OF FORMULAS USED TO DERIVE THRUST LOAD AND OTHER PERFORMANCE DATA, CONTACT THE ROTOR CLIP ENGINEERING DEPT.

***FOR PLATED RINGS, ADD .002" TO THE LISTED MAXIMUM THICKNESS. MAXIMUM RING THICKNESS WILL BE A MINIMUM OF .0002" LESS THAN THE LISTED GROOVE WIDTH (W) MINIMUM.

**CALL FOR INFORMATION:1-800-557-6867 (+1 732-469-7333)

INSTALLATION OF ROTOR CLIP SHM RINGS

Rotor Clip SHM retaining rings can be installed by means of a tapered mandrel and a bushing. The mandrel can be eliminated in applications where the shaft can be easily tapered, as illustrated below.

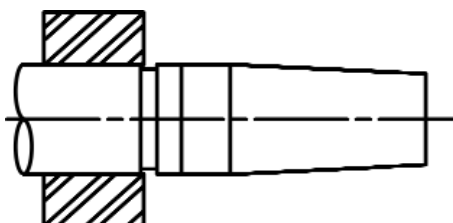

To install, place ring on mandrel and position bushing as shown. Ring can be pushed or tapped into groove.

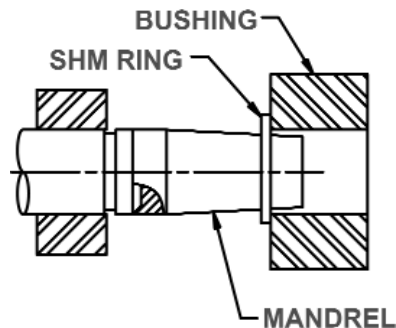

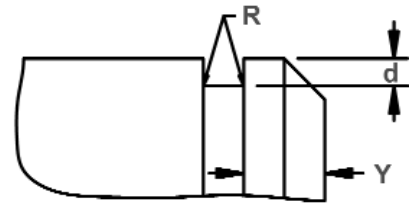
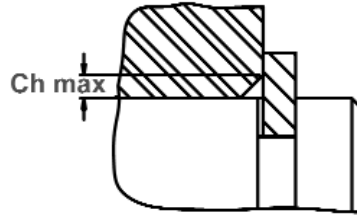
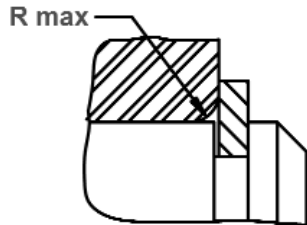

Maximum Corner Radius & Chamfer

Exploded Groove Profile & Edge Margin (Y)
Maximum bottom radii (R). Sharp corners-
no radii for ring sizes -10 thru -37.

RING NO.	S Max.	S Min.	GAGING DIA.	ALLOWABLE CORNER RADII &		MAX. LOAD w/ R max or Ch max. (in lbs.)	EDGE MARGIN	R.P.M. LIMITS Standard material	RING NO.	MANDREL					BUSHING		
	Ref.	Ref.		Gd Max	R max					Ch max	i P'r (lbs.)	Y	Dp	Tol.	W ref.	G	Tol.
SHM-10	.027	.017	.143	.013	.010	SEE NOTE ON PREVIOUS PAGE	.012	80000	SHM-10	.102	+.000 -.0015	.036	.750	±.005	.104	+.002	3/8
SHM-12	.028	.018	.167	.013	.010		.015	80000	SHM-12	.126		.059	.750		.128		3/8
SHM-13	.029	.019	.178	.014	.011		.015	80000	SHM-13	.135		.069	.750		.137		3/8
SHM-15	.045	.027	.222	.021	.017		.018	80000	SHM-15	.157		.078	.875		.159		1/2
SHM-18	.052	.032	.264	.024	.019		.021	80000	SHM-18	.189		.110	.875		.191		1/2
SHM-20	.046	.030	.272	.023	.018		.021	80000	SHM-20	.204		.125	.875		.206		1/2
SHM-22	.058	.036	.308	.028	.022		.021	80000	SHM-22	.221		.129	1.000		.223		1/2
SHM-25	.063	.037	.340	.028	.022		.027	80000	SHM-25	.252		.101	1.000		.254		5/8
SHM-26	.065	.037	.359	.027	.022		.027	80000	SHM-26	.268		.176	1.000		.270		5/8
SHM-31	.078	.050	.431	.038	.030		.030	80000	SHM-31	.314		.223	1.000		.316		5/8
SHM-32	.080	.050	.448	.038	.030		.030	80000	SHM-32	.330		.238	1.000		.332		5/8
SHM-37	.090	.058	.511	.042	.033		.036	80000	SHM-37	.377		.286	1.000		.379		5/8

LARGER SIZES MAY BE AVAILABLE UPON REQUEST.

HARDNESS RANGES: STAINLESS STEEL RINGS (PH 15-7MO)

RING TYPE	SIZE RANGE	SCALE	ROCKWELL HARDNESS
SHM	10-15	15N	82.5-86.0*
	18+	30N	63.0-69.5

*HARDNESS CAN NOT BE CHECKED WITH ANY DEGREE OF ACCURACY DIRECTLY ON THESE RINGS.

HARDNESS RANGES: BERYLLIUM COPPER RINGS

RING TYPE	SIZE RANGE	SCALE	ROCKWELL HARDNESS
SHM	10-15	15N	77.0-82.0*
	18+	30N	54-62

*HARDNESS CAN NOT BE CHECKED WITH ANY DEGREE OF ACCURACY DIRECTLY ON THESE RINGS.

HARDNESS RANGES: CARBON STEEL RINGS (SAE 1060-1090)

RING TYPE	SIZE RANGE	SCALE	ROCKWELL HARDNESS
SHM	10-15	15N	85.5-87.4*
	18+	30N	68.5-72

*HARDNESS CAN NOT BE CHECKED WITH ANY DEGREE OF ACCURACY DIRECTLY ON THESE RINGS.

PRODUCTION OF MANDREL AND BUSHING

Specifications for the production of a mandrel and bushing for installing SHM rings are listed in the above charts. Recommended material is high carbon spring steel, heat treated.

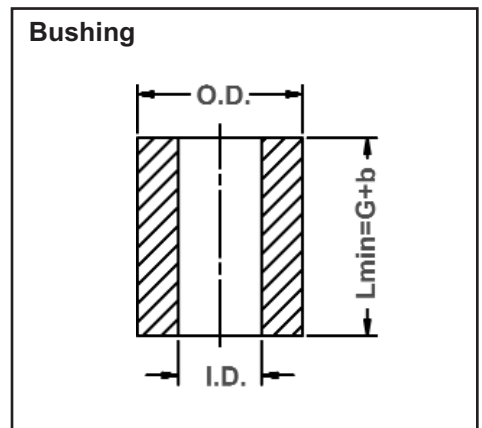
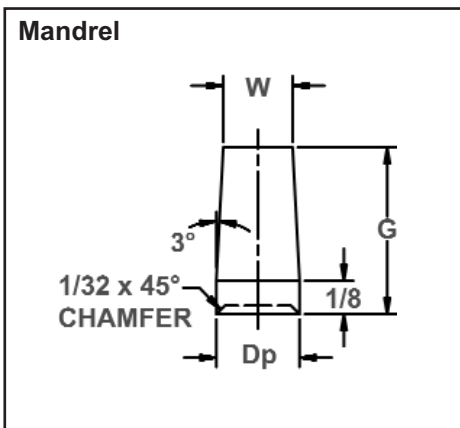
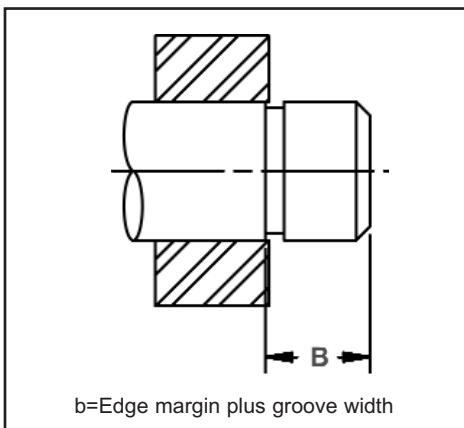



BHO Housing Rings

Axially Assembled, Internal Bowed

Compensating for accumulated tolerances is what a BHO retaining ring is designed to do in a housing/bore. Once snapped into the groove, bowed rings exert a force or "preload" on the retained parts for the range specified.

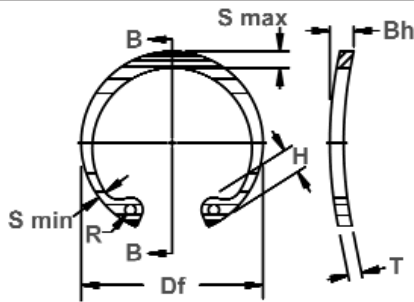

Free Diameter & Ring Measurements with Section B-B

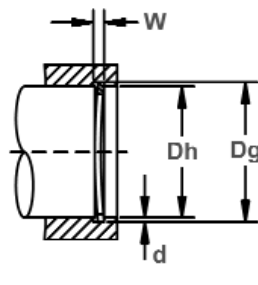

Housing Diameter & Groove Dimensions

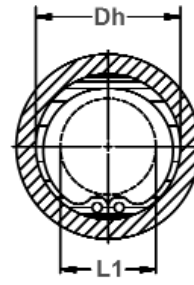

Clearance Diameter Compressed in Housing

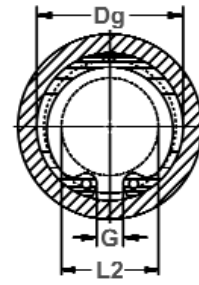

Clearance Diameter & Gap Width Released in Groove

RING NO.	HOUSING DIAMETER			GROOVE SIZE			RING SIZE & WEIGHT				CLEAR.DIA.			THRUST LD. (lbs.)					
				DIAMETER		WIDTH	DEPTH	FREE DIAMETER	THICKNESS***		BOW HEIGHT	Weight Per 1000 Pcs.	Compressed in housing	Re-released in groove	Sqr. Corner Abutment				
	Dh DEC	Dh FRACT	Dh mm	Dg	Tol.	W	Tol.	d	Df	Tol.	T	Tol.	Bh	Tol.	lbs.	L1	L2	Pr	Pg
BHO-25	.250	1/4	6.4	.268	±.001	.030	+.002	.009	.280		.015		.036		.08	.115	.133	426	190
BHO-31	.312	5/16	7.9	.330	.0015*	.030	-.000	.009	.346		.015		.036		.11	.173	.191	538	240
BHO-37	.375	3/8	9.5	.397		.040		.011	.415		.025		.047		.25	.204	.226	1066	350
BHO-43	.438	7/16	11.1	.461	±.002	.040		.012	.482	±.010	.025		.047	±.006	.37	.23	.254	1238	440
BHO-45	.453	29/64	11.5	.477	.002*	.040		.012	.498		.025		.047		.43	.25	.274	1299	460
BHO-50	.500	1/2	12.7	.530		.055		.015	.548		.035		.063		.70	.26	.29	2010	510
BHO-51	.512	-	13.0	.542	±.002	.055	+.003	.015	.560		.035		.063	±.007	.77	.27	.30	2060	520
BHO-56	.562	9/16	14.3	.596	.004*	.055	-.000	.017	.620		.035		.063		.86	.275	.305	2253	710
BHO-62	.625	5/8	15.9	.665		.055		.020	.694		.035		.063		1.0	.34	.38	2507	1050
BHO-68	.688	11/16	17.5	.732		.055		.022	.763		.035		.063		1.2	.40	.44	2741	1280
BHO-75	.750	3/4	19.0	.796		.055		.023	.831		.035		.063		1.3	.45	.49	3045	1460
BHO-77	.777	-	19.7	.825		.062		.024	.859		.042		.073		1.7	.475	.52	4618	1580
BHO-81	.812	13/16	20.6	.862		.062		.025	.901		.042		.073		1.9	.49	.54	4872	1710
BHO-86	.866	-	22.0	.920		.062		.027	.961		.042		.073		2.0	.54	.59	5177	1980
BHO-87	.875	7/8	22.2	.931		.062		.028	.971		.042		.073		2.1	.545	.60	5227	2080
BHO-90	.901	-	22.9	.959	±.003	.062		.029	1.000	±.015	.042	±.002	.073	±.008	2.2	.565	.62	5430	2200
BHO-93	.938	15/16	23.8	1.000	.004*	.062		.031	1.041		.042		.073		2.4	.61	.67	5684	2450
BHO-100	1.000	1	25.4	1.066		.062		.033	1.111		.042		.073		2.7	.665	.73	6039	2800
BHO-102	1.023	-	26.0	1.091		.062		.034	1.136		.042		.073		2.8	.69	.755	6141	3000
BHO-106	1.062	1-1/16	27.0	1.130		.070		.034	1.180		.050		.085		3.7	.685	.75	7562	3050
BHO-112	1.125	1-1/8	28.6	1.197		.070		.036	1.249		.050		.085		4.0	.745	.815	8019	3400
BHO-118	1.181	-	30.0	1.255		.070		.037	1.319		.050		.085		4.3	.79	.86	8526	3700
BHO-118	1.188	1-3/16	30.2	1.262		.070		.037	1.319		.050		.085		4.3	.80	.87	8526	3700
BHO-125	1.250	1-1/4	31.7	1.330	±.004	.070		.040	1.388	±.025	.050		.085	±.012	4.8	.875	.955	8932	4250
BHO-125	1.259	-	32.0	1.339	.005*	.070		.040	1.388		.050		.085		4.8	.885	.965	8932	4250
BHO-131	1.312	1-5/16	33.3	1.396		.070		.042	1.456		.050		.085		5.0	.93	1.01	9440	4700
BHO-137	1.375	1-3/8	34.9	1.461		.070		.043	1.526		.050		.085		5.1	.99	1.07	9846	5050
BHO-137	1.378	-	35.0	1.464		.070		.043	1.526		.050		.085		5.1	.99	1.07	9846	5050
BHO-143	1.438	1-7/16	36.5	1.528		.070		.045	1.596		.050		.085		5.8	1.06	1.15	10353	5500
BHO-145	1.456	-	37.0	1.548		.070		.046	1.616		.050		.085		6.4	1.08	1.17	10455	5700
BHO-150	1.500	1-1/2	38.1	1.594		.070		.047	1.660		.050		.085		6.5	1.12	1.21	10708	6000
BHO-156	1.562	1-9/16	39.7	1.658		.100		.048	1.734		.062		.115		8.9	1.14	1.23	13906	6350
BHO-156	1.575	-	40.0	1.671	±.005	.100	+.005	.048	1.734	+.035	.062	±.003	.115	±.015	8.9	1.15	1.24	13906	6350
BHO-162	1.625	1-5/8	41.3	1.725	.005*	.100	-.000	.050	1.804	-.025	.062		.115		10.0	1.15	1.25	14413	6900
BHO-175	1.750	1-3/4	44.4	1.858		.100		.054	1.942		.062		.115		10.3	1.26	1.36	15580	8050

*F.I.M. (FULL INDICATOR MOVEMENT)-MAXIMUM ALLOWABLE DEVIATION OF CONCENTRICITY BETWEEN GROOVE AND HOUSING.

† BASED ON HOUSINGS/SHAFTS MADE OF COLD ROLLED STEEL. FOR AN EXPLANATION OF FORMULAS USED TO DERIVE THRUST LOAD AND OTHER PERFORMANCE DATA, CONTACT THE ROTOR CLIP ENGINEERING DEPT.

*** FOR PLATED RINGS, ADD .002" TO THE LISTED MAXIMUM THICKNESS.

HARDNESS RANGES: STAINLESS STEEL RINGS (PH 15-7MO)

RING TYPE	SIZE RANGE	SCALE	ROCKWELL HARDNESS
BHO	25&31	15N	82.5-86
	37-102	30N	63-69.5
	106+	C	44-51



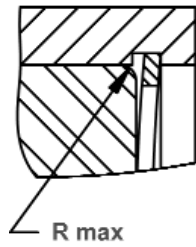

R max

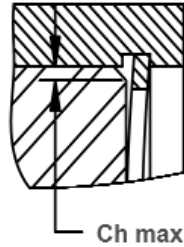

Ch max

Maximum Corner Radius & Chamfer

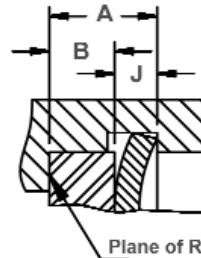

Plane of Reference

Outer Groove Location
 $A \max = B \min + J \max$
 $A \min = B \max + J \min$

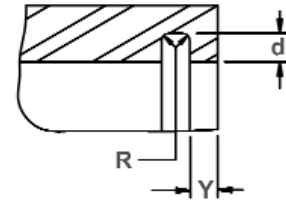

Exploded Groove Profile & Edge Margin (Y)
 Maximum bottom radii (R), .005 for ring sizes -25 thru -100; .010 for ring sizes -102 and over

RING NO.	DISTANCE Outer groove wall to face of retained part		TAKE UP Resilient take up of tolerances of A&B	FORCE Needed to flatten rings	ALLOWABLE CORNER RADII & CHAMFERS		MAX LOAD w/ R max or Ch max (in lbs.)	EDGE MARGIN Y	LUG HEIGHT H	MAXIMUM SECTION	MINIMUM SECTION	HOLE DIAMETER		GAP WIDTH Ring in groove		
	J min	J max			J max - J min	R max						Ch max	S max		Tol.	S min
BHO-25	.020	.028	.008	20	.011	.0085	190	.027	.065	±.003	.025	±.002	.015	±.002	.031	.047
BHO-31	.020	.028			.016	.013		190	.027		.066	.033	.018	.031	.055	
BHO-37	.030	.038			.023	.018		530	.033		.082	.040	.028	.041	.063	
BHO-43	.030	.038			.027	.021		530	.036		.098	.049	.029	.041	.063	
BHO-45	.030	.038			.027	.021		530	.036		.098	.050	.030	.047	.071	
BHO-50	.042	.053			.027	.021		1100	.045		.114	.053	.035	.047	.090	
BHO-51	.042	.053			.027	.021		1100	.045		.114	.053	.035	.047	.092	
BHO-56	.042	.053			.027	.021		1100	.051		.132	.053	.035	.047	.095	
BHO-62	.042	.053			.027	.021		1100	.060		.132	.060	.035	.062	.104	
BHO-68	.042	.053			.027	.021		1100	.066		.132	.063	.036	.062	.118	
BHO-75	.042	.053	.032	.025	1100	.069	.142	.070	.040	.062	.143					
BHO-77	.049	.060	.035	.028	1650	.072	.146	.074	.044	.062	.145					
BHO-81	.049	.060	.035	.028	1650	.075	.155	.077	.044	.062	.153					
BHO-86	.049	.060	.035	.028	1650	.081	.155	.081	.045	.062	.172					
BHO-87	.049	.060	.035	.028	1650	.084	.155	.084	.045	.062	.179					
BHO-90	.049	.060	.038	.030	1650	.087	.155	.087	.047	.062	.188					
BHO-93	.049	.060	.038	.030	1650	.093	.155	.091	.050	.062	.200					
BHO-100	.049	.060	.042	.034	1650	.099	.155	.104	.052	.062	.212					
BHO-102	.049	.060	.042	.034	1650	.102	.155	.106	.054	.062	.220					
BHO-106	.057	.068	.044	.035	2400	.102	.180	.110	.055	.078	.213					
BHO-112	.057	.068	.047	.036	2400	.108	.180	.116	.057	.078	.232					
BHO-118	.057	.068	.047	.036	2400	.111	.180	.120	.058	.078	.226					
BHO-118	.057	.068	.047	.036	2400	.111	.180	.120	.058	.078	.245					
BHO-125	.057	.068	.048	.038	2400	.120	.180	.124	.062	.078	.265					
BHO-125	.057	.068	.048	.038	2400	.120	.180	.124	.062	.078	.290					
BHO-131	.057	.068	.048	.038	2400	.126	.180	.130	.062	.078	.284					
BHO-137	.057	.068	.048	.038	2400	.129	.180	.130	.063	.078	.297					
BHO-137	.057	.068	.048	.038	2400	.129	.180	.130	.063	.078	.305					
BHO-143	.057	.068	.048	.038	2400	.135	.180	.133	.065	.078	.313					
BHO-145	.057	.068	.048	.038	2400	.138	.180	.133	.065	.078	.320					
BHO-150	.057	.068	.048	.038	2400	.141	.180	.133	.066	.078	.340					
BHO-156	.075	.095	.064	.050	3900	.144	.202	.157	.078	.078	.338					
BHO-156	.075	.095	.064	.050	3900	.144	.202	.157	.078	.078	.374					
BHO-162	.075	.095	.064	.050	3900	.150	.227	.164	.082	.078	.339					
BHO-175	.075	.095	.064	.050	3900	.162	.234	.171	.083	.078	.372					

LARGER SIZES MAY BE AVAILABLE UPON REQUEST.

HARDNESS RANGES: CARBON STEEL RINGS (SAE 1060-1090)

RING TYPE	SIZE RANGE	SCALE	ROCKWELL HARDNESS
BHO	25&31	15N	86-88
	37-51	30N	69.5-73
	56-77	30N	67.5-72
	81-102	30N	66-71
	106+	C	47-52

HARDNESS RANGES: BERYLLIUM COPPER RINGS

RING TYPE	SIZE RANGE	SCALE	ROCKWELL HARDNESS
BHO	25&31	15N	77-82
	37-102	30N	54-62
	106+	C	34-43





BSH Shaft Rings

Axially Assembled, External Bowed

Compensating for accumulated tolerances is what a BSH "bowed" retaining ring is designed to do on a shaft. Once snapped into the groove, bowed rings exert a force or a "preload" on the retained parts for the range specified.

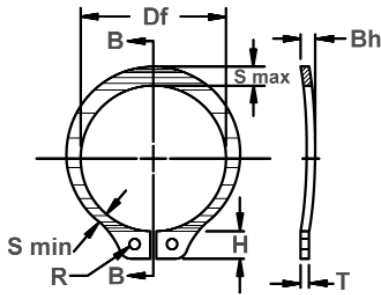

Free Diameter & Ring Measurements with Section B-B

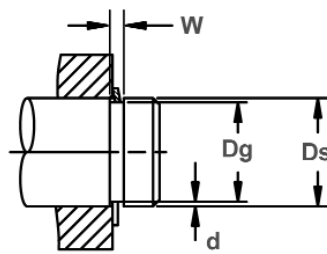

Shaft Diameter & Groove Dimensions

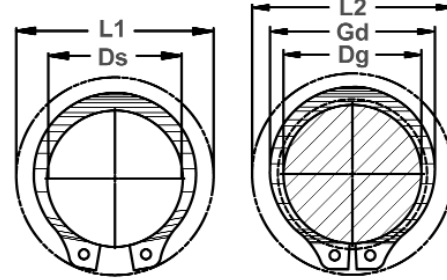

Clearance Diameter & Gaging Diameter

RING NO.	SHAFT DIAMETER			GROOVE SIZE			RING SIZE & WEIGHT					CLEAR. DIA.			THRUST LD. (lbs.)		
				Dg	DIAMETER		W	DEPTH	FREE DIAMETER		THICKNESS ***		BOW HEIGHT	Wght. Per 1000 Pcs.	Ex-panded over shaft	Re-leased in groove	Sqr. Corner Abutment
	Tol.	Tol.	d		Df	Tol.			T	Tol.	Bh	Tol.					
BSH-25	.250	1/4	6.4	.230	±.0015	.040	.010	.225	+.002	-.004	.025	.047	.21	.45	.43	599	175
BSH-27	.276	-	7.0	.255		.040	.010	.250			.025	.047	.23	.48	.46	660	195
BSH-28	.281	9/32	7.1	.261		.040	.010	.256			.025	.047	.24	.49	.47	670	200
BSH-31	.312	5/16	7.9	.290		.040	.011	.281			.025	.047	.27	.54	.52	751	240
BSH-34	.344	11/32	8.7	.321		.040	.011	.309			.025	.047	.31	.57	.55	812	265
BSH-35	.354	-	9.0	.330	±.002	.040	.012	.320	+.002		.025	.047	.35	.59	.57	832	300
BSH-37	.375	3/8	9.5	.352	.002*	.040	.012	.338	-.005		.025	.047	.39	.61	.59	883	325
BSH-39	.394	-	10.0	.369		.040	.012	.354			.025	.047	.42	.62	.60	954	335
BSH-40	.406	13/32	10.3	.382		.040	.012	.366			.025	.047	.43	.63	.61	964	350
BSH-43	.438	7/16	11.1	.412		.040	.013	.395			.025	.047	.50	.66	.64	1035	400
BSH-46	.469	15/32	11.9	.443		.040	.013	.428			.025	.047	.54	.68	.66	1117	450
BSH-50	.500	1/2	12.7	.468	±.002	.055	.016	.461			.035	.063	.91	.77	.74	1675	550
BSH-55	.551	-	14.0	.519	.004*	.055	.016	.509			.035	.063	.90	.81	.78	1827	600
BSH-56	.562	9/16	14.3	.530		.055	.016	.521			.035	.063	1.1	.82	.79	1878	650
BSH-59	.594	19/32	15.1	.559		.055	.017	.550	±.002		.035	.063	1.2	.86	.83	1979	750
BSH-62	.625	5/8	15.9	.588		.055	.018	.579			.035	.063	1.3	.90	.87	2091	800
BSH-66	.669	-	17.0	.629		.055	.020	.621	±.003		.035	.063	1.4	.93	.89	2233	950
BSH-66	.672	43/64	17.1	.631		.055	.020	.621	-.000		.035	.063	1.4	.93	.89	2233	950
BSH-68	.688	11/16	17.5	.646	±.003	.062	.021	.635	+.005		.042	.073	1.8	1.01	.97	3451	1000
BSH-75	.750	3/4	19.0	.704	.004*	.062	.023	.693	-.010		.042	.073	2.1	1.09	1.05	3756	1200
BSH-78	.781	25/32	19.8	.733		.062	.024	.722			.042	.073	2.2	1.12	1.08	3959	1300
BSH-81	.812	13/16	20.6	.762		.062	.025	.751			.042	.073	2.5	1.15	1.10	4060	1450
BSH-87	.875	7/8	22.2	.821		.062	.027	.810			.042	.073	2.8	1.21	1.16	4365	1650
BSH-93	.938	15/16	23.8	.882		.062	.028	.867			.042	.073	3.1	1.34	1.29	4720	1850
BSH-98	.984	63/64	25.0	.926		.062	.029	.910			.042	.073	3.5	1.39	1.34	4923	2000
BSH-100	1.000	1	25.4	.940		.062	.030	.925			.042	.073	3.6	1.41	1.35	5024	2100
BSH-102	1.023	-	26.0	.961		.062	.031	.946			.042	.073	3.9	1.43	1.37	5126	2250
BSH-106	1.062	1-1/16	27.0	.998		.070	.032	.982			.050	.085	4.8	1.50	1.44	6293	2400
BSH-112	1.125	1-1/8	28.6	1.059		.070	.033	1.041			.050	.085	5.1	1.55	1.49	6699	2600
BSH-118	1.188	1-3/16	30.2	1.118		.070	.035	1.098			.050	.085	5.6	1.61	1.54	7105	2950
BSH-125	1.250	1-1/4	31.7	1.176	±.004	.070	.037	1.156	+.010		.050	.085	5.9	1.69	1.62	7460	3250
BSH-131	1.312	1-5/16	33.3	1.232	.005*	.070	.040	1.214	-.015		.050	.085	6.8	1.75	1.67	7866	3700
BSH-137	1.375	1-3/8	34.9	1.291		.070	.042	1.272			.050	.085	7.2	1.80	1.72	8222	4100
BSH-143	1.438	1-7/16	36.5	1.350		.070	.044	1.333			.050	.085	8.1	1.87	1.79	8628	4500
BSH-150	1.500	1-1/2	38.1	1.406		.070	.047	1.387			.050	.085	9.0	1.99	1.90	8932	5000
BSH-162	1.625	1-5/8	41.3	1.529	±.005	.096	+.005	.048	1.503	+.013	.062	±.003	.115	±.015		12028	5500
BSH-175	1.750	1-3/4	44.4	1.650	.005*	.096	-.000	.050	1.618	-.020	.062		15.3	2.31	2.21	12992	6200

*F.I.M. (FULL INDICATOR MOVEMENT)-MAXIMUM ALLOWABLE DEVIATION OF CONCENTRICITY BETWEEN GROOVE AND SHAFT.

† BASED ON HOUSINGS/SHAFTS MADE OF COLD ROLLED STEEL. FOR AN EXPLANATION OF FORMULAS USED TO DERIVE THRUST LOAD AND OTHER PERFORMANCE DATA, CONTACT THE ROTOR CLIP ENGINEERING DEPT.

***FOR PLATED RINGS, ADD .002" TO THE LISTED MAXIMUM THICKNESS.

HARDNESS RANGES: STAINLESS STEEL RINGS (PH 15-7MO)

RING TYPE	SIZE RANGE	SCALE	ROCKWELL HARDNESS
BSH	25-81	30N	63-69.5
	87+	C	44-51



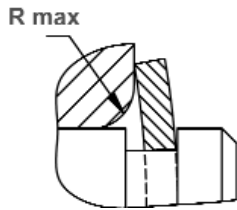

Maximum Corner Radius & Chamfer

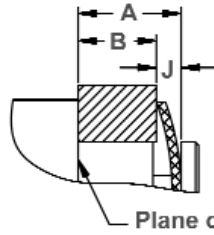
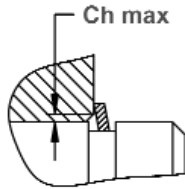

Outer Groove Location
 $A \text{ max} = B \text{ min} + J \text{ max}$
 $A \text{ min} = B \text{ max} + J \text{ min}$

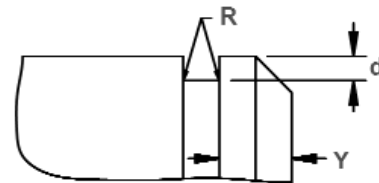

Exploded Groove Profile & Edge Margin (Y) Maximum bottom radii (R), square corners For ring sizes -25 thru -35; .005 For ring sizes -37 thru -100; .010 For ring sizes -102 and over.

RING NO.	DISTANCE Outer groove wall to face of retained part		TAKE-UP Resilient take-up of tolerances J max J min	FORCE Needed to flatten rings lbs.	ALLOWABLE CORNER RADII & CHAMFERS		MAX. LOAD w/ R max or Ch max (in lbs.) Pr (lbs.)	EDGE MARGIN Y	LUG HEIGHT H Tol.	MAXIMUM SECTION		MINIMUM SECTION		HOLE DIAMETER		GAGING DIA. Gd Max	R.P.M LIMITS Standard material	
	J min	J max			R max	Ch max				S max	Tol.	S min	Tol.	R	Tol.			
BSH-25	.030	.038	.008	50	.018	.011	470	.030	.080	±.003	.035	±.003	.025	±.003	.041	+.010 -.002	.290	80000
BSH-27	.030	.038		50	.0175	.0105	470	.031	.081		.035		.024		.041		.315	76000
BSH-28	.030	.038		50	.020	.012	470	.030	.080		.038		.0255		.041		.326	74000
BSH-31	.030	.038		50	.020	.012	470	.033	.087		.040		.026		.041		.357	70000
BSH-34	.030	.038		45	.021	.0125	470	.033	.087		.042		.0265		.041		.390	64000
BSH-35	.030	.038		45	.023	.014	470	.036	.087		.046		.029		.041		.405	62000
BSH-37	.030	.038		45	.026	.0155	470	.036	.088		.050		.0305		.041		.433	60000
BSH-39	.030	.038		40	.027	.016	470	.037	.087		.052		.031		.041		.452	56500
BSH-40	.030	.038		40	.0285	.017	470	.036	.087		.054		.033		.041		.468	55000
BSH-43	.030	.038		35	.029	.0175	470	.039	.088		.055		.033		.041		.501	50000
BSH-46	.030	.038	35	.031	.018	470	.039	.088	.060	.035	.041	.540	42000					
BSH-50	.042	.053	.011	90	.034	.020	910	.048	.108	±.004	.065	±.004	.040	±.004	.047	+.015 -.002	.574	40000
BSH-55	.042	.053		85	.027	.0165	910	.048	.108		.053		.036		.047		.611	36000
BSH-56	.042	.053		80	.038	.023	910	.048	.108		.072		.041		.047		.644	35000
BSH-59	.042	.053		70	.0395	.0235	910	.052	.109		.076		.043		.047		.680	32000
BSH-62	.042	.053		60	.0415	.025	910	.055	.110		.080		.045		.047		.715	30000
BSH-66	.042	.053		50	.040	.024	910	.060	.110		.082		.043		.047		.756	29000
BSH-66	.042	.053		50	.040	.024	910	.060	.110		.082		.043		.047		.758	29000
BSH-68	.049	.060		70	.042	.025	1340	.063	.136		.084		.048		.052		.779	28000
BSH-75	.049	.060		65	.046	.0275	1340	.069	.136		.092		.051		.052		.850	26500
BSH-78	.049	.060		60	.047	.028	1340	.072	.136		.094		.052		.052		.883	25500
BSH-81	.049	.060	55	.047	.028	1340	.075	.136	.096	.054	.052	.914	24500					
BSH-87	.049	.060	45	.051	.035	1340	.081	.137	.104	.057	.052	.987	23000					
BSH-93	.049	.060	40	.055	.033	1340	.084	.166	.110	.063	.078	1.054	21500					
BSH-98	.049	.060	40	.056	.0335	1340	.087	.167	.114	.0645	.078	1.106	20500					
BSH-100	.049	.060	35	.057	.034	1340	.090	.167	.116	.065	.078	1.122	20000					
BSH-102	.049	.060	35	.058	.035	1340	.093	.168	.118	.066	.078	1.147	19500					
BSH-106	.057	.068	60	.060	.036	1950	.096	.181	.122	.069	.078	1.192	19000					
BSH-112	.057	.068	55	.063	.038	1950	.099	.182	.128	.071	.078	1.261	18800					
BSH-118	.057	.068	50	.064	.0385	1950	.105	.182	.132	.072	.078	1.325	18000					
BSH-125	.057	.068	45	.068	.041	1950	.111	.183	.140	.076	.078	1.396	17000					
BSH-131	.057	.068	40	.068	.041	1950	.120	.183	.146	.0765	.078	1.458	16500					
BSH-137	.057	.068	35	.072	.043	1950	.126	.184	.152	.082	.078	1.529	16000					
BSH-143	.057	.068	30	.076	.045	1950	.132	.184	.160	.086	.078	1.600	15000					
BSH-150	.057	.068	30	.079	.047	1950	.141	.214	.168	.091	.120	1.668	14800					
BSH-162	.069	.094	.025	55	.087	.052	3000	.144	.235	.180	.097	.125	1.812	13200				
BSH-175	.069	.094		50	.091	.054	3000	.150	.237	.188	.101	.125	1.945	12200				

LARGER SIZES MAY BE AVAILABLE UPON REQUEST.

HARDNESS RANGES: CARBON STEEL RINGS (SAE 1060-1090)

RING TYPE	SIZE RANGE	SCALE	ROCKWELL HARDNESS
BSH	25-46	30N	69.5-73
	50-81	30N	66-71
	87-102	C	47-53
	106+	C	47-52

HARDNESS RANGES: BERYLLIUM COPPER RINGS

RING TYPE	SIZE RANGE	SCALE	ROCKWELL HARDNESS
BSH	18-23	15N	77-82*
	25-102	30N	54-62
	106+	C	34-43

*HARDNESS CAN NOT BE CHECKED WITH ANY DEGREE OF ACCURACY DIRECTLY ON THESE RINGS.



VHO Housing Rings

Axially Assembled, Internal Beveled

These rings look exactly like their HO counterpart, only they have a 15° angle on the outer edge. This combines with a complementary groove angle to eliminate endplay by wedging itself between the groove and the retained part.

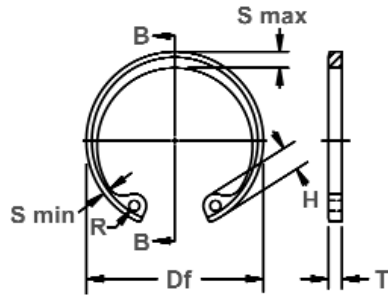

Free Diameter & Ring Measurements with Section B-B

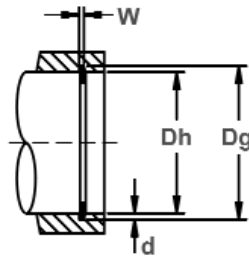

Housing Diameter & Groove Dimensions

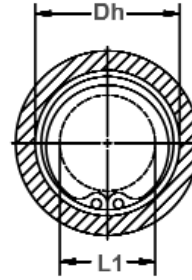

Clearance Diameter Compressed in Housing

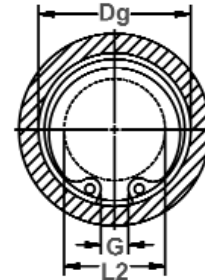

Clearance Diameter & Gap Width Released in Groove

RING NO.	HOUSING DIAMETER			GROOVE SIZE					RING SIZE & WEIGHT						CLEARANCE DIA.		
				DIAMETER		WIDTH		DEPTH	FREE DIAMETER			THICKNESS***		THICKNESS BEVELED END		Weight Per 1000 Pcs.	Compressed in housing
	Dh DEC	Dh FRACT	Dh mm	Dg	Tol.	W	Tol.	d	Df	Tol.	T	Tol.	U	Tol.	lbs.		
VHO-100	1.000	1	25.4	1.076	+.003	.036		.038	1.111	+.015	.042		.033		2.7	.665	.70
VHO-102	1.023	-	26.0	1.101	-.000	.036		.039	1.136	-.010	.042		.033		2.8	.69	.725
VHO-106	1.062	1-1/16	27.0	1.138	.004*	.044		.038	1.180		.050		.041		3.7	.685	.72
VHO-112	1.125	1-1/8	28.6	1.205		.043		.040	1.249		.050		.040		4.0	.745	.78
VHO-118	1.181	-	30.0	1.265		.043		.042	1.319		.050		.040		4.3	.66	.69
VHO-118	1.188	1-3/16	30.2	1.272		.043		.042	1.319		.050		.040		4.3	.67	.70
VHO-125	1.250	1-1/4	31.7	1.342		.042		.046	1.388	+.025	.050	±.002	.039		4.8	.875	.92
VHO-125	1.259	-	32.0	1.351	+.004	.042		.046	1.388	-.020	.050		.039		4.8	.885	.93
VHO-131	1.312	1-5/16	33.3	1.408	-.000	.042		.048	1.456		.050		.039		5.0	.93	.97
VHO-137	1.375	1-3/8	34.9	1.475	.005*	.041		.050	1.526		.050		.038		5.1	.99	1.03
VHO-137	1.378	-	35.0	1.478		.041	+.005	.050	1.526		.050		.038	±.001	5.1	.99	1.03
VHO-143	1.438	1-7/16	36.5	1.542		.040	-.000	.052	1.596		.050		.037		5.8	1.06	1.11
VHO-145	1.456	-	37.0	1.562		.040		.053	1.616		.050		.037		6.4	1.08	1.13
VHO-150	1.500	1-1/2	38.1	1.604		.040		.052	1.660		.050		.037		6.5	1.12	1.17
VHO-156	1.562	1-9/16	39.7	1.674		.052		.056	1.734		.062		.048		8.9	1.10	1.15
VHO-156	1.575	-	40.0	1.687		.052		.056	1.734		.062		.048		8.9	1.11	1.16
VHO-162	1.625	1-5/8	41.3	1.743		.051		.059	1.804		.062		.047		10.0	1.16	1.22
VHO-165	1.653	-	42.0	1.773		.051		.060	1.835		.062		.047		10.4	1.17	1.22
VHO-168	1.688	1-11/16	42.9	1.810	+.005	.050		.061	1.874	+.035	.062		.046		10.8	1.21	1.27
VHO-175	1.750	1-3/4	44.4	1.878	-.000	.050		.064	1.942	-.025	.062		.046		10.3	1.27	1.32
VHO-181	1.812	1-13/16	46.0	1.944	.005*	.050		.066	2.012		.062	±.003	.046		11.5	1.34	1.40
VHO-185	1.850	-	47.0	1.984		.050		.067	2.054		.062		.046		12.8	1.36	1.43
VHO-187	1.875	1-7/8	47.6	2.011		.050		.068	2.054		.062		.046		12.8	1.38	1.45
VHO-193	1.938	1-15/16	49.2	2.082		.049		.072	2.141		.062		.045		13.3	1.46	1.53
VHO-200	2.000	2	50.8	2.144		.048		.072	2.210		.062		.044		14.0	1.52	1.59
VHO-206	2.047	-	52.0	2.195		.065		.074	2.280		.078		.060		18.0	1.52	1.59
VHO-206	2.062	2-1/16	52.4	2.210	+.006	.065	+.007	.074	2.280	+.040	.078		.060		18.0	1.54	1.61
VHO-212	2.125	2-1/8	54.0	2.279	-.000	.065	-.000	.077	2.350	-.030	.078		.060	±.0015	19.4	1.60	1.67
VHO-218	2.165	-	55.0	2.327	.006*	.064		.081	2.415		.078		.059		19.6	1.63	1.71
VHO-218	2.188	2-3/16	55.6	2.350		.064		.081	2.415		.078		.059		19.6	1.66	1.74

† BASED ON HOUSINGS/SHAFTS MADE OF COLD ROLLED STEEL.

NOTE: CONTACT ROTOR CLIP FOR AVAILABILITY OF SIZES LISTED.

* F.I.M. (FULL INDICATOR MOVEMENT)- MAXIMUM ALLOWABLE DEVIATION OF CONCENTRICITY BETWEEN GROOVE AND HOUSING.

***FOR PLATED RINGS ADD .002" TO THE LISTED MAXIMUM THICKNESS (T) AND BEVELED END THICKNESS (U) VALUES.

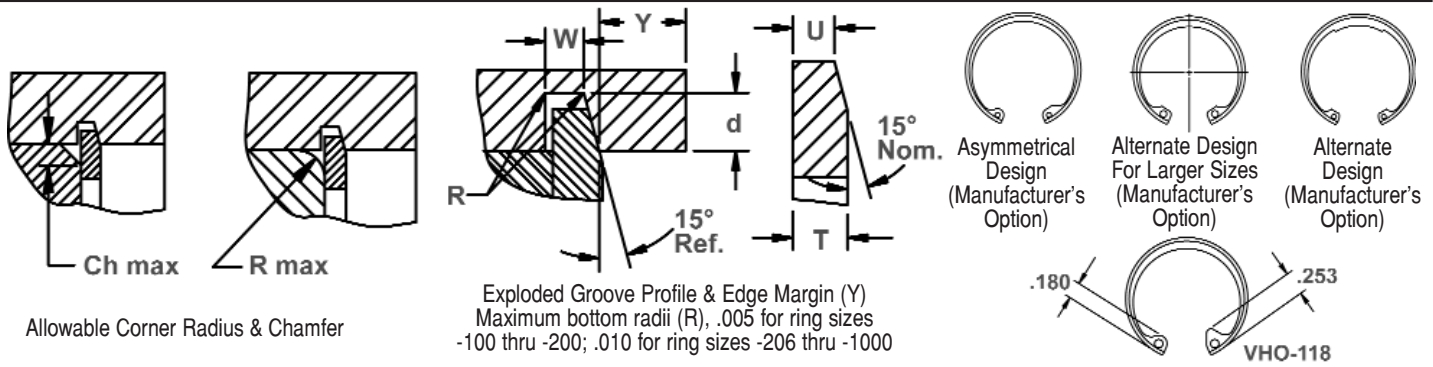

RING NO.	ALLOWABLE CORNER RADII & CHAMFERS		MAX. LOAD w/ R max or Ch max (in lbs.)	EDGE MARGIN	END-PLAY TAKE-UP	LUG HEIGHT		MAXIMUM SECTION		MINIMUM SECTION		HOLE DIAMETER		GAP WIDTH Ring in groove	THRUST LD. (lbs.) Sqr. corner abutment					
	R max	Ch max				Pr	Y	In.	H	Tol.	S max	Tol.	S min		Tol.	R	Tol.	G min	Pr	Pg
VHO-100	.042	.034	1650	.057	.005	.155		.104	±.005	.052	±.005	.062	+.010	.145	6039	1600				
VHO-102	.042	.034	1650	.058	.005	.155		.106		.054		.062	-.002	.150	6141	1700				
VHO-106	.044	.035	2400	.057	.005	.180		.110		.055		.078		.143	7562	1700				
VHO-112	.047	.036	2400	.060	.005	.180		.116		.057		.078		.157	8019	1900				
VHO-118	.047	.036	2400	.063	.0055	.180		.120		.058		.078		.150	8526	2100				
VHO-118	.047	.036	2400	.063	.0055	.180		.120		.058		.078		.169	8526	2100				
VHO-125	.048	.038	2400	.069	.006	.180		.124	±.006	.062	±.006	.078		.184	8932	2400				
VHO-125	.048	.038	2400	.069	.006	.180		.124		.062		.078		.209	8932	2400				
VHO-131	.048	.038	2400	.072	.006	.180		.130		.062		.078		.198	9440	2650				
VHO-137	.048	.038	2400	.075	.0065	.180		.130		.063		.078		.211	9846	2900				
VHO-137	.048	.038	2400	.075	.0065	.180		.130		.063		.078		.219	9846	2900				
VHO-143	.048	.038	2400	.078	.007	.180		.133		.065		.078		.221	10353	3100				
VHO-145	.048	.038	2400	.078	.007	.180		.133		.065		.078		.226	10455	3250				
VHO-150	.048	.038	2400	.078	.007	.180	±.005	.133		.066		.078	+.015	.238	10708	3300				
VHO-156	.064	.050	3900	.084	.0075	.202		.157		.078		.078	-.002	.238	13906	3600				
VHO-156	.064	.050	3900	.084	.0075	.202		.157		.078		.078		.275	13906	3600				
VHO-162	.064	.050	3900	.088	.008	.230		.164		.082		.078		.242	14413	4000				
VHO-165	.064	.050	3900	.090	.008	.230		.167		.083		.078		.245	14718	4200				
VHO-168	.064	.050	3900	.091	.008	.230		.170		.085		.078		.255	15022	4300				
VHO-175	.064	.050	3900	.096	.0085	.230		.171		.083		.078		.267	15580	4700				
VHO-181	.064	.050	3900	.099	.009	.230		.170	±.007	.084	±.007	.093		.277	16139	5050				
VHO-185	.064	.050	3900	.100	.009	.234		.170		.085		.093		.245	16443	5200				
VHO-187	.064	.050	3900	.102	.009	.234		.170		.085		.093		.310	16697	5400				
VHO-193	.064	.050	3900	.108	.0095	.230		.170		.085		.093		.328	17255	5900				
VHO-200	.064	.050	3900	.108	.0095	.230		.170		.085		.093		.332	17763	6100				
VHO-206	.076	.061	6200	.111	.0095	.250		.186		.091		.093		.311	23091	6500				
VHO-206	.078	.062	6200	.111	.0095	.250		.186		.091		.093		.349	23091	6500				
VHO-212	.078	.062	6200	.115	.010	.250		.195		.096		.093		.345	23751	7000				
VHO-218	.078	.062	6200	.121	.010	.250		.199		.098		.093		.323	24462	7450				
VHO-218	.078	.062	6200	.121	.010	.250		.199		.098		.093		.373	24462	7450				

FOR HARDNESS SPECIFICATIONS, SEE END OF THIS SECTION.



VHO Housing Rings

Axially Assembled, Internal Beveled

These rings look exactly like their HO counterpart, only they have a 15° angle on the outer edge. This combines with a complementary groove angle to eliminate endplay by wedging itself between the groove and the retained part.

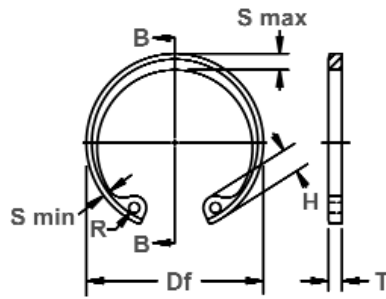

Free Diameter & Ring Measurements with Section B-B

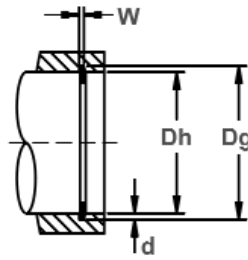

Housing Diameter & Groove Dimensions

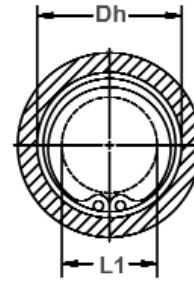

Clearance Diameter Compressed in Housing

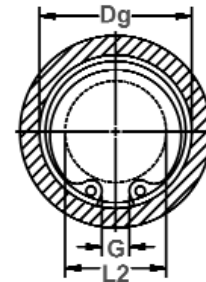

Clearance Diameter & Gap Width Released in Groove

RING NO.	HOUSING DIAMETER			GROOVE SIZE					RING SIZE & WEIGHT					CLEARANCE DIA.			
				DIAMETER		WIDTH		DEPTH	FREE DIAMETER	THICKNESS***		THICKNESS BEVELED END	Weight. Per 1000 Pcs.	Compressed in housing	Released in groove		
	Dh DEC	Dh FRACT	Dh mm	Dg	Tol.	W	Tol.	d		Df	Tol.					T	Tol.
VHO-225	2.250	2-1/4	57.1	2.420		.064		.085	2.490		.078		.059		21.8	1.67	1.75
VHO-231	2.312	2-5/16	58.7	2.484		.063		.086	2.560		.078		.058		22.6	1.73	1.80
VHO-237	2.375	2-3/8	60.3	2.552		.063		.089	2.630		.078		.058	±.0015	23.2	1.79	1.87
VHO-244	2.440	2-7/16	62.0	2.618		.062		.089	2.702		.078		.057		25.4	1.86	1.94
VHO-250	2.500	2-1/2	63.5	2.684		.062		.092	2.775		.078		.057		25.5	1.91	2.00
VHO-250	2.531	2-17/32	64.3	2.717		.062		.093	2.775		.078		.057		25.5	1.94	2.03
VHO-256	2.562	2-9/16	65.1	2.750		.078	+ .007	.094	2.844	+ .040	.093		.072		34.0	1.93	2.02
VHO-262	2.625	2-5/8	66.7	2.820		.077	- .000	.097	2.910	- .030	.093		.071		34.5	2.02	2.11
VHO-268	2.677	-	68.0	2.876		.077		.099	2.980		.093		.071		35.0	2.05	2.15
VHO-268	2.688	2-11/16	68.3	2.887		.077		.099	2.980		.093		.071		35.0	2.06	2.16
VHO-275	2.750	2-3/4	69.8	2.955		.076		.102	3.050		.093		.070	±.002	35.5	2.12	2.21
VHO-281	2.812	2-13/16	71.4	3.020		.076		.104	3.121		.093		.070		36.0	2.18	2.27
VHO-281	2.835	-	72.0	3.043	+ .006	.076		.104	3.121		.093		.070		36.0	2.21	2.31
VHO-287	2.875	2-7/8	73.0	3.085	- .000	.076		.105	3.191		.093	±.003	.070		41.0	2.24	2.34
VHO-300	2.953	-	75.0	3.178	.006*	.074		.112	3.325		.093		.068		42.5	2.32	2.43
VHO-300	3.000	3	76.2	3.225		.074		.112	3.325		.093		.068		42.5	2.37	2.48
VHO-306	3.062	3-1/16	77.8	3.290		.089		.114	3.418		.109		.082		53.0	2.41	2.51
VHO-312	3.125	3-1/8	79.4	3.355		.089		.115	3.488		.109		.082		56.0	2.47	2.58
VHO-315	3.149	-	80.0	3.381		.089		.116	3.523		.109		.082		57.0	2.49	2.60
VHO-315	3.156	3-5/32	80.2	3.388		.089		.116	3.523		.109		.082		57.0	2.50	2.61
VHO-325	3.250	3-1/4	82.5	3.489		.089		.119	3.623	±.055	.109		.082		60.0	2.54	2.65
VHO-334SP1	3.346	3-11/32	85.0	3.591		.089	+ .008	.122	3.734		.109		.082		65.0	2.63	2.74
VHO-347	3.469	3-15/32	88.1	3.726		.089	- .000	.128	3.857		.109		.082	±.0025	69.0	2.76	2.88
VHO-350	3.500	3-1/2	88.9	3.760		.089		.130	3.890		.109		.082		71.0	2.79	2.91
VHO-354SP1	3.543	-	90.0	3.806		.089		.132	3.936		.109		.082		72.0	2.83	2.95
VHO-354SP1	3.562	3-9/16	90.5	3.830		.089		.134	3.936		.109		.082		72.0	2.85	2.97
VHO-362	3.625	3-5/8	92.1	3.900		.089		.137	4.024		.109		.082		73.0	2.91	3.03
VHO-375	3.740	-	95.0	4.030		.089		.145	4.157		.109		.082		78.0	3.02	3.15
VHO-375	3.750	3-3/4	95.2	4.040		.089		.145	4.157		.109		.082		78.0	3.03	3.17
VHO-387	3.875	3-7/8	98.4	4.171		.089		.148	4.291	±.065	.109		.082		87.0	3.11	3.25
VHO-393	3.938	3-15/16	100.0	4.236		.089		.149	4.358		.109		.082		88.0	3.17	3.31
VHO-400	4.000	4	101.6	4.302		.089		.151	4.424		.109		.082		93.0	3.23	3.37

† BASED ON HOUSINGS/SHAFTS MADE OF COLD ROLLED STEEL.

NOTE: CONTACT ROTOR CLIP FOR AVAILABILITY OF SIZES LISTED.

* F.I.M. (FULL INDICATOR MOVEMENT)- MAXIMUM ALLOWABLE DEVIATION OF CONCENTRICITY BETWEEN GROOVE AND HOUSING.

***FOR PLATED RINGS ADD .002" TO THE LISTED MAXIMUM THICKNESS (T) AND BEVELED END THICKNESS (U) VALUES.

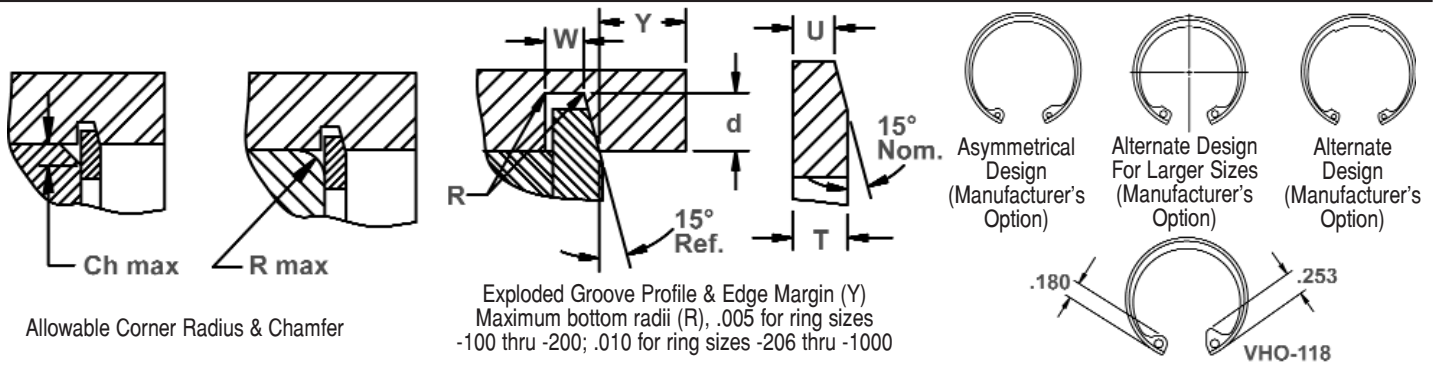

RING NO.	ALLOWABLE CORNER RADII & CHAMFERS		MAX. LOAD w/ R max or Ch max (in lbs.)	EDGE MARGIN	END-PLAY TAKE-UP	LUG HEIGHT		MAXIMUM SECTION		MINIMUM SECTION		HOLE DIAMETER		GAP WIDTH Ring in groove	THRUST LD. (lbs.) Sqr. corner abutment	
	R max	Ch max				P'r	Y	In.	H	Tol.	S max	Tol.	S min		Tol.	R
VHO-225	.078	.062	6200	.127	.0105	.280		.203		.099		.093		.368	25223	8050
VHO-231	.078	.062	6200	.129	.011	.280		.206		.100		.093		.362	25832	8400
VHO-237	.078	.062	6200	.133	.0115	.280		.207		.102		.093		.374	26542	8900
VHO-244	.078	.062	6200	.133	.012	.280		.209		.103		.110		.386	27304	9100
VHO-250	.078	.062	6200	.138	.012	.280		.210		.103		.110		.398	28014	9600
VHO-250	.078	.062	6200	.139	.0125	.280		.210		.103		.110		.460	28014	9600
VHO-256	.088	.070	9000	.141	.0125	.300	±.005	.222	±.007	.109	±.007	.110		.400	34206	10200
VHO-262	.088	.070	9000	.145	.013	.290		.226		.111		.110		.418	35068	10800
VHO-268	.090	.072	9000	.148	.013	.300		.230		.113		.110		.393	35931	11300
VHO-268	.090	.072	9000	.148	.013	.300		.230		.113		.110		.423	35931	11300
VHO-275	.092	.074	9000	.153	.014	.300		.234		.115		.110		.442	36642	11800
VHO-281	.088	.070	9000	.156	.014	.300		.230		.115		.110		.459	37504	12200
VHO-281	.088	.070	9000	.156	.014	.300		.230		.115		.110		.512	37504	12200
VHO-287	.092	.074	9000	.157	.014	.300		.240		.120		.110		.451	38367	12600
VHO-300	.092	.074	9000	.168	.015	.300		.250		.122		.110	±.015	.449	40093	14200
VHO-300	.092	.074	9000	.168	.015	.300		.250		.122		.110	-.002	.568	40093	14200
VHO-306	.097	.078	12000	.171	.015	.310		.254		.126		.125		.473	47807	14800
VHO-312	.099	.079	12000	.172	.0155	.310		.259		.129		.125		.469	48822	15200
VHO-315	.100	.080	12000	.174	.0155	.310		.262		.129		.125		.462	49329	15500
VHO-315	.100	.080	12000	.174	.0155	.310		.262		.129		.125		.481	49329	15500
VHO-325	.104	.083	12000	.178	.016	.342		.269		.135		.125		.509	50750	16400
VHO-334SP1	.108	.086	12000	.183	.0165	.342		.276		.140		.125		.514	52374	17300
VHO-347	.108	.086	12000	.192	.017	.342	±.008	.286	±.008	.144	±.008	.125		.571	54201	18800
VHO-350	.110	.088	12000	.195	.017	.342		.289		.142		.125		.574	54709	19300
VHO-354SP1	.110	.088	12000	.198	.0175	.342		.292		.142		.125		.586	55419	19800
VHO-354SP1	.110	.088	12000	.201	.018	.342		.292		.142		.125		.643	55419	19800
VHO-362	.116	.093	12000	.205	.018	.342		.299		.150		.125		.639	56739	21100
VHO-375	.120	.096	12000	.217	.0195	.342		.309		.155		.125		.647	58566	23100
VHO-375	.120	.096	12000	.217	.0195	.342		.309		.155		.125		.674	58566	23100
VHO-387	.123	.098	12000	.222	.020	.370		.319		.160		.125		.680	60494	24300
VHO-393	.124	.099	12000	.223	.020	.370		.324		.161		.125		.687	61611	24900
VHO-400	.128	.102	12000	.226	.020	.370		.330		.166		.125		.694	62626	25600

FOR HARDNESS SPECIFICATIONS, SEE END OF THIS SECTION.



VHO Housing Rings

Axially Assembled, Internal Beveled

These rings look exactly like their HO counterpart, only they have a 15° angle on the outer edge. This combines with a complementary groove angle to eliminate endplay by wedging itself between the groove and the retained part.

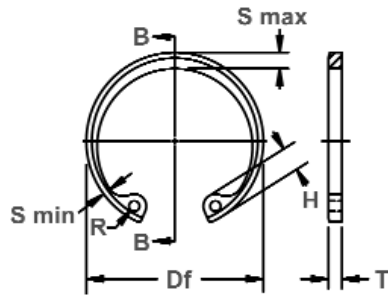

Free Diameter & Ring Measurements with Section B-B

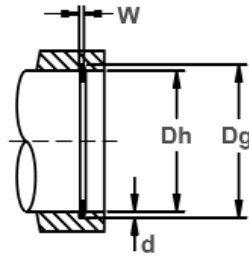

Housing Diameter & Groove Dimensions

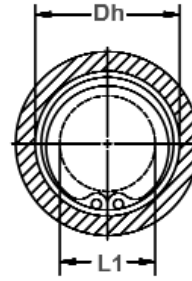

Clearance Diameter Compressed in Housing

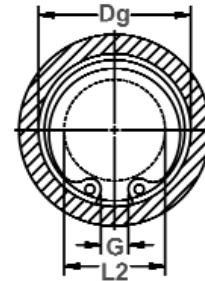

Clearance Diameter & Gap Width Released in Groove

RING NO.	HOUSING DIAMETER			GROOVE SIZE					RING SIZE & WEIGHT					CLEARANCE			
				DIAMETER		WIDTH		DEPTH	FREE DIAMETER			THICKNESS***		THICKNESS BEVELED END	Weight. Per 1000 Pcs.	Compressed in housing	Re-released in groove
	Dh DEC	Dh FRACT	Dh mm	Dg	Tol.	W	Tol.	d	Df	Tol.	T	Tol.	U	Tol.			
VHO-412	4.125	4-1/8	104.8	4.433		.089		.154	4.558		.109		.082		97.0	3.36	3.51
VHO-425	4.250	4-1/4	108.0	4.562		.089		.156	4.691		.109		.082		101.0	3.48	3.63
VHO-433	4.331	-	110.0	4.647	+.006	.089	+.008	.158	4.756		.109		.082		105.0	3.50	3.65
VHO-450	4.500	4-1/2	114.3	4.824	-.000	.089	-.000	.162	4.940		.109	±.003	.082	±.0025	111.00	3.66	3.81
VHO-462	4.625	4-5/8	117.5	4.955	.006*	.089		.165	5.076		.109		.082		117.00	3.79	3.95
VHO-475	4.724	-	120.0	5.060		.089		.168	5.213		.109		.082		124.0	3.88	4.04
VHO-475	4.750	4-3/4	120.6	5.086		.089		.168	5.213	±.065	.109		.082		124.0	3.90	4.06
VHO-500	5.000	5	127.0	5.346		.089		.173	5.485		.109		.082		136.0	4.08	4.25
VHO-525	5.250	5-1/4	133.3	5.612		.102		.181	5.770		.125		.095		174.0	4.35	4.52
VHO-537	5.375	5-3/8	136.5	5.739	+.007	.102		.182	5.910		.125		.095		179.0	4.45	4.62
VHO-550	5.500	5-1/2	139.7	5.864	-.000	.102		.182	6.066		.125	±.004	.095		183.0	4.57	4.74
VHO-575	5.750	5-3/4	146.0	6.120	.006*	.102		.185	6.336		.125		.095		192.0	4.82	5.00
VHO-600	6.000	6	152.4	6.374		.102		.187	6.620		.125		.095		201.0	5.07	5.25
VHO-625	6.250	6-1/4	158.7	6.642		.129		.196	6.895		.156		.121		266.0	5.24	5.43
VHO-650	6.500	6-1/2	165.1	6.908		.129		.204	7.170		.156		.121		281.0	5.49	5.68
VHO-662	6.625	6-5/8	168.3	7.042		.129		.208	7.308	±.080	.156		.121		305.0	5.60	5.80
VHO-675	6.750	6-3/4	171.4	7.174		.128	+.010	.212	7.445		.156		.120		325.0	5.68	5.88
VHO-700	7.000	7	177.8	7.441		.128	-.000	.220	7.720		.156		.120		344.0	5.91	6.12
VHO-725	7.250	7-1/4	184.1	7.708	+.008	.159		.229	7.995		.187		.150	±.003	428.0	6.11	6.33
VHO-750	7.500	7-1/2	190.5	7.974	-.000	.159		.237	8.270		.187		.150		485.0	6.36	6.59
VHO-775	7.750	7-3/4	196.8	8.240	.006	.159		.245	8.545		.187	±.005	.150		520.0	6.58	6.82
VHO-800	8.000	8	203.2	8.507		.155		.253	8.820		.187		.146		555.0	6.83	7.07
VHO-825	8.250	8-1/4	209.5	8.773		.155		.261	9.095		.187		.146		603.0	7.04	7.29
VHO-850	8.500	8-1/2	215.9	9.040		.151		.270	9.285	±.090	.187		.142		634.0	7.29	7.55
VHO-875	8.750	8-3/4	222.2	9.307		.151		.278	9.558		.187		.142		653.0	7.38	7.65
VHO-900	9.000	9	228.6	9.573		.151		.286	9.830		.187		.142		732.0	7.63	7.91
VHO-925	9.250	9-1/4	235.0	9.838		.151		.294	10.102		.187		.142		767.0	7.88	8.16
VHO-950	9.500	9-1/2	241.3	10.106		.147		.303	10.375		.187		.138		803.0	7.98	8.27
VHO-975	9.750	9-3/4	247.7	10.372		.147		.311	10.648		.187		.138		833.0	8.23	8.52
VHO-1000	10.000	10	254.0	10.639		.147		.319	10.920		.187		.138		863.0	8.48	8.78

† BASED ON HOUSINGS/SHAFTS MADE OF COLD ROLLED STEEL.

NOTE: CONTACT ROTOR CLIP FOR AVAILABILITY OF SIZES LISTED.

* F.I.M. (FULL INDICATOR MOVEMENT)- MAXIMUM ALLOWABLE DEVIATION OF CONCENTRICITY BETWEEN GROOVE AND HOUSING.

***FOR PLATED RINGS ADD .002" TO THE LISTED MAXIMUM THICKNESS (T) AND BEVELED END THICKNESS (U) VALUES.

HARDNESS RANGES: STAINLESS STEEL RINGS (PH 15-7MO)

RING TYPE	SIZE RANGE	SCALE	ROCKWELL HARDNESS
VHO	100&102	30N	63-69.5
	106+	C	44-51



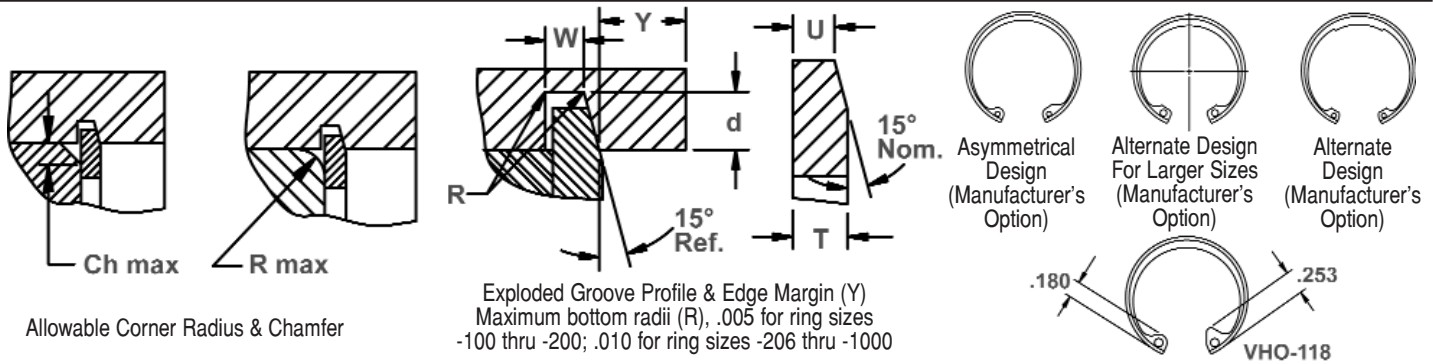

RING NO.	ALLOWABLE CORNER RADII & CHAMFERS		MAX. LOAD w/ R max or Ch max (in lbs.)	EDGE MARGIN	END-PLAY TAKE-UP	LUG HEIGHT		MAXIMUM SECTION		MINIMUM SECTION		HOLE DIAMETER		GAP WIDTH Ring in groove	THRUST LD. (lbs.)					
	R max	Ch max				Pr	Y	In.	H	Tol.	S max	Tol.	S min		Tol.	R	Tol.	G min	Pr	Pg
VHO-412	.130	.104	12000	.231	.021	.370		.330		.171		.125	+.015	.718	64554	26900				
VHO-425	.138	.110	12000	.234	.021	.370		.335		.180		.125	-.002	.743	66483	28100				
VHO-433	.142	.114	12000	.237	.021	.405		.343		.180		.156		.803	67599	29000				
VHO-450	.146	.117	12000	.243	.022	.405	±.008	.351		.181		.156		.787	70340	30900				
VHO-462	.151	.121	12000	.247	.022	.405		.405		.183		.156		.822	72370	32400				
VHO-475	.154	.123	12000	.252	.023	.405		.370		.183		.156		.773	74298	33800				
VHO-475	.154	.123	12000	.252	.023	.405		.370		.183		.156		.843	74298	33800				
VHO-500	.158	.126	12000	.259	.023	.435		.435		.186		.156		.753	78155	38700				
VHO-525	.168	.134	15000	.271	.024	.435		.435		.198		.156		.886	94091	40300				
VHO-537	.168	.134	15000	.273	.024	.435		.435	±.009	.198	±.009	.156		.893	96324	41500				
VHO-550	.168	.134	15000	.273	.024	.435		.435		.198		.156		.879	98658	42500				
VHO-575	.168	.134	15000	.277	.025	.435		.435		.198		.156		.905	103124	45100				
VHO-600	.168	.134	15000	.280	.025	.435		.435		.198		.156		.929	107489	47600				
VHO-625	.177	.142	23000	.294	.026	.485		.485		.211		.187	+.020	.956	139766	52000				
VHO-650	.181	.145	23000	.306	.027	.485		.485		.219		.187	-.005	1.040	145450	56200				
VHO-662	.183	.146	23000	.312	.028	.485		.485		.221		.187		1.063	148190	58400				
VHO-675	.188	.150	23000	.318	.028	.515		.515		.224		.187		.985	151032	60700				
VHO-700	.196	.157	23000	.330	.029	.515	±.010	.515		.232		.187		1.037	156615	65300				
VHO-725	.202	.162	34000	.343	.031	.545		.545		.238		.187		1.085	194373	70400				
VHO-750	.208	.166	34000	.355	.032	.545		.545		.247		.187		1.138	201173	75400				
VHO-775	.214	.171	34000	.367	.033	.560		.560		.255		.187		1.178	207872	80500				
VHO-800	.220	.176	34000	.379	.034	.560		.560		.262		.187		1.238	214571	85800				
VHO-825	.229	.183	34000	.391	.035	.580		.580	±.010	.270	±.010	.187		1.269	221270	91300				
VHO-850	.235	.188	34000	.405	.036	.580		.580		.277		.187		1.444	227969	97300				
VHO-875	.241	.193	34000	.417	.037	.660		.591		.286		.187		1.481	233856	103200				
VHO-900	.249	.199	34000	.429	.038	.660		.609		.294		.187		1.539	241367	109200				
VHO-925	.253	.202	34000	.441	.039	.660		.625		.299		.187		1.559	248066	115300				
VHO-950	.258	.206	34000	.454	.041	.735		.642		.304		.187		1.596	254765	122100				
VHO-975	.263	.210	34000	.466	.042	.735		.658		.309		.187		1.680	261464	128600				
VHO-1000	.270	.216	34000	.478	.043	.735		.675		.315		.187		1.687	268163	135300				

HARDNESS RANGES: CARBON STEEL RINGS (SAE 1060-1090)

RING TYPE	SIZE RANGE	SCALE	ROCKWELL HARDNESS
VHO	100&102	30N	66-71
	106-347	C	47-52
	350-700	C	44-51
	725-1000	C	40-47

HARDNESS RANGES: BERYLLIUM COPPER RINGS

RING TYPE	SIZE RANGE	SCALE	ROCKWELL HARDNESS
VHO	100&102	30N	54-62
	106+	C	34-43





VSH Shaft Rings

Axially Assembled, External Beveled

These rings look exactly like their SH counterpart, only they have a 15° angle on the inner edge. This combines with a complimentary groove angle to eliminate endplay by wedging itself between the groove and the retained part.

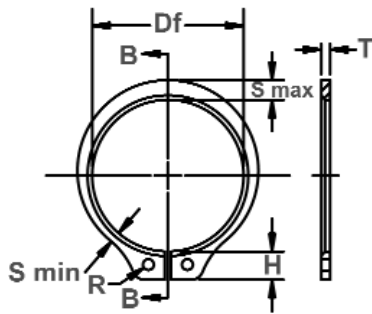

Free Diameter & Ring Measurements with Section B-B

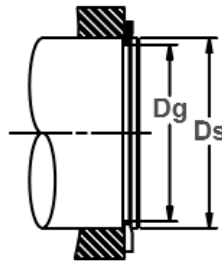

Shaft Diameter & Groove Dimensions

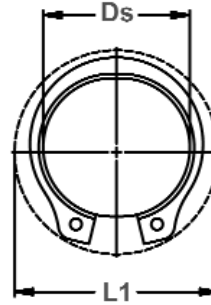

Clearance Diameter Expanded Over Shaft

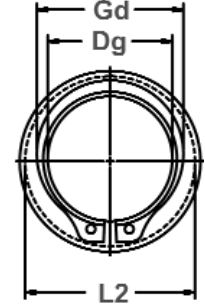

Clearance Diameter & Gaging Diameter Released in Groove

RING NO.	SHAFT DIAMETER			GROOVE SIZE			RING SIZE & WEIGHT						CLEARANCE DIA.			
				DIAMETER		WIDTH	DEPTH	FREE DIAMETER	THICKNESS***		THICKNESS BEVELED END	WEIGHT PER 1000 PCS.	EX-PANDED OVER SHAFT	RE-LEASED IN GROOVE		
	Ds DEC	Ds FRACT	Ds mm	Dg	Tol.	W Tol.	d	Df	Tol.	T	Tol.	U	Tol.	lbs.	L1	L2
VSH-100	1.000	1	25.4	.930	+.000	.037	.035	.925	+.005	.042		.034		3.6	1.41	1.38
VSH-102	1.023	-	26.0	.951	-.003 .004*	.036	.036	.946	-.010	.042		.033		3.9	1.43	1.40
VSH-106	1.062	1-1/16	27.0	.992		.044	.035	.982		.050		.041		4.8	1.50	1.47
VSH-112	1.125	1-1/8	28.6	1.051		.044	.037	1.041		.050		.041		5.1	1.55	1.52
VSH-119	1.188	1-3/16	30.2	1.108	+.000	.044	.040	1.098	+.010	.050	±.002	.041		5.6	1.61	1.57
VSH-125	1.250	1-1/4	31.7	1.166	-.004	.043	.042	1.156	-.015	.050		.040		5.9	1.69	1.65
VSH-131	1.312	1-5/16	33.3	1.224	.005*	.042	.044	1.214		.050		.039		6.8	1.75	1.71
VSH-137	1.375	1-3/8	34.9	1.282		.042	.046	1.272		.050		.039		7.2	1.80	1.76
VSH-143	1.438	1-7/16	36.5	1.343		.042	.047	1.333		.050		.039	±.001	8.1	1.87	1.83
VSH-150	1.500	1-1/2	38.1	1.397		.041	.051	1.387	-.005	.050		.038		9.0	1.99	1.95
VSH-157	1.562	1-9/16	39.7	1.459		.053	.051	1.446		.062		.049		12.4	2.10	2.05
VSH-162	1.625	1-5/8	41.3	1.516		.053	.054	1.503		.062		.049		13.2	2.17	2.13
VSH-168	1.688	1-11/16	42.9	1.573		.052	.057	1.560		.062		.048		14.8	2.24	2.20
VSH-175	1.750	1-3/4	44.4	1.631	+.000	.052	.059	1.618	+.013	.062		.048		15.3	2.31	2.26
VSH-177	1.772	-	45.0	1.650	-.005	.052	.061	1.637	-.020	.062		.048		15.4	2.33	2.28
VSH-181	1.812	1-13/16	46.0	1.688	.005*	.052	.062	1.675		.062		.048		16.2	2.38	2.33
VSH-187	1.875	1-7/8	47.6	1.748		.052	.063	1.735		.062		.048		17.3	2.44	2.39
VSH-196	1.969	1-31/32	50.0	1.832		.051	.068	1.819		.062		.047		18.0	3.09	2.54
VSH-200	2.000	2	50.8	1.863		.051	.068	1.850		.062		.047		19.0	3.10	2.57
VSH-206	2.062	2-1/16	52.4	1.921		.067	.070	1.906		.078		.062		25.0	3.22	2.68
VSH-212	2.125	2-1/8	54.0	1.979		.067	.073	1.964		.078		.062		26.1	3.29	2.78
VSH-215	2.156	2-5/32	54.8	2.008		.067	.074	1.993		.078	±.003	.062		26.3	3.40	2.81
VSH-225	2.250	2-1/4	57.1	2.096		.066	.077	2.081	+.015	.078		.061		27.7	3.51	2.90
VSH-231	2.312	2-5/16	58.7	2.154		.065	.079	2.139	-.025	.078		.060	±.0015	28.0	3.58	2.97
VSH-237	2.375	2-3/8	60.3	2.212		.065	.081	2.197		.078		.060		29.2	3.50	3.06
VSH-243	2.438	2-7/16	61.9	2.270	+.000	.065	.084	2.255		.078		.060		29.5	3.64	3.07
VSH-250	2.500	2-1/2	63.5	2.328	-.006	.064	.086	2.313	-.005	.078		.059		29.7	3.17	3.09
VSH-255	2.559	-	65.0	2.397	.006*	.064	.081	2.377		.078		.059		33.9	3.18	3.10
VSH-262	2.625	2-5/8	66.7	2.448		.064	.088	2.428		.078		.059		35.0	3.30	3.22
VSH-268	2.688	2-11/16	68.3	2.505		.064	.091	2.485		.078		.059		36.0	3.37	3.29
VSH-275	2.750	2-3/4	69.8	2.563		.079	.093	2.543	+.020	.093		.073		47.0	3.48	3.40
VSH-287	2.875	2-7/8	73.0	2.679		.078	.098	2.659	-.030	.093		.072	±.002	48.5	3.60	3.51
VSH-293	2.938	2-15/16	74.6	2.737		.078	.100	2.717		.093		.072		50.0	3.67	3.58
VSH-300	3.000	3	76.2	2.795		.077	.102	2.775		.093		.071		52.0	3.60	3.50
VSH-306	3.062	3-1/16	77.8	2.852		.077	.105	2.832		.093		.071		47.0	3.74	3.64

*** FOR PLATED RINGS, ADD .002" TO THE LISTED MAXIMUM THICKNESS (T) AND BEVELED END THICKNESS (U) VALUES.

* F.I.M. (FULL INDICATOR MOVEMENT)-MAXIMUM ALLOWABLE DEVIATION OF CONCENTRICITY BETWEEN GROOVE AND SHAFT. FOR HARDNESS SPECIFICATIONS, SEE END OF THIS SECTION.

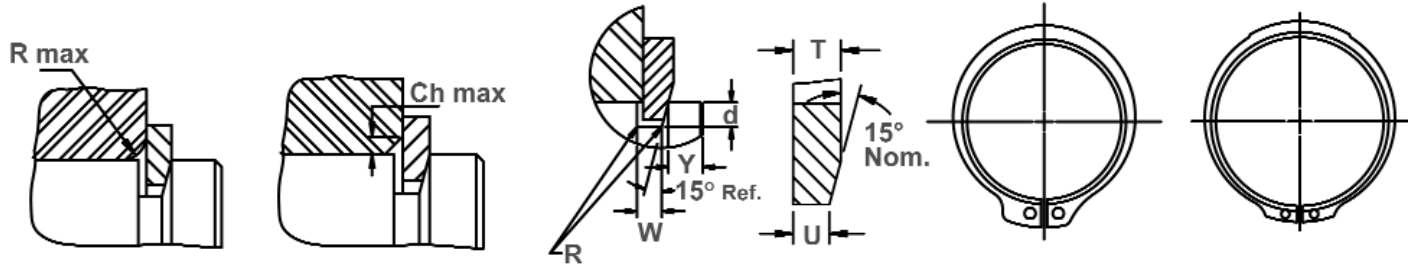

Maximum Corner Radius & Chamfer

Exploded Groove Profile & Edge Margin
Maximum bottom radii (R), .005 for ring sizes -100 thru -200; .010 for ring sizes -206 thru -1000

Asymmetrical Design
Manufacturer's Option

Alternate Lug Design
Manufacturer's Option
For Larger Sizes

RING NO.	ALLOWABLE CORNER RADII & CHAMFERS		MAX LOAD W/ R MAX OR CH MAX (IN LBS.)	EDGE MARGIN Y	END PLAY TAKE-UP In.	LUG HEIGHT H		MAXIMUM SECTION S max		MINIMUM SECTION S min		HOLE DIAMETER R		GAGING DIA. Gd Max	THRUST LOAD (lbs.) SQR. CORNER ABUTMENT	
	R max	Ch max				P'r	±	Tol.	±	Tol.	±	Tol.	±		Tol.	Pr
VSH-100	.057	.034	1340	.052	.005	.167	±.004	.116	±.005	.065	±.005	.078	±.015	1.144	5024	1200
VSH-102	.058	.035	1340	.054	.005	.168	±.004	.118	±.005	.066	±.005	.078	±.015	1.170	5126	1300
VSH-106	.060	.036	1950	.052	.005	.181	±.004	.122	±.006	.069	±.006	.078	±.015	1.217	6293	1300
VSH-112	.063	.038	1950	.055	.005	.182	±.004	.128	±.006	.071	±.006	.078	±.015	1.286	6699	1450
VSH-119	.064	.0385	1950	.060	.005	.198	±.004	.132	±.006	.072	±.006	.078	±.015	1.351	7105	1650
VSH-125	.068	.041	1950	.063	.0055	.183	±.004	.140	±.006	.076	±.006	.078	±.015	1.424	7460	1850
VSH-131	.068	.041	1950	.066	.006	.183	±.004	.146	±.006	.0765	±.006	.078	±.015	1.490	7866	2000
VSH-137	.072	.043	1950	.069	.006	.184	±.004	.152	±.006	.082	±.006	.078	±.015	1.562	8222	2250
VSH-143	.076	.045	1950	.070	.006	.184	±.004	.160	±.006	.086	±.006	.078	±.015	1.636	8628	2450
VSH-150	.079	.047	1950	.076	.007	.214	±.004	.168	±.006	.091	±.006	.120	±.015	1.706	8932	2700
VSH-157	.082	.049	3000	.076	.007	.255	±.005	.172	±.007	.093	±.007	.125	±.015	1.778	11571	2900
VSH-162	.087	.052	3000	.081	.0075	.235	±.005	.180	±.007	.097	±.007	.125	±.015	1.849	12028	3100
VSH-168	.090	.054	3000	.085	.0075	.235	±.005	.184	±.007	.099	±.007	.125	±.015	1.912	12535	3400
VSH-175	.091	.054	3000	.088	.008	.260	±.005	.188	±.007	.101	±.007	.125	±.015	1.981	12992	3650
VSH-177	.092	.055	3000	.090	.008	.237	±.005	.190	±.007	.102	±.007	.125	±.015	2.004	13144	3750
VSH-181	.092	.055	3000	.093	.008	.238	±.005	.192	±.007	.102	±.007	.125	±.015	2.047	13449	3950
VSH-187	.094	.056	3000	.094	.0085	.239	±.005	.196	±.007	.104	±.007	.125	±.015	2.114	13906	4200
VSH-196	.094	.056	3000	.102	.009	.245	±.005	.200	±.007	.106	±.007	.125	±.015	2.209	14565	4700
VSH-200	.096	.057	3000	.102	.009	.239	±.005	.204	±.007	.108	±.007	.125	±.015	2.246	14819	4800
VSH-206	.098	.059	5000	.105	.0095	.266	±.005	.208	±.007	.111	±.007	.125	±.015	2.315	19234	5100
VSH-212	.098	.059	5000	.109	.010	.280	±.005	.212	±.007	.113	±.007	.125	±.015	2.386	19793	5450
VSH-215	.097	.058	5000	.111	.010	.280	±.005	.212	±.007	.113	±.007	.125	±.015	2.410	20097	5600
VSH-225	.100	.060	5000	.115	.010	.280	±.005	.220	±.007	.116	±.007	.125	±.015	2.513	21011	6100
VSH-231	.100	.060	5000	.118	.0105	.280	±.005	.222	±.007	.118	±.007	.125	±.015	2.577	21518	6300
VSH-237	.100	.060	5000	.121	.011	.292	±.005	.224	±.007	.119	±.007	.125	±.015	2.640	22127	6800
VSH-243	.102	.061	5000	.126	.011	.268	±.005	.228	±.007	.120	±.007	.125	±.015	2.706	22736	7100
VSH-250	.104	.062	5000	.129	.0115	.292	±.005	.232	±.007	.122	±.007	.125	±.015	2.772	23345	7500
VSH-255	.108	.065	5000	.121	.011	.268	±.005	.238	±.007	.125	±.007	.125	±.015	2.845	23853	7300
VSH-262	.1095	.066	5000	.132	.0115	.292	±.005	.242	±.007	.127	±.007	.125	±.015	2.910	24462	8200
VSH-268	.1115	.067	5000	.136	.012	.292	±.005	.246	±.007	.129	±.007	.125	±.015	2.975	25071	8600
VSH-275	.112	.067	7350	.139	.012	.324	±.005	.248	±.007	.131	±.007	.125	±.015	3.041	30552	9000
VSH-287	.115	.069	7350	.147	.013	.324	±.005	.256	±.007	.133	±.007	.125	±.015	3.172	31973	9900
VSH-293	.116	.070	7350	.150	.0135	.324	±.005	.260	±.007	.136	±.007	.125	±.015	3.239	32683	10300
VSH-300	.117	.070	7350	.153	.0135	.264	±.005	.264	±.007	.138	±.007	.125	±.015	3.306	33394	10700
VSH-306	.107	.064	7350	.157	.014	.300	±.005	.300	±.007	.131	±.007	.125	±.015	3.347	34003	11200

† BASED ON HOUSINGS/SHAFTS MADE OF COLD ROLLED STEEL. FOR AN EXPLANATION OF FORMULAS USED TO DERIVE THRUST LOAD AND OTHER PERFORMANCE DATA, CONTACT THE ROTOR CLIP ENGINEERING DEPARTMENT. FOR HARDNESS SPECIFICATIONS, SEE END OF THIS SECTION.



VSH Shaft Rings

Axially Assembled, External Beveled

These rings look exactly like their SH counterpart, only they have a 15° angle on the inner edge. This combines with a complimentary groove angle to eliminate endplay by wedging itself between the groove and the retained part.

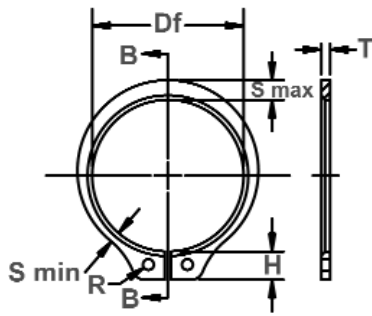

Free Diameter & Ring Measurements with Section B-B

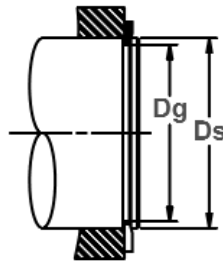

Shaft Diameter & Groove Dimensions

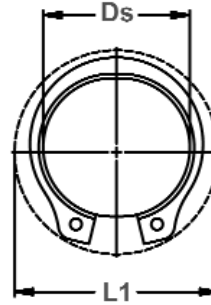

Clearance Diameter Expanded Over Shaft

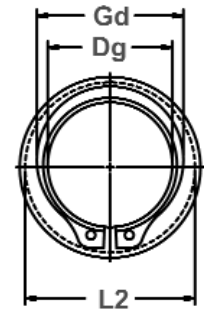

Clearance Diameter & Gaging Diameter Released in Groove

RING NO.	SHAFT DIAMETER			GROOVE SIZE					RING SIZE & WEIGHT					CLEARANCE DIA.			
				DIAMETER		WIDTH		DEPTH	FREE DIAMETER		THICKNESS***		THICKNESS BEVELED END		WEIGHT PER 1000 PCS.	EX-PANDED OVER SHAFT	RE-LEASED IN GROOVE
	Ds DEC	Ds FRACT	Ds mm	Dg	Tol.	W	Tol.	d	Df	Tol.	T	Tol.	U	Tol.	lbs.	L1	L2
VSH-312	3.125	3-1/8	79.4	2.912		.076		.106	2.892		.093		.070		58.0	3.85	3.76
VSH-315	3.156	3-5/32	80.2	2.940		.076	+ .007	.108	2.920		.093		.070		59.0	3.88	3.78
VSH-325	3.250	3-1/4	82.5	3.026		.076	- .000	.112	3.006		.093		.070	± .002	62.0	3.93	3.83
VSH-334	3.346	3-11/32	85.0	3.112		.075		.117	3.092		.093		.069		64.0	4.02	3.92
VSH-343	3.438	3-7/16	87.3	3.199		.075		.119	3.179		.093		.069		66.0	4.12	4.01
VSH-350	3.500	3-1/2	88.9	3.257		.091		.121	3.237		.109		.084		72.0	4.16	4.05
VSH-354	3.543	-	90.0	3.297	+ .000	.091		.123	3.277		.109		.084		73.0	4.25	4.14
VSH-362	3.625	3-5/8	92.1	3.372	- .006	.090		.126	3.352	+ .020	.109		.083		76.0	4.33	4.21
VSH-368	3.688	3-11/16	93.7	3.430	.006*	.090		.129	3.410	- .030	.109	± .003	.083		80.0	4.39	4.27
VSH-375	3.750	3-3/4	95.2	3.488		.089		.131	3.468		.109		.082		83.0	4.52	4.40
VSH-387	3.875	3-7/8	98.4	3.604		.089		.135	3.584		.109		.082		88.0	4.62	4.49
VSH-393	3.938	3-15/16	100.0	3.662		.088		.138	3.642		.109		.081	± .0025	95.0	4.70	4.57
VSH-400	4.000	4	101.6	3.720		.088		.140	3.700		.109		.081		101.0	4.76	4.63
VSH-425	4.250	4-1/4	108.0	4.009		.094		.120	3.989		.109		.087		112.0	4.98	4.87
VSH-437	4.375	4-3/8	111.1	4.126		.094		.124	4.106		.109		.087		115.0	5.11	4.99
VSH-450	4.500	4-1/2	114.3	4.243		.094		.128	4.223		.109		.087		132.0	5.37	5.25
VSH-475	4.750	4-3/4	120.6	4.478		.092	+ .008	.136	4.458		.109		.085		113.0	5.62	5.49
VSH-500	5.000	5	127.0	4.712		.091	- .000	.144	4.692		.109		.084		149.0	5.87	5.74
VSH-525	5.250	5-1/4	133.3	4.947	+ .000	.105		.151	4.927		.125		.098		190.0	6.20	6.05
VSH-550	5.500	5-1/2	139.7	5.182	- .007	.104		.159	5.162	+ .020	.125	± .004	.097		201.0	6.45	6.30
VSH-575	5.750	5-3/4	146.0	5.416	.006*	.103		.167	5.396	- .040	.125		.096		199.0	6.69	6.53
VSH-600	6.000	6	152.4	5.651		.102		.174	5.631		.125		.095		210.0	6.95	6.78
VSH-625	6.250	6-1/4	158.7	5.886		.132		.182	5.866		.156		.124		282.0	7.31	7.14
VSH-650	6.500	6-1/2	165.1	6.120		.131		.190	6.100	+ .020	.156		.123		330.0	7.67	7.49
VSH-675	6.750	6-3/4	171.4	6.355		.130		.197	6.335	- .050	.156		.122	± .003	356.0	8.06	7.87
VSH-700	7.000	7	177.8	6.590	+ .000	.129		.205	6.570		.156		.121		388.0	8.13	7.93
VSH-750	7.500	7-1/2	190.5	7.059	- .008	.158		.220	7.039		.187	± .005	.149		534.0	8.70	8.49
VSH-800	8.000	8	203.2	7.528	.006*	.157		.236	7.508		.187		.148		628.0	9.24	9.01
VSH-850	8.500	8-1/2	215.9	7.997		.154		.251	7.977	+ .020	.187		.145		700.0	9.79	9.54
VSH-900	9.000	9	228.6	8.465		.153		.267	8.445	- .060	.187		.144		757.0	10.60	10.34
VSH-950	9.500	9-1/2	241.3	8.935		.150		.282	8.915		.187		.141		820.0	11.10	10.82
VSH-1000	10.000	10	254.0	9.405		.148		.297	9.385		.187		.139		964.0	11.61	11.32

* F.I.M. (FULL INDICATOR MOVEMENT)-MAXIMUM ALLOWABLE DEVIATION OF CONCENTRICITY BETWEEN GROOVE AND SHAFT.

***FOR PLATED RINGS ADD .002" TO THE LISTED MAXIMUM THICKNESS. MAXIMUM RING THICKNESS WILL BE A MINIMUM OF .0002" LESS THAN THE LISTED GROOVE WIDTH (W) MINIMUM.

HARDNESS RANGES: STAINLESS STEEL RINGS (PH 15-7MO)

RING TYPE	SIZE RANGE	SCALE	ROCKWELL HARDNESS
VSH	All	C	44-51



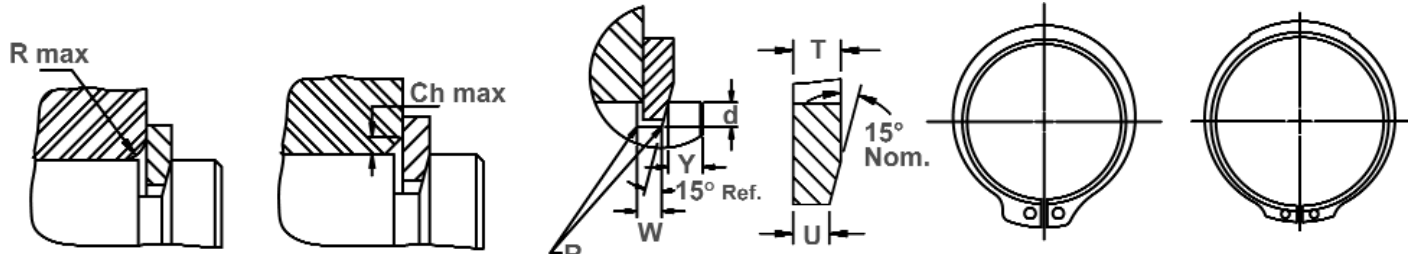

Maximum Corner Radius & Chamfer

Exploded Groove Profile & Edge Margin
Maximum bottom radii (R), .005 for ring sizes -100 thru -200; .010 for ring sizes -206 thru -1000

Asymmetrical Design
Manufacturer's Option

Alternate Lug Design
Manufacturer's Option
For Larger Sizes

RING NO.	ALLOWABLE CORNER RADII & CHAMFERS		MAX. LOAD W/ R MAX OR CH MAX (IN LBS.)	EDGE MARGIN	END-PLAY TAKE-UP	LUG HEIGHT	MAXIMUM SECTION		MINIMUM SECTION		HOLE DIAMETER		GAGING DIA.	THRUST LD. (LBS.) SQR. CORNER ABUTMENT		
	R max	Ch max					Pr	Y	In.	H	Tol.	S max		Tol.	S min	Tol.
VSH-312	.120	.072	7350	.159	.014	.324		.272		.141		.125		3.439	34815	11700
VSH-315	.1205	.072	7350	.162	.0145	.324		.274		.143		.125		3.469	35119	11900
VSH-325	.123	.074	7350	.168	.015	.300		.300		.145		.125		3.571	36134	12700
VSH-334	.126	.076	7350	.175	.0155	.300		.300		.147		.125		3.669	37251	13600
VSH-343	.129	.077	7350	.178	.016	.300		.300		.148		.125		3.767	38266	14300
VSH-350	.122	.073	10500	.181	.016	.285		.285		.148		.125		3.821	45574	14800
VSH-354	.123	.074	10500	.184	.0165	.310	±.005	.310	±.008	.149	±.008	.125		3.866	46183	15200
VSH-362	.127	.076	10500	.189	.017	.310		.310		.153		.125	+ .015	3.956	47299	16300
VSH-368	.1295	.078	10500	.193	.017	.310		.310		.156		.125	- .002	4.026	48010	16500
VSH-375	.133	.080	10500	.196	.0175	.342		.342		.160		.125		4.098	48822	17200
VSH-387	.137	.082	10500	.202	.018	.342		.342		.163		.125		4.229	50446	18300
VSH-393	.137	.082	10500	.207	.0185	.342		.342		.163		.125		4.290	51359	19000
VSH-400	.135	.081	10500	.210	.019	.342		.342		.163		.125		4.350	52171	19600
VSH-425	.146	.088	10500	.180	.016	.342		.342		.176		.125		4.620	55419	18000
VSH-437	.146	.088	10500	.186	.017	.342		.342		.181		.125		4.740	57043	19000
VSH-450	.102	.061	10500	.192	.017	.405		.405		.185		.125		4.920	58667	20200
VSH-475	.115	.069	10500	.204	.018	.405		.405		.136		.125		5.060	61915	22700
VSH-500	.165	.099	10500	.216	.019	.405	±.008	.405	±.010	.194	±.010	.156		5.410	65163	25400
VSH-525	.169	.101	13500	.226	.020	.435		.435		.211		.156		5.670	78460	28000
VSH-550	.175	.105	13500	.238	.021	.435		.390		.209		.156		5.940	82215	30800
VSH-575	.184	.110	13500	.250	.022	.435		.435		.220		.156		6.210	85971	33800
VSH-600	.143	.086	13500	.261	.023	.435		.435		.171		.156		6.380	89625	37000
VSH-625	.148	.089	21000	.273	.024	.485		.485		.176		.156		6.650	116522	40000
VSH-650	.191	.114	21000	.285	.025	.485		.485		.236		.156	+ .020	6.980	121191	43500
VSH-675	.200	.120	21000	.295	.026	.515		.515		.246		.187	- .005	7.260	125860	47000
VSH-700	.208	.125	21000	.307	.027	.515		.515		.256		.187		7.520	130529	50500
VSH-750	.220	.132	30000	.330	.029	.545	±.012	.545	±.015	.277	±.015	.187		8.060	167678	58000
VSH-800	.235	.141	30000	.354	.032	.560		.560		.294		.187		8.590	178843	66500
VSH-850	.250	.150	30000	.376	.034	.580		.580		.314		.187		9.130	190008	75000
VSH-900	.267	.160	30000	.400	.036	.735		.609		.333		.187		9.670	201173	86000
VSH-950	.281	.168	30000	.423	.038	.735		.642		.350		.187		10.200	212338	94500
VSH-1000	.294	.176	30000	.445	.040	.735		.675		.367		.187		10.730	223503	105000

† BASED ON HOUSINGS/SHAFTS MADE OF COLD ROLLED STEEL. FOR AN EXPLANATION OF FORMULAS USED TO DERIVE THRUST LOAD AND OTHER PERFORMANCE DATA, CONTACT THE ROTOR CLIP ENGINEERING DEPARTMENT.

HARDNESS RANGES: CARBON STEEL RINGS (SAE 1060-1090)

RING TYPE	SIZE RANGE	SCALE	ROCKWELL HARDNESS
VSH	100-102	C	47-53
	106-343	C	47-52
	350-700	C	44-51
	725-1000	C	40-47

HARDNESS RANGES: BERYLLIUM COPPER RINGS

RING TYPE	SIZE RANGE	SCALE	ROCKWELL HARDNESS
VSH	100-102	30N	56.5-62
	106+	C	37-43





E Shaft Rings

Radially Assembled, External 'E'

Perhaps the most popular and widely used radial retaining ring is the "E" (so named because it is shaped like the letter "E".) Three prongs make contact with the bottom of the groove and provide a shoulder for effective retention of assemblies.

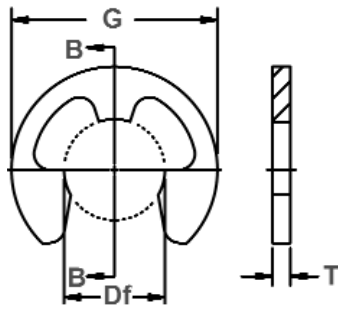

Free Diameter & Ring Measurements
With Section B-B

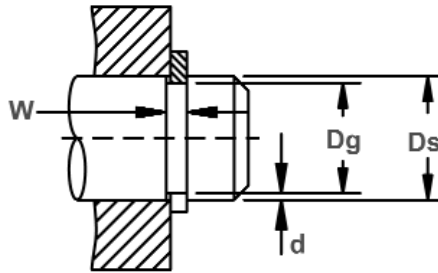

Shaft Diameter &
Groove Dimensions

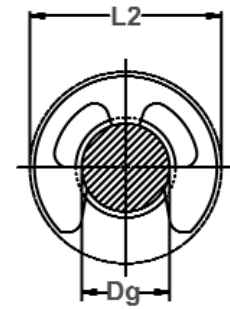

Clearance Diameter
Installed In Groove

RING NO.	SHAFT DIAMETER			GROOVE SIZE			RING SIZE & WEIGHT					CLEARANCE DIA.		THRUST LD. (lbs.)			
				DIAMETER		WIDTH	DEPTH	FREE DIAMETER		THICKNESS***		Weight Per 1000 pcs.	Free outside dia. REF.	Installed in groove	Sqr. corner abutment		
	Ds DEC	Ds FRAC	Ds mm	Dg	Tol.	W	Tol.	d	Df	Tol.	T				Tol.	G	L2
**E-4	.040	-	1.0	.026		.012		.007	.025		.010		.009	.079	.090	13	6
E-6	.062	1/16	1.6	.052		.012		.005	.051	+ .001	.010	± .001	.030	.156	.165	20	7
SE-6	.062	1/16	1.6	.052		.012		.005	.051	- .003	.010		.028	.140	.150	20	7
YE-6	.062	1/16	1.6	.052	+ .002	.023		.005	.051		.020		.094	.187	.200	41	7
SE-9	.094	3/32	2.4	.074	- .000	.020	+ .002	.010	.069	+ .002-.003	.015		.10	.230	.245	46	20
E-9	.094	3/32	2.4	.074	*.0015	.020	- .000	.010	.073		.015		.058	.187	.200	46	20
SE-11	.110	7/64	2.8	.079		.020		.015	.076		.015		.31	.375	.390	61	40
SE-12	.125	1/8	3.2	.095		.029		.015	.094		.025		.12	.214	.225	110	45
E-12	.125	1/8	3.2	.095		.020		.015	.094		.015		.087	.230	.240	66	45
SE-14	.140	9/64	3.6	.102		.020		.019	.100		.015		.060	.203	.215	76	60
YE-14	.140	9/64	3.6	.110		.020		.015	.108		.015		.10	.250	.265	76	45
E-14	.140	9/64	3.6	.105		.029		.017	.102	+ .001	.025		.21	.270	.285	173	60
SE-15	.156	5/32	4.0	.118		.046		.019	.116	- .003	.042		.76	.375	.390	300	70
E-15	.156	5/32	4.0	.116	+ .002	.029		.020	.114		.025		.21	.282	.295	178	75
SE-17	.172	11/64	4.4	.127	- .000	.029		.022	.125		.025		.24	.312	.325	183	90
SE-18	.188	3/16	4.8	.125	*.002	.029		.031	.122		.025		.45	.375	.39	203	135
YE-18	.188	3/16	4.8	.147		.029		.020	.145		.025	± .002	.70	.470	.485	193	90
ZE-18	.188	3/16	4.8	.125		.029		.031	.122		.025		1.05	.550	.565	203	135
E-18	.188	3/16	4.8	.147		.029		.020	.145		.025		.29	.335	.35	193	90
SE-21	.219	7/32	5.6	.188		.029		.015	.185		.025		.47	.437	.45	228	75
E-25	.250	1/4	6.3	.210		.029		.020	.207		.025		.76	.527	.54	259	115
SE-31	.312	5/16	7.9	.250		.029	+ .003	.031	.243		.025		.57	.500	.52	330	225
YE-31	.312	5/16	7.9	.250		.029	- .000	.031	.243		.025		1.220	.670	.685	325	220
SE-37	.375	3/8	9.5	.306		.039		.034	.303	+ .002	.035		1.050	.567	.587	680	300
E-37	.375	3/8	9.5	.303	+ .003	.039		.036	.300	- .004	.035		1.5	.660	.68	700	315
E-43	.438	7/16	11.1	.343	- .000	.039		.047	.337		.035		1.5	.687	.71	842	480
SE-43	.438	7/16	11.1	.380	*.004	.039		.029	.375		.035		1.0	.600	.62	812	280
E-50	.500	1/2	12.7	.396		.046		.052	.392		.042		2.5	.800	.82	1127	600
E-62	.625	5/8	15.9	.485		.046		.070	.480		.042		3.2	.940	.96	1441	1050
SE-74	.750	3/4	19.0	.625		.056		.062	.616	+ .003	.050		4.3	1.000	1.02	1979	1100
E-75	.750	3/4	19.0	.580		.056		.085	.574	- .005	.050		5.8	1.120	1.14	2030	1500
E-87	.875	7/8	22.2	.675		.056		.100	.668		.050		7.6	1.300	1.32	2385	2050
SE-98	.984	63/64	25.0	.835		.056		.074	.822		.050		9.2	1.500	1.53	2639	1750
SE-98	1.000	1	25.4	.835		.056		.082	.822		.050		9.2	1.500	1.53	2690	1900
SE-118	1.188	1-3/16	30.2	1.079	+ .005	.068	+ .004	.054	1.066	+ .006	.062	± .003	11.3	1.626	1.67	3501	1500
SE-137	1.375	1-3/8	34.9	1.230	- .000 * .005	.068	- .000	.072	1.213	- .010	.062		15.4	1.875	1.92	4162	2350

LISTED GROOVE WIDTH (W) MINIMUM.

* F.I.M. (FULL INDICATOR MOVEMENT)- MAXIMUM ALLOWABLE DEVIATION OF CONCENTRICITY BETWEEN GROOVE AND SHAFT.

** AVAILABLE IN BERYLLIUM COPPER ONLY.

† BASED ON GROOVES MADE OF COLD ROLLED STEEL. FOR AN EXPLANATION OF FORMULAS USED TO DERIVE THRUST LOAD AND OTHER PERFORMANCE DATA CONTACT THE ROTOR CLIP ENGINEERING DEPARTMENT.

*** FOR PLATED RINGS, ADD .002" TO THE LISTED MAXIMUM THICKNESS. MAXIMUM THICKNESS WILL BE A MINIMUM OF .0002" LESS THAN THE LISTED GROOVE WIDTH (W) MINIMUM.

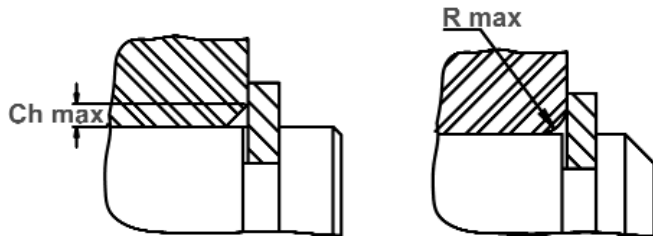

Maximum Corner Radius & Chamfer

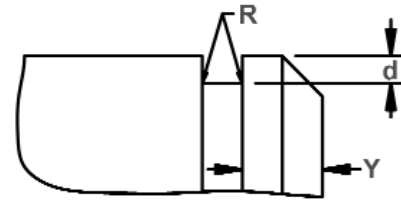

Exploded Groove Profile & Edge Margin (Y)
Maximum bottom radii (R), Sharp corners
for rings 4 thru 6; .005 For sizes SE9 thru 25; .010
For sizes SE-31 thru SE-43; .015 For sizes 50 thru SE-137

RING NO.	ALLOWABLE CORNER RADII & CHAMFERS		MAX LOAD w/ R max or Ch max (in lbs.)	EDGE MARGIN	R.P.M. LIMITS Standard material
	R max	Ch max			
**E-4	.015	.010	13	.014	40000
E-6	.030	.020	20	.010	40000
SE-6	.030	.020	20	.010	40000
YE-6	.035	.025	40	.010	40000
SE-9	.053	.040	45	.020	36000
E-9	.040	.030	45	.020	36000
SE-11	.080	.060	60	.030	35000
SE-12	.040	.030	108	.030	35000
E-12	.040	.030	65	.030	35000
SE-14	.029	.022	75	.038	32000
YE-14	.040	.030	75	.030	32000
E-14	.060	.045	170	.034	32000
SE-15	.080	.060	250	.038	31000
E-15	.060	.045	175	.040	31000
SE-17	.060	.045	180	.044	30000
SE-18	.060	.045	200	.062	30000
YE-18	.060	.045	190	.040	25000
ZE-18	.060	.045	200	.062	18000
E-18	.060	.045	190	.040	30000
SE-21	.060	.045	225	.030	26000
E-25	.060	.045	255	.040	25000
SE-31	.060	.045	325	.062	22000
YE-31	.060	.045	320	.062	15000
SE-37	.060	.045	680	.068	20000
E-37	.065	.050	690	.072	20000
E-43	.065	.050	830	.094	16500
SE-43	.050	.035	800	.058	16500
E-50	.080	.060	1110	.104	14000
E-62	.080	.060	1420	.140	12000
SE-74	.057	.042	1900	.124	11000
E-75	.085	.065	2000	.170	10500
E-87	.085	.065	2350	.200	9000
SE-98	.085	.065	2700	.148	6500
SE-98	.077	.057	2700	.164	6500
SE-118	.090	.070	3450	.108	5500
SE-137	.090	.070	4100	.144	4000

LARGER SIZES MAY BE AVAILABLE UPON REQUEST.

HARDNESS RANGES: STAINLESS STEEL RINGS (PH 15-7MO)

RING TYPE	SIZE RANGE	SCALE	ROCKWELL HARDNESS
E All	E6-SE6	15N	82.5-86*
	YE6-YE14	15N	82.5-86
	E14-SE31	30N	63-69.5
	E37+	C	44-51

HARDNESS RANGES: BERYLLIUM COPPER RINGS

RING TYPE	SIZE RANGE	SCALE	ROCKWELL HARDNESS
E All	E4-SE6	15N	79-82*
	YE6-YE14	15N	79-82
	E14-SE31	30N	56.5-62
	E37+	C	37-43

HARDNESS RANGES: CARBON STEEL RINGS (SAE 1060-1090)

RING TYPE	SIZE RANGE	SCALE	ROCKWELL HARDNESS
E All	E6-SE6	15N	84.5-87*
	YE6-YE14	15N	84.5-87
	E14-SE31	30N	66.5-71
	E37+	C	47-52

*HARDNESS CAN NOT BE CHECKED WITH ANY DEGREE OF ACCURACY DIRECTLY ON THESE RINGS.





RE Shaft Rings

Radially Assembled, External Reinforced 'E'

The RE retaining ring is a reinforced version of the E ring, which will accommodate higher thrust loadings and RPM. RE rings function in the same groove as regular E rings, so that you can change from one to the other without re-engineering the application.

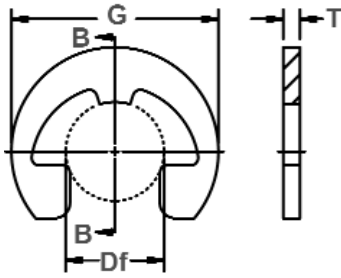

Free Diameter & Ring Measurements with Section B-B

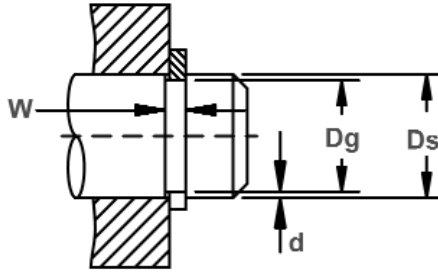

Shaft Diameter & Groove Dimensions

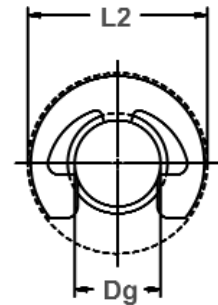

Clearance Diameter Installed In Groove

RING NO.	SHAFT DIAMETER			GROOVE SIZE			RING SIZE & WEIGHT				CLEARANCE DIA.		i THRUST LD. (lbs.)				
				DIAMETER		WIDTH	DEPTH	FREE DIAMETER		THICKNESS***		Weight. Per 1000 Pcs.	Free Out-Side Dia.	Installed In Groove	Sqr. Corner Abutment	Ring Safety factor of 3	Groove Safety factor of 2
	Ds DEC	Ds FRACT	Ds mm	Dg	Tol.	W	Tol.	d	Df	Tol.	T						
RE-9	.094	3/32	2.4	.074	+.002	.020	+.002	.010	.072	+.001	.015	±.002	.07	.206	.219	51	13
RE-12	.125	1/8	3.2	.095	-.000	.020	-.000	.015	.093	-.003	.015		.13	.270	.283	76	25
RE-15	.156	5/32	4.0	.116	.0015*	.029	+.003	.020	.113	+.002-.003	.025		.31	.335	.35	152	40
RE-18	.188	3/16	4.8	.147	.029	.020		.143	.025	.39	.375		.39	183	50		
RE-21	.219	7/32	5.6	.188	±.002	.029		.015	.182	±.003	.025		.54	.446	.46	223	50
RE-25	.250	1/4	6.3	.210	.002*	.029	.020	.204	.025	.71	.516		.53	254	75		
RE-31	.312	5/16	7.9	.250	±.003	.029	+.003	.031	.242	.025	.85		.588	.61	305	135	
RE-37	.375	3/8	9.5	.303	.003*	.039	-.000	.036	.292	.035	1.5		.660	.68	528	190	
RE-43	.438	7/16	11.1	.343	.039	.047	.332	.035	1.9	.746	.77		609	285			
RE-50	.500	1/2	12.7	.396	±.003	.046	.052	.385	±.004	.042	3.2		.810	.83	832	360	
RE-56	.562	9/16	14.3	.437	.004*	.046	.062	.430	.042	3.5	.870		.89	944	480		

*F.I.M. (FULL INDICATOR MOVEMENT)-MAXIMUM ALLOWABLE DEVIATION OF CONCENTRICITY BETWEEN GROOVE AND SHAFT.

i BASED ON HOUSINGS/SHAFTS MADE OF COLD ROLLED STEEL. FOR AN EXPLANATION OF FORMULAS USED TO DERIVE THRUST LOAD AND OTHER PERFORMANCE DATA, CONTACT THE ROTOR CLIP ENGINEERING DEPT.

*** FOR PLATED RINGS, ADD .002" TO THE LISTED MAXIMUM THICKNESS. MAXIMUM RING THICKNESS WILL BE A MINIMUM OF .0002" LESS THAN THE LISTED GROOVE WIDTH (W) MINIMUM.

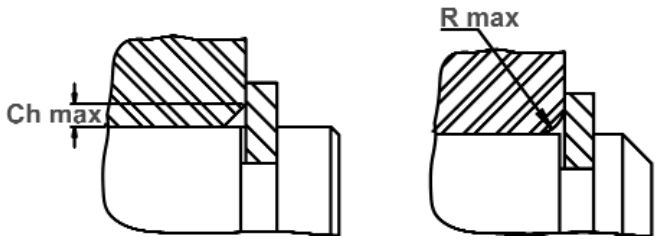

Maximum Corner Radius & Chamfer

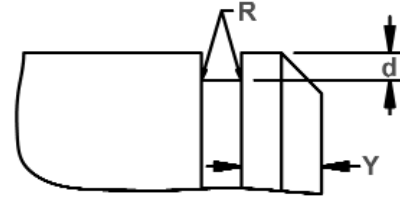

Exploded Groove Profile & Edge Margin (Y)
Maximum bottom radii (R), .005 for ring sizes -9 thru -25; .010 for ring sizes -31 thru -43; .015 for ring sizes -50 thru -56

RING NO.	ALLOWABLE CORNER RADII & CHAMFERS		MAX. LOAD W/ R MAX or Ch max (in lbs.)	EDGE MARGIN		R.P.M. LIMITS Standard Material
	R max	Ch max		P'r	Y	
RE-9	.045	.033	50	.020	90000	
RE-12	.045	.033	75	.030	70000	
RE-15	.065	.050	150	.040	60000	
RE-18	.065	.050	180	.040	50000	
RE-21	.065	.050	220	.031	43000	
RE-25	.065	.050	250	.040	38000	
RE-31	.070	.055	300	.062	32000	
RE-37	.070	.055	520	.072	28000	
RE-43	.070	.055	600	.094	24000	
RE-50	.080	.060	820	.104	20000	
RE-56	.080	.060	930	.124	17000	

NOTE: CONTACT ROTOR CLIP FOR AVAILABILITY OF SIZES LISTED. LARGER SIZES MAY BE AVAILABLE UPON REQUEST.

HARDNESS RANGES: STAINLESS STEEL RINGS (PH 15-7MO)

RING TYPE	SIZE RANGE	SCALE	ROCKWELL HARDNESS
RE	9&12	15N	82.5-86
	15-31	30N	63-69.5
	37+	C	44-51

HARDNESS RANGES: BERYLLIUM COPPER RINGS

RING TYPE	SIZE RANGE	SCALE	ROCKWELL HARDNESS
RE	9&12	15N	77-82
	15-31	30N	54-62
	37+	C	34-43

HARDNESS RANGES: CARBON STEEL RINGS (SAE 1060-1090)

RING TYPE	SIZE RANGE	SCALE	ROCKWELL HARDNESS
RE	9&12	15N	84.5-87
	15-31	30N	66.5-71
	37+	C	47-52



C Shaft Rings

Radially Assembled, External Crescent

Ideal for low clearance applications where radial installation is preferred.

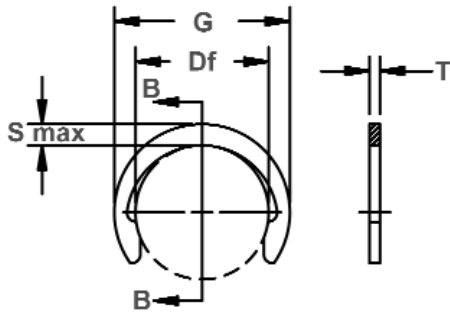

Free Diameter & Ring Measurements with Section B-B

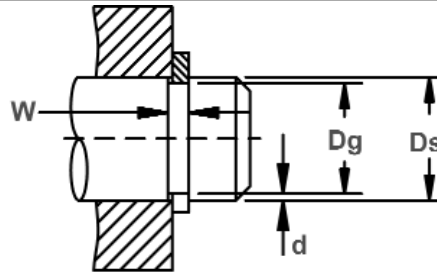

Shaft Diameter & Groove Dimensions

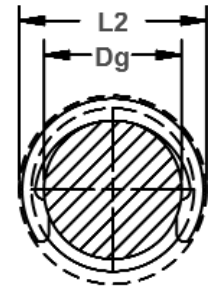

Clearance Diameter Installed In Groove

RING NO.	SHAFT DIAMETER			GROOVE SIZE			RING SIZE & WEIGHT				CLEARANCE DIA.			THRUST LD. (lbs.)			
				DIAMETER		WIDTH	DEPTH	FREE DIAMETER		THICKNESS**		Wght. Per 1000 Pcs.	Free outside dia. REF.	Re-leased in groove	Sqr. Corner Abutment		
	Ds DEC	Ds FRACT	Ds mm	Dg	Tol.	W	Tol.	d	Df	Tol.	T				Tol.	lbs.	G
C-12	.125	1/8	3.2	.106	±.0015	.020	+.002	.0095	.102	+.002	.015		.030	.165	.18	86	45
C-15	.156	5/32	4.0	.135	*.0015	.020	-.000	.0105	.131	-.004	.015		.052	.205	.22	102	55
C-18	.188	3/16	4.8	.165		.020		.011	.161		.015		.062	.244	.25	132	70
C-21	.219	7/32	5.6	.193	±.002*.0015	.029		.013	.187		.025		.120	.275	.29	264	100
C-23	.236	15/64	6.0	.208	±.002*.002	.029		.014	.203		.025		.15	.295	.31	284	115
C-25	.250	1/4	6.4	.220		.029		.015	.211	+.003	.025		.157	.311	.33	294	130
C-28	.281	9/32	7.1	.247		.029		.017	.242	-.005	.025		.19	.346	.36	335	165
C-31	.312	5/16	7.9	.276	±.002	.029		.018	.270		.025		.226	.376	.39	376	200
C-37	.375	3/8	9.5	.335	*.002	.029		.020	.328		.025		.300	.448	.47	447	270
C-40	.406	13/32	10.3	.364		.029		.021	.359		.025		.352	.486	.50	487	300
C-43	.438	7/16	11.1	.393		.029		.022	.386		.025		.359	.517	.53	528	350
C-50	.500	1/2	12.7	.450		.039	+.003	.025	.441	±.006	.035	±.002	.671	.581	.60	842	450
C-56	.562	9/16	14.3	.507		.039	-.000	.028	.497		.035		.710	.653	.67	944	550
C-62	.625	5/8	15.9	.563		.039		.031	.553		.035		.937	.715	.74	1045	700
C-68	.688	11/16	17.5	.619	±.003	.046		.034	.608		.042		1.3	.784	.80	1726	800
C-75	.750	3/4	19.0	.676	*.004	.046		.037	.665		.042		1.5	.845	.87	1878	1000
C-81	.812	13/16	20.6	.732		.046		.040	.721	±.007	.042		1.7	.915	.94	2040	1150
C-87	.875	7/8	22.2	.789		.046		.043	.777		.042		2.0	.991	1.01	2202	1300
C-93	.938	15/16	23.8	.843		.046		.047	.830		.042		2.3	1.058	1.08	2355	1550
C-100	1.000	1	25.4	.900		.046		.050	.887		.042		2.7	1.130	1.15	2517	1800
C-112	1.125	1-1/8	28.6	1.013		.056		.056	.997		.050		4.0	1.267	1.30	3370	2200
C-125	1.250	1-1/4	31.7	1.126	±.004	.056		.062	1.110	±.008	.050		5.1	1.415	1.44	3735	2700
C-137	1.375	1-3/8	34.9	1.237	*.005	.056	+.004	.069	1.220		.050		6.1	1.555	1.58	4111	3350
C-150	1.500	1-1/2	38.1	1.350		.056	-.000	.075	1.331		.050		7.6	1.691	1.72	4486	4000
C-162	1.625	1-5/8	41.3	1.483	±.005	.068		.071	1.463		.062		11.0	1.853	1.88	5506	4650
C-175	1.750	1-3/4	44.4	1.576	*.005	.068		.087	1.555	±.010	.062	±.003	12.9	1.975	2.01	6526	5300
C-200	2.000	2	50.8	1.800		.068		.100	1.777		.062		16.2	2.257	2.30	7410	7000

*F.I.M.(FULL INDICATOR MOVEMENT)-MAXIMUM ALLOWABLE DEVIATION OF CONCENTRICITY BETWEEN GROOVE AND SHAFT.

† BASED ON HOUSINGS/SHAFTS MADE OF COLD ROLLED STEEL. FOR AN EXPLANATION OF FORMULAS USED TO DERIVE THRUST LOAD AND OTHER PERFORMANCE DATA, CONTACT THE ROTOR CLIP ENGINEERING DEPT.

** FOR PLATED RINGS ADD .002" TO THE LISTED MAXIMUM THICKNESS. MAXIMUM RING THICKNESS WILL BE A MINIMUM OF .0002" LESS THAN THE LISTED GROOVE WIDTH (W) MINIMUM.

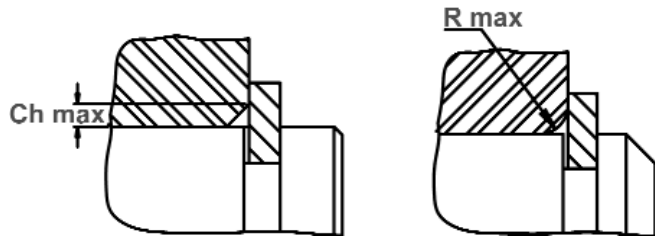

Maximum Corner Radius & Chamfer

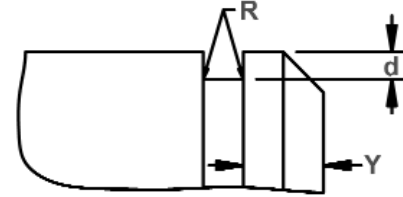

Enlarged Groove Profile & Edge Margin (Y)
Maximum bottom radii (R), .005 For rings sizes -12 thru -43; .010 For ring sizes -46 thru -100; .015 For sizes -112 thru -200

RING NO.	MAXIMUM SECTION		ALLOWABLE CORNER RADII & CHAMFERS		MAX LOAD w/ R max or Ch max (in lbs.)	EDGE MARGIN		R.P.M. LIMITS Standard material
	S max	Tol.	R max	Ch max		P'r	Y	
C-12	.031	± .003	.014	.011	85	.020	80000	
C-15	.037		.018	.014	100	.020	75000	
C-18	.042		.021	.016	110	.022	73000	
C-21	.044		.021	.016	260	.026	71000	
C-23	.046	± .004	.022	.017	275	.028	62000	
C-25	.050		.023	.018	290	.030	60000	
C-28	.051		.021	.016	310	.034	56000	
C-31	.053		.024	.018	310	.036	52000	
C-37	.060		.026	.020	310	.040	43000	
C-40	.063	± .005	.027	.021	310	.042	40000	
C-43	.065		.029	.022	310	.044	31000	
C-50	.070		.030	.023	610	.050	25000	
C-56	.078		.033	.025	610	.056	22000	
C-62	.081		.033	.025	610	.062	20000	
C-68	.086		.034	.026	880	.068	18500	
C-75	.090		.036	.027	880	.074	17500	
C-81	.097		.038	.029	880	.080	16000	
C-87	.105		.040	.031	880	.086	15000	
C-93	.112		.043	.033	880	.094	14000	
C-100	.120	.046	.035	880	.100	12500		
C-112	.135	± .007	.052	.040	1250	.112	11500	
C-125	.150		.057	.044	1250	.124	10500	
C-137	.165		.062	.048	1250	.138	9500	
C-150	.180		.069	.053	1250	.150	8500	
C-162	.195		.075	.058	1920	.162	8000	
C-175	.210		.081	.062	1920	.174	7500	
C-200	.240		.091	.070	1920	.200	6000	

LARGER SIZES MAY BE AVAILABLE UPON REQUEST.

HARDNESS RANGES: STAINLESS STEEL RINGS (PH 15-7MO)

RING TYPE	SIZE RANGE	SCALE	ROCKWELL HARDNESS
C	12-18	15N	82.5-86*
	21-81	30N	63-69.5
	87+	C	44-51

HARDNESS RANGES: BERYLLIUM COPPER RINGS

RING TYPE	SIZE RANGE	SCALE	ROCKWELL HARDNESS
C	12-62	15N	77-82*
	68-81	30N	54-62
	87+	C	34-43

HARDNESS RANGES: CARBON STEEL RINGS (SAE 1060-1090)

RING TYPE	SIZE RANGE	SCALE	ROCKWELL HARDNESS
C	12-18	15N	86-88.5*
	21-43	30N	67.5-72
	50-81	30N	66-71
	87+	C	47-52

*HARDNESS CAN NOT BE CHECKED WITH ANY DEGREE OF ACCURACY DIRECTLY ON THESE RINGS.



LC Shaft Rings

Radially Assembled, External Interlocking

The LC ring is produced in two identical halves. The ends interlock into a groove on a shaft and, once assembled, are dynamically balanced. As a result, they are particularly effective at retaining assemblies with extremely high rotational speeds.

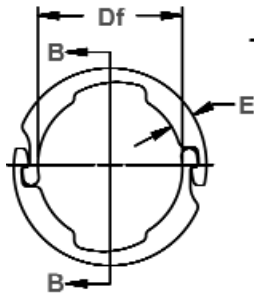

Free Diameter & Ring Measurements with Section B-B

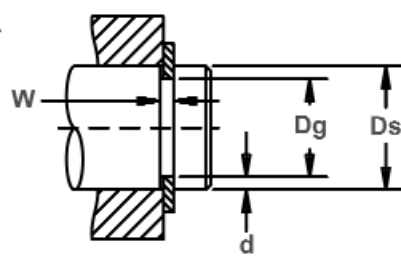

Shaft Diameter & Groove Dimensions



Plier Notch Design
(Call for additional information)

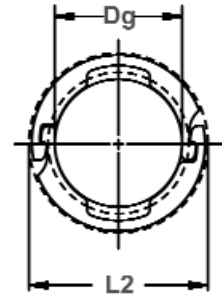

Clearance Diameter Installed in Groove

RING NO.	SHAFT DIAMETER			GROOVE SIZE			RING SIZE & WEIGHT				CLEARANCE	i Thrust Id. (lbs.) Sq. Corner Abutment				
				DIAMETER		WIDTH	DEPTH	FREE DIAMETER		THICKNESS***		Weight Per 1000 Rings (2 Halves)	Installed in groove	Ring Safety factor of 3	Groove Safety factor of 2	
	Ds DEC	Ds FRACT	Ds mm	Dg	Tol.	W	Tol.	d	Df	Tol.	T					Tol.
LC-46	.469	15/32	11.9	.419	±.0015	.039		.025	.414		.035		1.36	.640	2030	620
LC-50	.500	1/2	12.7	.464	.004*	.039		.018	.459		.035		1.50	.680	2132	480
LC-59	.594	19/32	15.1	.544		.039	+ .003	.025	.538	±.002	.035		1.74	.766	2538	790
LC-62	.625	5/8	15.9	.575		.039	- .000	.025	.569		.035		1.82	.797	2690	830
LC-66	.669	-	17.0	.599		.046		.035	.593		.042		3.1	.886	3400	1250
LC-75	.750	3/4	19.0	.680	±.002	.046		.035	.673	±.003	.042	±.002	3.5	.967	3806	1400
LC-78	.781	25/32	19.8	.711	*.004	.046		.035	.703		.042		3.6	.998	4009	1450
LC-87	.875	7/8	22.2	.805		.046		.035	.796		.042		3.8	1.092	4466	1600
LC-98	.984	63/64	25.0	.872	±.003	.056		.056	.863		.050		7.3	1.273	5938	2900
LC-98	1.000	1	25.4	.872	*.004	.056		.064	.863		.050		7.3	1.273	5938	3400
LC-112	1.125	1-1/8	28.6	1.013		.056		.056	1.002		.050		7.9	1.42	6801	3350
LC-118	1.188	1-3/16	30.2	1.075	±.003	.056	+ .004	.056	1.064	±.004	.050		8.5	1.48	7207	3500
LC-125	1.250	1-1/4	31.7	1.138	*.005	.056	- .000	.056	1.126		.050		8.9	1.54	7562	3700
LC-137	1.375	1-3/8	34.9	1.263		.056		.056	1.250		.050		9.6	1.67	8323	4100
LC-150	1.500	1-1/2	38.1	1.388		.056		.056	1.374		.050		10.6	1.79	9084	4450
LC-156	1.562	1-9/16	39.7	1.427		.068		.068	1.412		.062		16.4	1.91	11926	5650
LC-162	1.625	1-5/8	41.3	1.489		.068		.068	1.474		.062		17.5	1.97	12434	5850
LC-175	1.750	1-3/4	44.4	1.614	±.005	.068		.068	1.597	±.005	.062		18.4	2.10	13398	6300
LC-175	1.772	-	45.0	1.614	*.005	.068		.078	1.597		.062		18.4	2.10	13398	7350
LC-187	1.875	1-7/8	47.6	1.739		.068		.068	1.721		.062		20.8	2.22	14312	6800
LC-196	1.969	1-31/32	50.0	1.797		.086		.086	1.779		.078		31.0	2.37	18524	9000
LC-200	2.000	2	50.8	1.828		.086		.086	1.809		.078		31.6	2.40	18778	9150
LC-212	2.125	2-1/8	54.0	1.953	±.005	.086	+ .005	.086	1.933	±.006	.078	±.003	34.2	2.52	19996	9700
LC-212	2.156	2-5/32	54.8	1.953	*.006	.086	- .000	.101	1.933		.078		34.2	2.52	19996	11500
LC-225	2.250	2-1/4	57.1	2.078		.086		.086	2.057		.078		37.3	2.65	21112	10300
LC-237	2.375	2-3/8	60.3	2.203		.086		.086	2.180		.078		38.9	2.77	22330	10800
LC-250	2.500	2-1/2	63.5	2.328		.086		.086	2.304		.078		39.7	2.90	23548	11400
LC-262	2.625	2-5/8	66.7	2.453		.086		.086	2.428		.078		43.9	3.02	24665	12000
LC-275	2.750	2-3/4	69.8	2.544		.103		.103	2.518		.093		63.2	3.25	30653	15000
LC-287	2.875	2-7/8	73.0	2.669	±.006	.103		.103	2.642	±.008	.093		68.4	3.37	32074	15700
LC-300	3.000	3	76.2	2.794	*.006	.103		.103	2.754		.093		70.4	3.50	33495	16400
LC-325	3.250	3-1/4	82.5	3.044		.103		.103	3.013		.093		77.6	3.75	36286	17800
LC-337	3.375	3-3/8	85.7	3.145		.120		.115	3.114		.109		94.0	3.99	44153	20600

*F.I.M. (FULL INDICATOR MOVEMENT) - MAXIMUM ALLOWABLE DEVIATION OF CONCENTRICITY BETWEEN GROOVE AND SHAFT.

i BASED ON HOUSINGS/SHAFTS MADE OF COLD ROLLED STEEL. FOR AN EXPLANATION OF FORMULAS USED TO DERIVE THRUST LOAD AND OTHER PERFORMANCE DATA, CONTACT THE ROTOR CLIP ENGINEERING DEPT.

***FOR PLATED RINGS, ADD .002" TO THE LISTED MAXIMUM THICKNESS. MAXIMUM RING THICKNESS WILL BE A MINIMUM OF .0002" LESS THAN THE LISTED GROOVE WIDTH (W) MINIMUM.

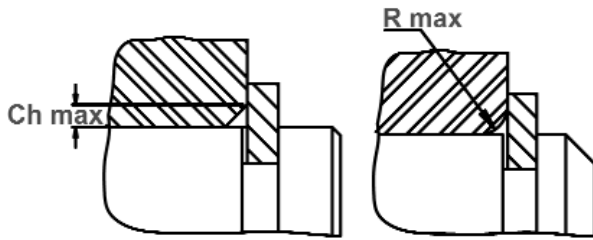

Maximum Corner Radius & Chamfer

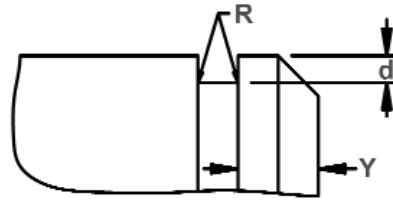

Exploded Groove Profile & Edge Margin (Y)
 Maximum bottom radii (R): .005 for ring sizes -46 thru -98; .010 for ring sizes -112 thru -200; .015 for ring sizes -212 thru -337.

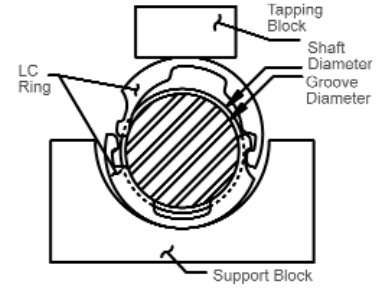

V-Block Assembly

RING NO.	MAXIMUM SECTION		ALLOWABLE CORNER RADII & CHAMFERS		MAX. LOAD W/R max or Ch max (lbs)	EDGE MARGIN Y	R.P.M. LIMITS Standard Material
	E	Tol.	R max	Ch max			
LC-46	.105	± .005	.052	.040	610	.075	50000
LC-50	.105		.052	.040	610	.054	50000
LC-59	.105		.052	.040	610	.075	46000
LC-62	.105	± .006	.052	.040	610	.075	45000
LC-66	.135		.065	.050	880	.105	43000
LC-75	.135		.065	.050	880	.105	40000
LC-78	.135		.065	.050	880	.105	39000
LC-87	.135		.065	.050	880	.105	35000
LC-98	.188		.086	.066	1250	.168	31000
LC-98	.188		.081	.062	1250	.192	30000
LC-112	.188		.086	.066	1250	.168	28000
LC-118	.188		.086	.066	1250	.168	27000
LC-125	.188		.086	.066	1250	.168	26000
LC-137	.188	.086	.066	1250	.168	24000	
LC-150	.188	± .007	.086	.066	1250	.168	22000
LC-156	.222		.100	.077	1900	.204	21000
LC-162	.222		.100	.077	1900	.204	20500
LC-175	.222		.100	.077	1900	.204	19000
LC-175	.222		.094	.072	1900	.234	19000
LC-187	.222		.100	.077	1900	.204	17000
LC-196	.262		.114	.088	3050	.258	15500
LC-200	.262		.114	.088	3050	.258	15000
LC-212	.262		.114	.088	3050	.258	14300
LC-212	.262		.104	.080	3050	.303	14300
LC-225	.262	.114	.088	3050	.258	13500	
LC-237	.262	.114	.088	3050	.258	12800	
LC-250	.262	.114	.088	3050	.258	12000	
LC-262	.262	.114	.088	3050	.258	11300	
LC-275	.323	± .008	.143	.110	4300	.309	10500
LC-287	.323		.143	.110	4300	.309	9800
LC-300	.329		.143	.110	4300	.309	9000
LC-325	.325		.144	.111	4300	.309	7500
LC-337	.395		.182	.140	5950	.345	6800

LARGER SIZES MAY BE AVAILABLE UPON REQUEST.

HARDNESS RANGES: STAINLESS STEEL RINGS (PH 15-7MO)

RING TYPE	SIZE RANGE	SCALE	ROCKWELL HARDNESS
LC	All	C	44-51

HARDNESS RANGES: BERYLLIUM COPPER RINGS

RING TYPE	SIZE RANGE	SCALE	ROCKWELL HARDNESS
LC	46-62	30N	56.5-62
	66 & over	C	37-43

HARDNESS RANGES: CARBON STEEL RINGS (SAE 1060-1090)

RING TYPE	SIZE RANGE	SCALE	ROCKWELL HARDNESS
LC	46-62	30N	65.5-70.5
	66 & over	C	47-52





PO/POL Shaft Rings

Radially Assembled, External Poodle

The PO ring features wide "ears" (resembling those of a poodle dog, thus the name) which offer extra retention surface against the retained part. PO rings also come in thinner sizes as a standard series of rings known as POL.

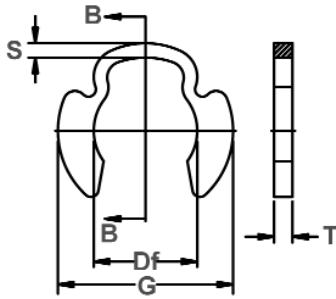

Free Diameter & Ring Measurements
With Section B-B

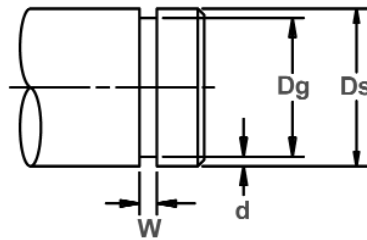

Shaft Diameter &
Groove Dimensions

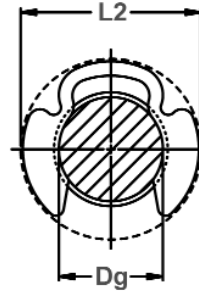

Clearance Diameter
Installed In Groove

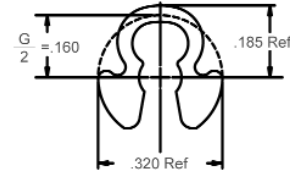

PO-15 & POL-15
Only

RING NO.	SHAFT DIAMETER			GROOVE SIZE						RING SIZE & WEIGHT				CLR. DIA. Installed in groove	i THRUST LD. (lbs.) Sqr. Corner Abutment			
				DIAMETER		WIDTH	DEPTH	FREE DIAMETER	THICKNESS***		Weight Per 1000 Pcs.	Pr	Pg					
	Ds DEC	Ds FRACT	Ds mm	Dg	Tol.	F.I.M*	W	Tol.	d ref.	Df				Tol.	T	Tol.	L2	Pr
PO-15	.156	5/32	4.0	.120	±.004	.002	.039			.018	.110		.035		.42	.39	457	110
PO-18	.188	3/16	4.8	.148	±.005	.002	.039			.020	.140	±.003	.035		.63	.42	609	130
PO-25	.250	1/4	6.4	.210		.003	.039			.020	.188		.035		.84	.52	914	200
PO-31	.312	5/16	7.9	.272	±.006	.003	.046	+ .006		.020	.250		.042	±.002	1.46	.63	1320	250
PO-37	.375	3/8	9.5	.331		.003	.046			.022	.312		.042		1.92	.72	1573	300
PO-43	.438	7/16	11.1	.390		.003	.056			.024	.375	±.004	.050		2.66	.79	2233	400
PO-50	.500	1/2	12.7	.440	±.008	.004	.056			.030	.406		.050		3.30	.89	2538	600
PO-62	.625	5/8	15.9	.531		.004	.056			.047	.500	±.005	.050		4.65	1.03	3045	1100
PO-75	.750	3/4	19.0	.632		.004	.068			.059	.594		.062		6.35	1.17	4669	1600
PO-100	1.000	1	25.4	.860	±.010	.004	.086	+ .008		.070	.812	±.006	.078	±.003	12.65	1.51	7613	2600
PO-125	1.250	1 -1/4	31.8	1.090		.006	.103			.080	1.032		.093		25.20	1.90	11165	3500
PO-150	1.500	1 -1/2	38.1	1.317		.008	.120			.091	1.250	±.008	.109		36.3	2.18	15530	4800
PO-175	1.750	1-3/4	44.4	1.480	±.015	.010	.139	+ .010		.135	1.406	±.010	.125	±.004	53.0	2.45	20808	8200
PO-200	2.000	2	50.8	1.730		.012	.139			.135	1.625	±.015	.125		69.2	2.83	23853	9450
POL-15	.156	5/32	4.0	.120	±.004	.002	.029			.018	.110		.025		.30	.39	325	110
POL-18	.188	3/16	4.8	.148	±.005	.002	.029			.020	.140		.025		.45	.42	436	130
POL-25	.250	1/4	6.4	.210		.003	.029			.020	.188		.025		.60	.52	650	200
POL-31	.312	5/16	7.9	.272	±.006	.003	.029	+ .006		.020	.250	±.003	.025	±.002	.87	.63	792	250
POL-37	.375	3/8	9.5	.331		.003	.039			.022	.312		.035		1.60	.72	1320	300
POL-43	.438	7/16	11.1	.390		.003	.039			.024	.375	±.004	.035		1.86	.79	1878	400
POL-50	.500	1/2	12.7	.440	±.008	.004	.046			.030	.406		.042		2.77	.89	2132	600
POL-62	.625	5/8	15.9	.531		.004	.046			.047	.500	±.005	.042		3.65	1.03	2538	1100
POL-75	.750	3/4	19.0	.632	±.010	.004	.056	+ .008		.059	.594		.050		5.35	1.17	3756	1600
POL-100	1.000	1	25.4	.860		.004	.056			.070	.812	±.006	.050		8.60	1.51	4872	2600

*F.I.M. (FULL INDICATOR MOVEMENT)- MAXIMUM ALLOWABLE DEVIATION OF CONCENTRICITY BETWEEN GROOVE AND SHAFT.

i BASED ON HOUSINGS/SHAFTS MADE OF COLD ROLLED STEEL. FOR AN EXPLANATION OF FORMULAS USED TO DERIVE THRUST LOAD AND OTHER PERFORMANCE DATA, CONTACT THE ROTOR CLIP ENGINEERING DEPARTMENT.

***FOR PLATED RINGS, ADD .002" TO THE LISTED MAXIMUM THICKNESS. MAXIMUM RING THICKNESS WILL BE A MINIMUM OF .0002" LESS THAN THE LISTED GROOVE WIDTH (W) MINIMUM.

NOTE: THIS GROUP CONTAINS ALTERNATE THICKNESS VALUES (COLUMN "T"). OTHER PARAMETERS SUCH AS WIDTH OF GROOVE ("W") AND THRUST LOAD "Pr" ALSO DIFFER FROM STANDARD VERSIONS. PLEASE TAKE THIS INTO CONSIDERATION WHEN SELECTING A PO RING FOR YOUR DESIGN.

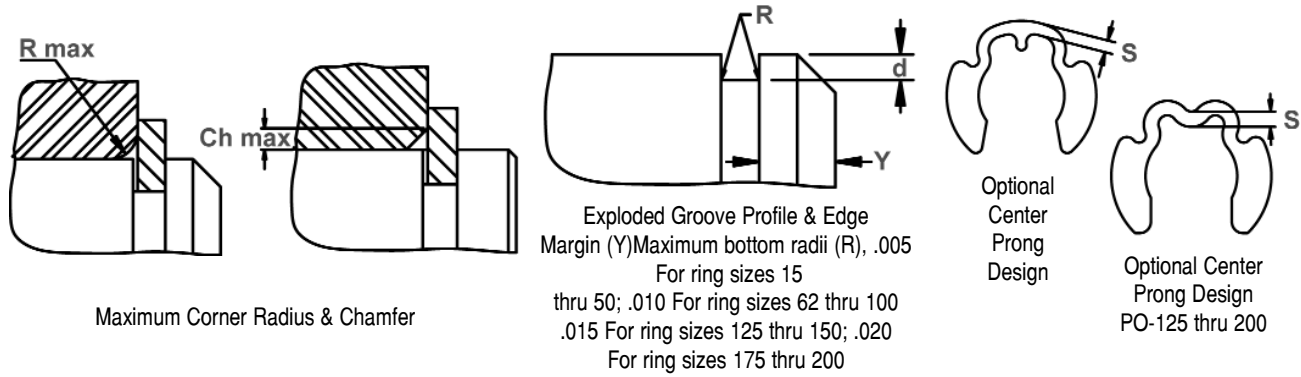

Maximum Corner Radius & Chamfer

RING NO.	OUTSIDE DIA.	LARGE SECT.	ALLOWABLE CORNER RADII & CHAMFERS		MAX LOAD W/ R max or Ch max in (lbs.)	EDGE MARGIN	R.P.M. LIMITS Steel Rings
			G ref.	S			
PO-15	.320	.042	.050	.040	250	.036	80000
PO-18	.400	.048	.050	.040	270	.040	80000
PO-25	.482	.058	.050	.040	310	.040	65000
PO-31	.588	.074	.065	.050	400	.040	65000
PO-37	.680	.081	.065	.050	430	.044	65000
PO-43	.752	.081	.080	.060	600	.048	60000
PO-50	.826	.097	.080	.060	630	.060	50000
PO-62	.966	.086	.080	.060	720	.094	45000
PO-75	1.095	.095	.085	.065	1000	.118	38000
PO-100	1.415	.113	.090	.065	1800	.140	25000
PO-125	1.800	.180	.090	.065	2750	.160	11000
PO-150	2.050	.208	.10	.07	3800	.182	9000
PO-175	2.300	.235	.12	.09	5100	.270	7000
PO-200	2.650	.250	.13	.10	5100	.270	5000
POL-15	**	.042	.050	.040	130	.036	80000
POL-18	.400	.048	.050	.040	140	.040	80000
POL-25	.482	.058	.050	.040	150	.040	65000
POL-31	.588	.074	.050	.040	150	.040	65000
POL-37	.680	.081	.065	.050	200	.044	65000
POL-43	.752	.081	.065	.050	300	.048	60000
POL-50	.826	.097	.080	.060	450	.060	50000
POL-62	.966	.086	.080	.060	500	.094	45000
POL-75	1.095	.095	.090	.070	650	.118	38000
POL-100	1.415	.113	.090	.070	740	.140	25000

LARGER SIZES MAY BE AVAILABLE UPON REQUEST.

SEE NOTE ON PREVIOUS PAGE.

HARDNESS RANGES: STAINLESS STEEL RINGS (PH 15-7MO)

RING TYPE	SIZE RANGE	SCALE	ROCKWELL HARDNESS
PO	All	C	44-51

HARDNESS RANGES: BERYLLIUM COPPER RINGS

RING TYPE	SIZE RANGE	SCALE	ROCKWELL HARDNESS
PO	15-25	30N	54-62
	31+	C	34-43

HARDNESS RANGES: CARBON STEEL RINGS (SAE 1060-1090)

RING TYPE	SIZE RANGE	SCALE	ROCKWELL HARDNESS
PO	All	C	47-53

HARDNESS RANGES: STAINLESS STEEL RINGS (PH 15-7MO)

RING TYPE	SIZE RANGE	SCALE	ROCKWELL HARDNESS
POL	15-31	30N	63-69.5
	37+	C	44-51

HARDNESS RANGES: BERYLLIUM COPPER RINGS

RING TYPE	SIZE RANGE	SCALE	ROCKWELL HARDNESS
POL	15-43	30N	54-62
	50+	C	34-43

HARDNESS RANGES: CARBON STEEL RINGS (SAE 1060-1090)

RING TYPE	SIZE RANGE	SCALE	ROCKWELL HARDNESS
POL	15-31	30N	65.5-71
	37+	C	47-53





BE Shaft Rings

Radially Assembled, External Bowed 'E'

Compensating for accumulated tolerances is what a BE "Bowed" retaining ring is designed to do on a shaft. Once snapped into the groove, bowed rings exert a force or a "preload" on the retained parts for the range specified.

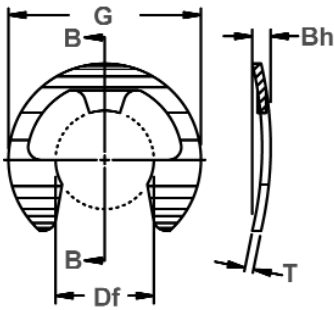

Free Diameter & Ring Measurements
With Section B-B

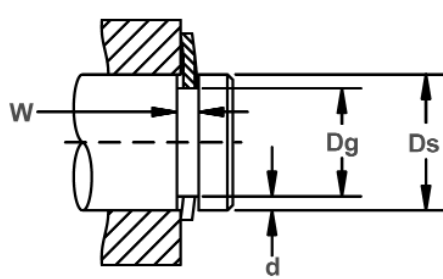

Shaft Diameter &
Groove Dimensions

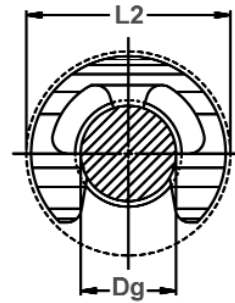

Clearance Diameter
Installed In Groove

RING NO.	SHAFT DIAMETER			GROOVE SIZE			RING SIZE AND WEIGHT					CLEARANCE DIAMETER					
				DIAMETER		WIDTH	DEPTH	FREE DIAMETER	THICKNESS***		BOW HEIGHT		Weight Per 1000 Pcs.	Out-side dia. REF.	Installed in groove		
	Ds DEC	Ds FRACT	Ds mm	Dg	Tol.	W	Tol.		d	Df	Tol.	T				Tol.	Bh min.
BSE-11	.110	7/64	2.8	.079	+ .002	.022		.015	.076		.010		.025	.035	.20	.375	.390
BE-12	.125	1/8	3.2	.095	-.000	.022		.015	.094		.010	± .001	.025	.035	.06	.230	.240
BSE-14	.140	9/64	3.6	.102	.0015*	.019		.019	.100		.010		.022	.032	.040	.203	.215
BE-14	.140	9/64	3.6	.105		.025		.017	.102		.015		.028	.038	.13	.270	.285
BE-15	.156	5/32	4.0	.116		.027		.020	.114	+ .001	.015		.030	.040	.13	.282	.295
BSE-17	.172	11/64	4.4	.127	+ .002	.029		.022	.125	-.003	.015		.032	.042	.16	.312	.325
BE-18	.188	3/16	4.8	.147	-.000	.030		.020	.145		.015		.033	.043	.17	.335	.35
BSE-18	.188	3/16	4.8	.125	.002*	.035	+ .003	.031	.122		.015		.038	.048	.27	.375	.39
BSE-21	.219	7/32	5.6	.188		.040	-.000	.015	.185		.015		.043	.058	.28	.437	.45
BE-25	.250	1/4	6.3	.210		.047		.020	.207		.025		.050	.065	.76	.527	.54
BSE-31	.312	5/16	7.9	.250		.047		.031	.243	+ .002	.025	± .002	.050	.065	.57	.500	.52
BE-37	.375	3/8	9.5	.303		.060		.036	.300	-.004	.035		.060	.076	1.5	.660	.68
BE-43	.438	7/16	11.1	.343		.060		.047	.337		.035		.060	.076	1.5	.687	.71
BSE-43	.438	7/16	11.1	.380	+ .003	.057		.029	.375		.035		.060	.076	1.0	.600	.62
BE-50	.500	1/2	12.7	.396	-.000	.073		.052	.392		.042		.075	.093	2.5	.800	.82
BE-62	.625	5/8	15.9	.485	.004*	.077		.070	.480		.042		.080	.098	3.2	.940	.96
BSE-74	.744	-	18.9	.625		.085		.060	.616		.050		.090	.110	4.3	1.000	1.02
BSE-74	.750	3/4	19.0	.625		.085		.062	.616		.050		.090	.110	4.3	1.000	1.02
BE-75	.750	3/4	19.0	.580		.085		.085	.574	+ .003	.050		.090	.110	5.8	1.120	1.14
BE-87	.875	7/8	22.2	.675		.085		.100	.668	-.005	.050		.090	.110	7.6	1.300	1.32
BSE-98	.984	63/64	25	.835		.085		.074	.822		.050		.088	.112	9.38	1.500	1.530

*F.I.M. (FULL INDICATOR MOVEMENT)-MAXIMUM ALLOWABLE DEVIATION OF CONCENTRICITY BETWEEN GROOVE AND SHAFT.

***FOR PLATED RINGS, ADD .002" TO THE LISTED MAXIMUM THICKNESS.

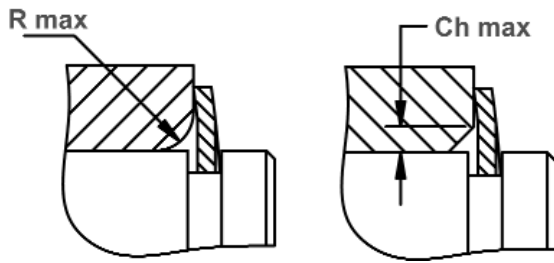

Maximum Corner Radius & Chamfer

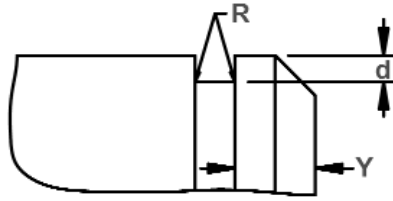

Exploded Groove Profile & Edge Margin (Y)
Maximum bottom radii (R), .005 For ring sizes BSE-11 Thru -25; 010 For ring sizes BSE-31 Thru BSE-43; .015 For ring sizes 50 and over.

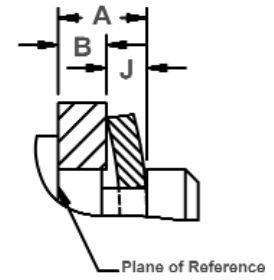

Outer Groove Wall Location
A max=B min + J max
A min=B max + J min

RING NO.	DISTANCE Outer groove wall to face of retained part		TAKE-UP Resilient take-up of tolerances a & b	FORCE Needed to flatten rings	ALLOWABLE CORNER RADII & CHAMFERS		MAX. LOAD w/ R max or Ch max (in lbs.)	EDGE MARGIN	R.P.M LIMITS Standard materials	THRUST LD. (lbs.) Sqr. corner abutment	
					J min	J max				J max-J min	lbs.
	BSE-11	.017	.022	.005	19	.080	.060	60	.030	35000	61
BE-12	.017	.022	.005	8	.040	.030	43	.030	35000	44	45
BSE-14	.014	.018	.004	6	.029	.022	50	.038	32000	51	60
BE-14	.020	.023	.003	16	.060	.045	75	.034	32000	76	60
BE-15	.022	.027	.005	15	.060	.045	80	.040	31000	81	75
BSE-17	.023	.029	.006	14	.060	.045	90	.044	30000	91	90
BE-18	.023	.030	.007	12	.060	.045	95	.040	30000	96	90
BSE-18	.026	.034	.008	16	.060	.045	100	.062	30000	102	135
BSE-21	.029	.039	.010	12	.060	.045	115	.030	26000	117	75
BE-25	.036	.046	.010	35	.060	.045	255	.040	25000	259	115
BSE-31	.036	.046	.010	30	.060	.045	325	.062	22000	330	225
BE-37	.045	.055	.010	55	.065	.050	690	.072	20000	700	315
BE-43	.045	.055	.010	50	.065	.050	830	.094	16500	842	480
BSE-43	.045	.055	.010	65	.050	.035	800	.058	16500	812	280
BE-50	.056	.070	.014	90	.080	.060	1110	.104	14000	1127	600
BE-62	.061	.075	.014	85	.080	.060	1420	.140	12000	1441	1050
BSE-74	.069	.085	.016	110	.057	.062	1900	.118	11000	1940	1050
BSE-74	.069	.085	.016	110	.042	.062	1900	.124	11000	1979	1100
BE-75	.069	.085	.016	110	.085	.065	2000	.170	10500	2030	1500
BE-87	.069	.085	.016	120	.085	.065	2350	.200	9000	2385	2050
BSE-98	.067	.083	.016	110	.085	.065	2700	.148	6500	2600	1750

i BASED ON HOUSINGS/SHAFTS MADE OF COLD ROLLED STEEL. FOR AN EXPLANATION OF FORMULAS USED TO DERIVE THRUST LOAD AND OTHER PERFORMANCE DATA PLEASE CONTACT THE ROTOR CLIP ENGINEERING DEPARTMENT. LARGER SIZES MAY BE AVAILABLE UPON REQUEST.

HARDNESS RANGES: STAINLESS STEEL RINGS (PH 15-7MO)

RING TYPE	SIZE RANGE	SCALE	ROCKWELL HARDNESS
BE	BE12-BSE14	15N	82.5-86*
	BSE11, BE14-BSE21	15N	82.5-86
	BE25-BSE31	30N	63-69.5
	BE37+	C	44-51

*HARDNESS CAN NOT BE CHECKED WITH ANY DEGREE OF ACCURACY DIRECTLY ON THESE RINGS.

HARDNESS RANGES: CARBON STEEL RINGS (SAE 1060-1090)

RING TYPE	SIZE RANGE	SCALE	ROCKWELL HARDNESS
BE All	BSE12-BSE14	15N	84.5-87*
	BSE11, BE14-BSE21	15N	84.5-87
	BE25-BSE31	30N	66.5-71
	BE37+	C	47-52

*HARDNESS CAN NOT BE CHECKED WITH ANY DEGREE OF ACCURACY DIRECTLY ON THESE RINGS.

HARDNESS RANGES: BERYLLIUM COPPER RINGS

RING TYPE	SIZE RANGE	SCALE	ROCKWELL HARDNESS
BE	BE12-BSE14	15N	77-82*
	BSE11, BE14-BSE21	15N	77-82
	BE25&BSE31	30N	54-62
	BE37+	C	34-43

*HARDNESS CAN NOT BE CHECKED WITH ANY DEGREE OF ACCURACY DIRECTLY ON THESE RINGS.





EL Shaft Rings

Radially Assembled, External Bowed Locking

Another variation of a bowed E ring is the EL. In addition to the bowed design for eliminating "play" in an assembly, it also features two prongs, which extend from the inner circumference to the open end locking the ring firmly into place.

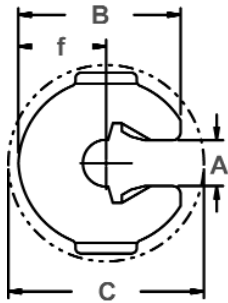

Ring Measurements

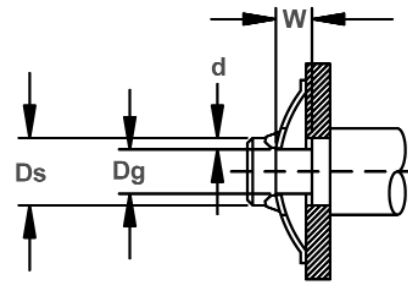
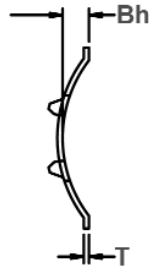

Shaft Diameter & Groove Dimensions

RING NO.	SHAFT DIAMETER			GROOVE SIZE			RING SIZE & WEIGHT						CLR. DIA.	THRUST LOAD (lbs.sq. corner abutment)						
				DIAMETER	WIDTH	DEPTH	LENGTH	THICKNESS***	BOW HEIGHT	GAP	WGHT. PER 1000 Pcs.	Released In Groove	Ring Safety Factor Of 3	Groove Safety Factor Of 3						
	DEC	Tol.	FRACT	Dg	Tol.	W	TOL.	d	B	Tol.	T	Tol.	Bh	Tol.	A	Tol.	LBS.	C	Pr	Pg
EL-9	.092		3/32	.061	±.001	.035		.016	.307		.010		.050		.063		.23	.370	80	35
EL-12	.125	±.002	1/8	.082	±.0015	.035		.021	.307		.010	±.001	.050		.086	±.004	.19	.370	102	60
EL-18	.188		3/16	.124	±.002	.045	+ .005	.032	.390	±.010	.015		.060	±.010	.130		.47	.480	203	140
EL-25	.250	±.003	1/4	.165		.055	-.000	.042	.500		.015	±.002	.070		.172	±.005	.77	.620	305	250
EL-31	.312		5/16	.228	±.003	.080		.042	.620		.015		.095		.234		1.3	.790	355	300
EL-37	.375		3/8	.270		.095		.052	.740		.020		.130		.280		2.2	.940	555	450

† BASED ON HOUSINGS/SHAFTS MADE OF COLD ROLLED STEEL. FOR AN EXPLANATION OF FORMULAS USED TO DERIVE THRUST LOAD AND OTHER PERFORMANCE DATA CONTACT THE ROTOR CLIP ENGINEERING DEPARTMENT. LARGER SIZES MAY BE AVAILABLE UPON REQUEST.

***For plated rings, add .002" to the listed maximum thickness.

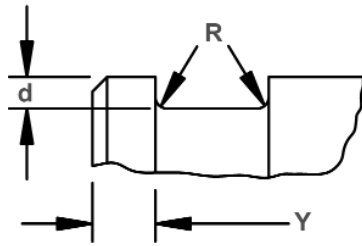

Exploded Groove Profile & Edge Margin (Y)
Maximum bottom radii (R) .005 for ring sizes
-9 thru -25; .010 for ring sizes -31 thru -37

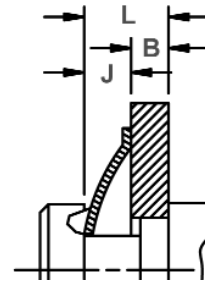

Outer Groove Wall Location
 $L_{max} = B_{min} + J_{max}$
 $L_{min} = B_{max} + J_{min}$

RING NO.	DISTANCE		RESILIENT TAKE-UP OF TOLERANCES OF A&B	FORCE NEEDED TO FLATTEN RINGS	APPROX. AV RESILIENT RES. (lbs) WITHIN J MAX. & J MIN		f REF.	EDGE MARGIN Y
	OUTER GROOVE WALL TO FACE OF RETAINED PART				LBS.	IN-STALLED		
	J MIN.	J MAX.	J MAX. - J MIN.					
EL-9	.030	.038	.008	30	9	3.5	.166	.031
EL-12	.030	.040	.010	30	8	3.0	.166	.043
EL-18	.039	.049	.010	60	20	5.5	.213	.064
EL-25	.045	.060	.015	60	15	7.0	.280	.085
EL-31	.070	.085	.015	60	6	4.0	.360	.084
EL-37	.080	.105	.025	80	19	7.0	.427	.105

HARDNESS RANGES: STAINLESS STEEL RINGS (PH 15-7MO)

RING TYPE	SIZE RANGE	SCALE	ROCKWELL HARDNESS
EL	9&12	15N	82.5-86*
	18-31	15N	82.5-86
	37	30N	63-69.5

HARDNESS RANGES: BERYLLIUM COPPER RINGS

RING TYPE	SIZE RANGE	SCALE	ROCKWELL HARDNESS
EL	9&12	15N	77-82*
	18-37	15N	77-82

HARDNESS RANGES: CARBON STEEL RINGS (SAE 1060-1090)

RING TYPE	SIZE RANGE	SCALE	ROCKWELL HARDNESS
EL	9&12	15N	83.5-86*
	18&25	15N	83.5-86
	31&37	30N	65-69.5

*HARDNESS CAN NOT BE CHECKED WITH ANY DEGREE OF ACCURACY DIRECTLY ON THESE RINGS.



SHF Shaft Rings

External, Self-Locking Friction

The SHF ring resembles a regular SH ring except that it is designed to function on a shaft without a groove. The design of the ring causes it to exert significant gripping power uniformly on the shaft (except where the gap occurs.)

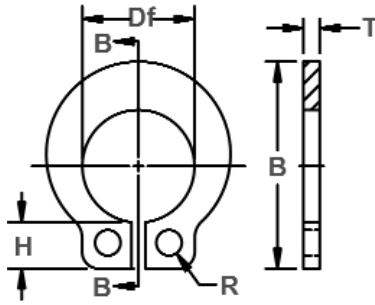

Free Diameter & Ring Measurements
With Section B-B

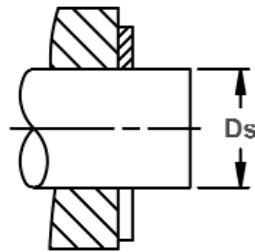

Without Groove

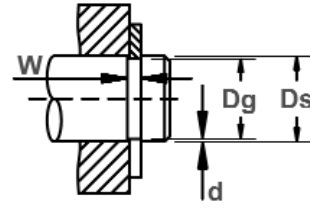

Optional Use in Groove
(Larger Sizes)

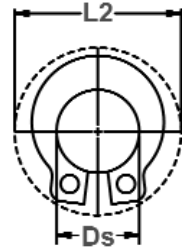

Clearance Diameter
Expanded Over Shaft

RING NO.	SHAFT DIAMETER				GROOVE SIZE			RING SIZE & WEIGHT				Weight Per 1000 Pcs.	CLEAR. Re-leas-ed over shaft	THRUST LD.(lbs.) Sqr. corner abutment								
					Dg	Tol.	W	Tol.	d	FREE DIAMETER				THICKNESS***		Allow-able load (lbs.)	Groove Safety factor of 2					
	FROM	TO	Ds FRACT	Ds mm						Df	Tol.	T	Tol.	Pr	Pg							
	Ds DEC	Ds	Ds	Ds	Dg	Tol.	W	Tol.	d	Df	Tol.	T	Tol.	lbs.	L2	Pr	Pg					
SHF-6	.058	.060	-	1.5	NOT RECOMMENDED FOR USE WITH GROOVES					.055	±.002	.015	±.002	.030	.21	5	NOT RECOMMENDED FOR USE WITH GROOVES					
SHF-7	.078	.080	5/64	2.0						.074		.025		.08	.24	8						
SHF-9	.092	.096	3/32	2.4						.089		.025		.10	.26	8						
SHF-12	.123	.127	1/8	3.2						.120		.025		.14	.33	10						
SHF-15	.154	.158	5/32	4.0						.150		.025		.30	.36	12						
SHF-18	.185	.189	3/16	4.8						.181		.035		.55	.44	20						
SHF-19	.195	.199	-	5.0						.187		.032		.45	.43	30						
SHF-23	.234	.238	15/64	6.0						.228		.041		.041	.041	.041		.035	.76	.48	22	70
SHF-25	.248	.252	1/4	6.3						.240		.041		.041	.041	.041		.035	.74	.49	23	90
SHF-31	.310	.316	5/16	7.9						.303		.048		.048	.048	.048		.042	1.39	.68	25	110
SHF-37	.373	.379	3/8	9.5	.361	.048	.048	.048	.048	.042	1.72	.74	31	180								
SHF-43	.434	.440	7/16	11.0	.419	.056	.056	.056	.056	.050	2.61	.81	41	290								
SHF-50	.497	.503	1/2	12.7	.478	.056	.056	.056	.056	.050	2.91	.90	46	390								
SHF-62	.622	.628	5/8	15.9	.599	.069	.069	.069	.069	.062	5.70	1.06	61	570								
SHF-75	.745	.755	3/4	19.0	.718	.069	.069	.069	.069	.062	6.88	1.32	66	850								

† VALUES SHOWN APPLY TO RINGS INSTALLED ON A SHAFT MADE OF LOW CARBON STEEL.

FOR AN EXPLANATION OF FORMULAS USED TO DERIVE THRUST LOAD AND OTHER PERFORMANCE DATA, CONTACT THE ROTOR CLIP ENGINEERING DEPARTMENT.

***FOR PLATED RINGS, ADD .002" TO THE LISTED MAXIMUM THICKNESS.

MAXIMUM RING THICKNESS (WHEN USED IN GROOVE) WILL BE A MINIMUM OF .0002" LESS THAN THE LISTED GROOVE WIDTH (W) MINIMUM.

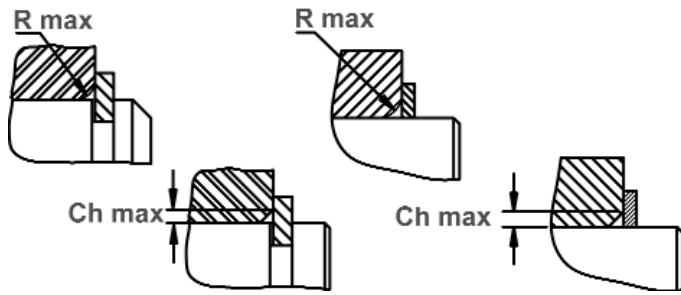

Maximum Corner Radius & Chamfer
(With Grooves)

Maximum Corner Radius & Chamfer
(Without Grooves)

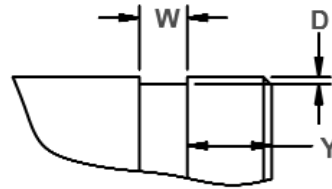

Exploded Groove Profile &
Edge Margin (Y)



Optional Lug Design

RING NO.	ALLOWABLE CORNER RADII & CHAMFERS		EDGE MARGIN	LUG		HOLE		RING HEIGHT	R.P.M. LIMITS Standard material		
	R max	Ch max	Y	H	Tol.	R	Tol.	B			
SHF-6	.025	.015	NOT RECOMMENDED FOR USE WITH GROOVES	.066	±.005	.035	±.004	.145	OVER 80000		
SHF-7	.036	.022		.071	±.003	.034		.184			
SHF-9	.042	.025		.074		.034	.207				
SHF-12	.054	.032		.078	.042	.268					
SHF-15	.059	.035		.078	.042	.307					
SHF-18	.063	.038		.097	.051	.364					
SHF-19	.064	.039		.104	±.008	.375					
SHF-23	.070	.042		.030	.098	±.003	.051	+.010		.422	
SHF-25	.072	.043		.030	.097	.051	.051	-.002		.437	77000
SHF-31	.080	.048		.030	.141	±.004	.078	+.015 -.002		.553	58000
SHF-37	.086	.051	.030	.141	.078		.620		51000		
SHF-43	.093	.056	.030	.151	.078		.701		44000		
SHF-50	.100	.060	.040	.158	.078		.768		40000		
SHF-62	.120	.072	.045	.180	.078		.948		32000		
SHF-75	.125	.075	.050	.233	.120		1.115		25000		

LARGER SIZES MAY BE AVAILABLE UPON REQUEST.

HARDNESS RANGES: STAINLESS STEEL RINGS (PH 15-7MO)

RING TYPE	SIZE RANGE	SCALE	ROCKWELL HARDNESS
SHF	9	15N	82.5-86
	12-23	30N	63-69.5
	25+	C	44-51

HARDNESS RANGES: BERYLLIUM COPPER RINGS

RING TYPE	SIZE RANGE	SCALE	ROCKWELL HARDNESS
SHF	9	15N	77-82
	12-23	30N	54-62
	25+	C	34-43

HARDNESS RANGES: CARBON STEEL RINGS (SAE 1060-1090)

RING TYPE	SIZE RANGE	SCALE	ROCKWELL HARDNESS
SHF	6-9	15N	83.5-86
	12-23	30N	65-69.5
	25+	C	46-51



RG Shaft Rings

External, Self-Locking Radial Grip

The RG makes indentations on either side of the groove once installed which significantly increases its holding power. It can also be installed directly against the face of the retained part, virtually eliminating end play.

(Note: this product works only on "soft" shafts.)

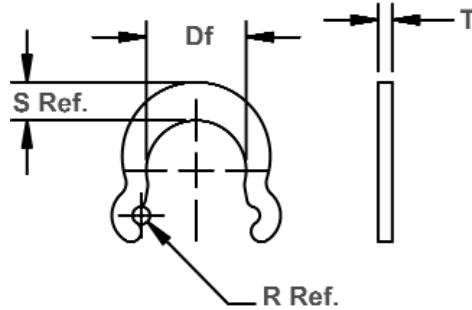

Free Diameter & Ring Measurements

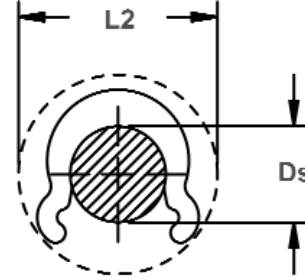

Clearance Diameter Installed On Shaft

RING NO.	SHAFT DIAMETER				RING SIZE & WEIGHT						CLEARANCE Installed on shaft	THRUST LOAD Allowable load (lbs.)	RPM LIMITS Standard Material	
					FREE DIAMETER		THICKNESS***		NOTCH DIA.	MAXIMUM SECTION				Weight Per 1000 Pcs.
	FROM	TO	Ds FRACT	Ds mm	Df	Tol.	T	TOL.			R Ref.	S Ref.	lbs.	
RG-9	.092	.096	3/32	2.4	.089	+.002	.025	± .002	.040	.045	.14	.30	8	OVER 80,000
RG-12	.123	.127	1/8	3.2	.119	-.003	.025		.040	.054	.19	.34	10	
RG-15	.154	.158	5/32	4.0	.149	+.002	.025		.040	.078	.27	.38	13	
RG-18	.185	.189	3/16	4.8	.179	-.004	.035		.048	.085	.45	.44	18	
RG-25	.248	.252	1/4	6.3	.238		.035		.048	.100	.74	.54	22	
RG-31	.310	.316	5/16	7.9	.298	+.003	.042		.052	.114	1.1	.66	32	
RG-37	.373	.379	3/8	9.5	.356	-.005	.042		.052	.130	1.5	.76	42	

† VALUES SHOWN APPLY TO RINGS INSTALLED ON A SHAFT MADE OF LOW CARBON STEEL.

FOR AN EXPLANATION OF FORMULAS USED TO DERIVE THRUST LOAD AND OTHER PERFORMANCE DATA, CONTACT THE ROTOR CLIP ENGINEERING DEPARTMENT.

***FOR PLATED RINGS, ADD .002" TO THE LISTED MAXIMUM THICKNESS.

HARDNESS RANGES: CARBON STEEL RINGS (SAE 1060-1090)

RING TYPE	SIZE RANGE	SCALE	ROCKWELL HARDNESS
RG	9-15	30N	65.8-70.2
	18-37	C	47-52

External, Self-Locking Push-On (Curved Rim)

This ring features an outer rim with a series of prongs protruding into the center. The ends create interference with the shaft when the ring is installed and a load introduced to the other side. The outer rim of the TX is curved which affords greater thrust load capacity and is easier to orient for assembly than the TY ring (next page.)

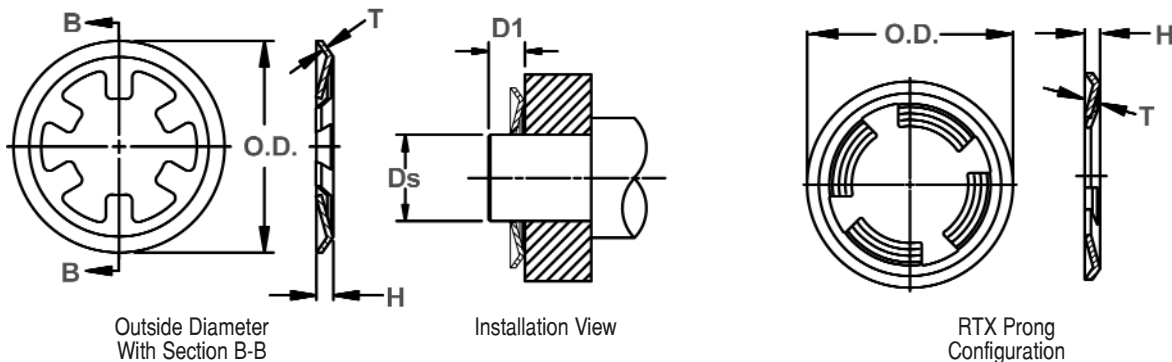

RING NO.	SHAFT DIAMETER				OUTSIDE DIAMETER		No. of prongs	*** RING HEIGHT		* THICKNESS **Standard		i Thrust Ld. @ Std. T	Wght. Per 1000 Pcs. @ Std. T	* Thick-ness Optional	i Thrust Ld. @ Opt. T	WEIGHT Per 1000 Pcs. @ Opt. T	Min. Distance Face of part to end of shaft
	Ds DEC		Ds FRACT	Ds mm	O.D.	Tol.		H	Tol.	T	Tol.						
	FROM	TO												T			
TX-9	.091	.097	3/32	2.39	.326	±.005	3	.029		.010	±.001	27	.16	.015	45	.25	.058
TX-12	.121	.129	1/8	3.17	.366		4	.029	±.005	.010		39	.19	±.002	57	.30	.058
TX-15	.152	.160	5/32	3.96	.397		4	.029		.010		46	.22		70	.35	.058
TX-18	.184	.192	3/16	4.77	.444		6	.031	±.007	.010	±.001	56	.27	.015 ±.002	85	.42	.062
TX-25	.246	.254	1/4	6.35	.522		6	.042		.015	±.002	112	.55	.010	58	.39	.074
TX-31	.308	.316	5/16	7.92	.584		8	.042	±.008	.015		112	.64	±.001	60	.44	.074
TX-37	.371	.379	3/8	9.53	.645		8	.042		.015		122	.74	.010 ±.001	65	.48	.074
RTX-37	.371	.379	3/8	9.53	.645		4	.047	±.010	.020		250	1.14	-	-	-	.074
TX-43	.432	.442	7/16	11.1	.737		10	.045	±.009	.015		122	.96	-	-	-	.090
TX-50	.495	.505	1/2	12.7	.828		10	.054		.015		122	1.27	-	-	-	.108
TX-56	.557	.567	9/16	14.27	.889	12	.054		.015	127		1.38	-	-	-	.108	
TX-62	.620	.630	5/8	15.88	.951	12	.054	±.010	.015	137		1.47	-	-	-	.108	
TX-75	.745	.755	3/4	19.05	1.076	14	.054		.015	142		1.65	-	-	-	.108	
TX-87	.870	.880	7/8	22.23	1.203	16	.054		.015	142		1.96	-	-	-	.108	
TX-100	.995	1.005	1	25.4	1.327	18	.054		.015	142	2.29	-	-	-	.108		
RTX-100	.995	1.005	1	25.4	1.327	6	.059		.020	600	3.30	-	-	-	.108		

*FOR PLATED RINGS ADD .002" TO MAXIMUM THICKNESS AND HEIGHT.

** STANDARD THICKNESS FOR STAINLESS STEEL IS AS FOLLOWS:TX-9-TX-37, .010"; TX-43-TX-100, .015".

*** FOR TX-9-TX-18 OPTIONAL THICKNESS (.015"), ADD .005" TO RING HEIGHT VALUES (H) SHOWN.

FOR TX-25-TX-37 OPTIONAL THICKNESS (.010), DEDUCT.005" FROM RING HEIGHT VALUES (H) SHOWN.

THRUST LOAD CAPACITY IF APPLICABLE TO PARTS MADE FROM CARBON SPRING STEEL AND STAINLESS STEEL MATERIALS ONLY.

HARDNESS RANGES: STAINLESS STEEL RINGS (PH 15-7MO)

RING TYPE	SIZE RANGE	SCALE	ROCKWELL HARDNESS
TX	All .010 Thick Rings	15N	82.5-86*
	All .015 Thick Rings	15N	82.5-86

HARDNESS RANGES: BERYLLIUM COPPER RINGS

RING TYPE	SIZE RANGE	SCALE	ROCKWELL HARDNESS
TX	All .010 Thick Rings	15N	77-82*
	All .015 Thick Rings	15N	77-82

HARDNESS RANGES: CARBON STEEL RINGS (SAE 1060-1090)

RING TYPE	SIZE RANGE	SCALE	ROCKWELL HARDNESS
TX	All .010 Thick Rings	15N	84-86*
	All .015 Thick Rings	15N	84-86

*HARDNESS CAN NOT BE CHECKED WITH ANY DEGREE OF ACCURACY DIRECTLY ON THESE RINGS.





TY Shaft Rings

External, Self-Locking Push-On (Flat Rim)

This ring features an outer rim with a series of prongs protruding into the center. The ends create interference with the shaft when the ring is installed and a load introduced to the other side. The outer rim of the TY is flat.

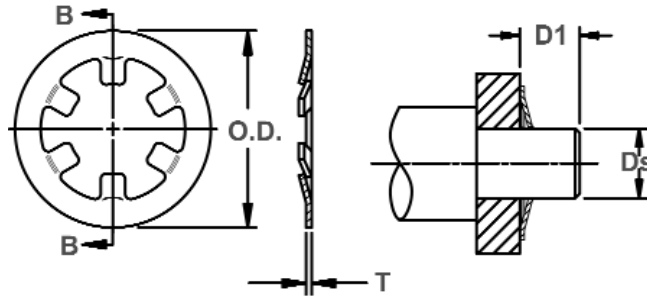

Outside Diameter
With Section B-B

Installation View

RING NO.	SHAFT DIAMETER				OUTSIDE DIAMETER		No. Of Prongs	THICKNESS*		î Thrust Load	WEIGHT Per 1000 Pcs.	Min. Distance Face of part to end of shaft
	Ds DEC-DEZ		Ds FRACT	Ds mm	O.D.	Tol.		T	Tol.			
	FROM	TO										
TY-9	.093	.095	3/32	2.39	.250	± .005	3	.010	± .001	13	.09	.040
TY-12	.124	.126	1/8	3.17	.325					4	20	.14
TY-15	.155	.157	5/32	3.96	.356		4	25	.17	.040		
TY-18	.187	.189	3/16	4.77	.387		6	35	.20	.040		
TY-21	.218	.220	7/32	5.56	.418		6	35	.21	.040		
TY-24	.239	.241	-	6.10	.460		6	.015	± .002	40	.35	.060
TY-25	.249	.251	1/4	6.35	.450		6	.010	± .001	40	.23	.040
TY-31	.311	.313	5/16	7.92	.512		6	45	.26	.040		
TY-37	.374	.376	3/8	9.53	.575		6	45	.27	.040		
TY-43	.437	.439	7/16	11.1	.638		6	50	.47	.060		
TY-50	.498	.502	1/2	12.7	.750	± .010	6	.015	± .002	50	.72	.060
TY-56	.560	.564	9/16	14.27	.812					6	50	.75
TY-62	.623	.627	5/8	15.88	.875		7	50	.82	.060		
TY-75	.748	.752	3/4	19.05	1.000		8	55	.97	.060		
TY-87	.873	.877	7/8	22.23	1.125		10	60	1.1	.060		
TY-100	.998	1.002	1	25.4	1.250		10	65	1.2	.060		

* FOR PLATED RINGS ADD .002" TO MAXIMUM THICKNESS.

LARGER SIZES MAY BE AVAILABLE UPON REQUEST.

î BASED ON HOUSINGS/SHAFTS MADE OF COLD ROLLED STEEL. FOR AN EXPLANATION OF FORMULAS USED TO DERIVE THRUST LOAD AND OTHER PERFORMANCE DATA, CONTACT THE ROTOR CLIP ENGINEERING DEPT.

THRUST LOAD CAPACITY IF APPLICABLE TO PARTS MADE FROM CARBON SPRING STEEL AND STAINLESS STEEL MATERIALS ONLY.

HARDNESS RANGES: STAINLESS STEEL RINGS (PH 15-7MO)

RING TYPE	SIZE RANGE	SCALE	ROCKWELL HARDNESS
TY	9-21,25-37	15N	82.5-86*
	24,43+	15N	82.5-86

HARDNESS RANGES: BERYLLIUM COPPER RINGS

RING TYPE	SIZE RANGE	SCALE	ROCKWELL HARDNESS
TY	9-21,25-37	15N	77-82*
	24,43+	15N	77-82

HARDNESS RANGES: CARBON STEEL RINGS (SAE 1060-1090)

RING TYPE	SIZE RANGE	SCALE	ROCKWELL HARDNESS
TY	9-21,25-37	15N	84-86*
	24,43+	15N	84-86

*HARDNESS CAN NOT BE CHECKED WITH ANY DEGREE OF ACCURACY DIRECTLY ON THESE RINGS.

Internal, Self-Locking Push-On

The internal version of the TY featuring a series of prongs protruding outward. The ends create interference with the housing when the ring is installed and a load introduced to the other side.

TI Housing Rings

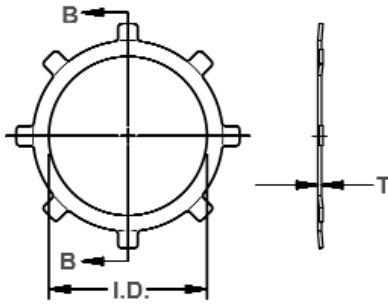

Inside Diameter With Section B-B

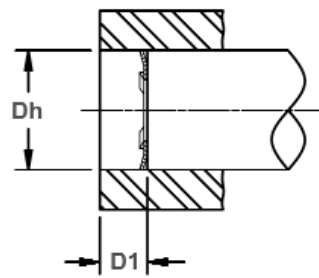

Housing Diameter

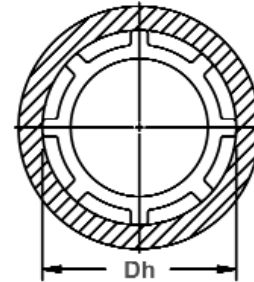

RING NO.	HOUSING DIAMETER				INSIDE DIAMETER		RING SIZE & WEIGHT				Min. Distance Face of part to end of housing				
	Dh DEC		Dh FRACT	Dh mm	I.D.	Tol.	THICKNESS***		No. of Prongs	Thrust Load lbs.		Weight Per 1000 Pcs. lbs.			
	FROM	TO					T	Tol.							
TI-31	.311	.313	5/16	7.92	.136	±.005	.010	±.001	6	81	.11	.040			
TI-37	.374	.376	3/8	9.53	.175				6	76	.16	.040			
TI-43	.437	.439	7/16	11.13	.237				6	71	.20	.040			
TI-44	.440	.442	-	11.20	.258				6	41	.18	.040			
TI-50	.498	.502	1/2	12.7	.258				6	61	.24	.040			
TI-56	.560	.564	9/16	14.27	.312				6	51	.29	.040			
TI-62	.623	.627	5/8	15.85	.390				6	46	.30	.040			
TI-63	.638	.640	-	16.23	.390				6	43	.32	.040			
TI-75	.748	.752	3/4	19.05	.500				±.010	.015	±.002	8	76	.62	.060
TI-87	.873	.877	7/8	22.23	.625							8	71	.75	.060
TI-93	.936	.940	15/16	23.83	.687	10	71	.85				.060			
TI-100	.998	1.002	1	25.4	.750	10	75	.91				.060			
TI-112	1.123	1.127	1 1/8	28.58	.813	10	60	1.30				.060			
TI-125	1.248	1.252	1 1/4	31.75	.938	10	60	1.50				.060			
TI-143	1.436	1.44	1 7/16	36.51	1.117	12	60	1.73				.060			
TI-150	1.498	1.502	1 1/2	38.10	1.188	12	60	1.80				.060			
TI-175	1.748	1.752	1 3/4	44.45	1.438	12	55	2.10				.060			
TI-200	1.998	2.002	2	50.80	1.600	14	55	3.00				.060			

*** FOR PLATED RINGS ADD .002" TO MAXIMUM THICKNESS. LARGER SIZES MAY BE AVAILABLE UPON REQUEST.
 † BASED ON HOUSINGS/SHAFTS MADE OF COLD ROLLED STEEL. FOR AN EXPLANATION OF FORMULAS USED TO DERIVE THRUST LOAD AND OTHER PERFORMANCE DATA, CONTACT THE ROTOR CLIP ENGINEERING DEPT.
 THRUST LOAD CAPACITY IF APPLICABLE TO PARTS MADE FROM CARBON SPRING STEEL AND STAINLESS STEEL MATERIALS ONLY.

PLUNGER

For Fast, Easy Installation Of Rotor Clip TX, TY Rings.

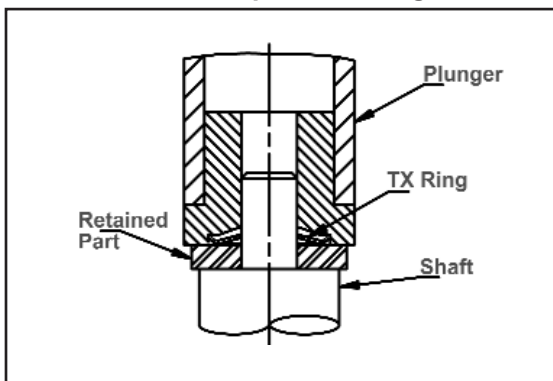

A cylindrical plunger can be easily made to install TX, TY rings. The ring is positioned at the opening of the plunger and then pushed or tapped onto the shaft, as illustrated.

HARDNESS RANGES: STAINLESS STEEL RINGS (PH 15-7MO)

RING TYPE	SIZE RANGE	SCALE	ROCKWELL HARDNESS
TI	31-62	15N	82.5-86*
	75+	15N	82.5-86

HARDNESS RANGES: BERYLLIUM COPPER RINGS

RING TYPE	SIZE RANGE	SCALE	ROCKWELL HARDNESS
TI	31-62	15N	77-82*
	75+	15N	77-82

HARDNESS RANGES: CARBON STEEL RINGS (SAE 1060-1090)

RING TYPE	SIZE RANGE	SCALE	ROCKWELL HARDNESS
TI	31-62	15N	84-86*
	75+	15N	84-86

*HARDNESS CAN NOT BE CHECKED WITH ANY DEGREE OF ACCURACY DIRECTLY ON THESE RINGS.



DHO Housing Rings

(DIN 472)

Axially Assembled, Internal, Metric

Once installed in the groove of a housing/bore, the portion of the ring protruding from the groove (also called a "shoulder") holds an assembly in place.

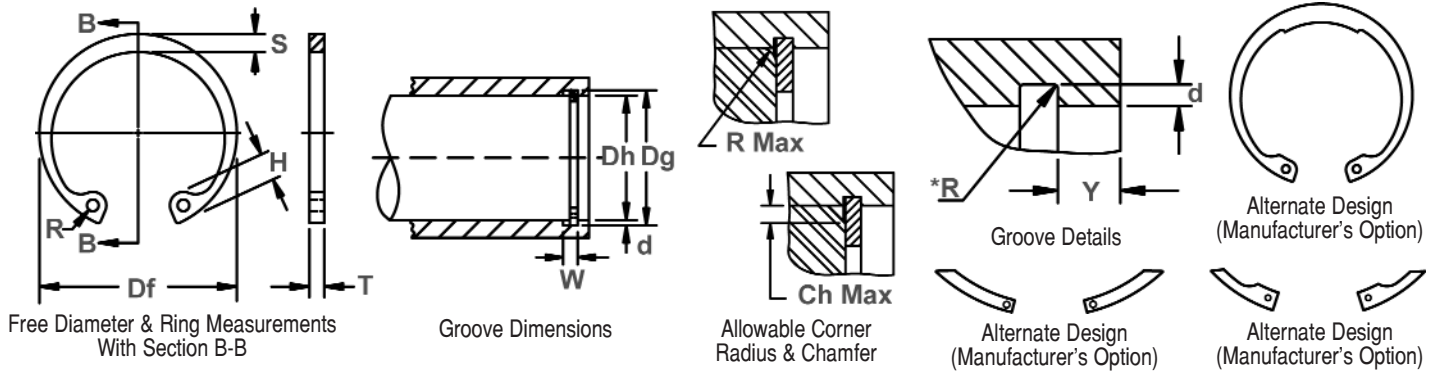

RING NO.	HOUSING Dia. (mm)	GROOVE SIZE				RINGS SIZE & WEIGHT						SUPPLEMENTARY DATA						
		DIAMETER		WIDTH	DEPTH	THICKNESS ***		FREE DIAMETER		LUG HT.	MAX. SEC.	HOLE DIA.	WEIGHT	EDGE MARGIN	THRUST LOAD Ring	THRUST LOAD Groove	Allowable Rad./Cham.	Max. load w/ R/Ch Max.
		Dh	Dg Tol.	W Min.	d	T Tol.	Df Tol.	H Max.	S Ref.	R Min.	Kg/1000	Y Min.	Pr kN	Pg kN	R/Ch Max.	P'r kN		
DHO-8	8	8,4	+0,09	0,90	0,20	0,80	-0,05	8,7		2,4	1,1	1,0	0,10	0,6	2,0	0,86	0,5	1,5
DHO-9	9	9,4		0,90	0,20	0,80		9,8		2,5	1,3	1,0	0,13	0,6	2,0	0,96	0,5	1,5
DHO-10	10	10,4		1,10	0,20	1,00		10,8		3,2	1,4	1,2	0,26	0,6	4,0	1,08	0,5	2,2
DHO-11	11	11,4		1,10	0,20	1,00		11,8	+0,36	3,3	1,5	1,2	0,31	0,6	4,0	1,17	0,5	2,3
DHO-12	12	12,5		1,10	0,25	1,00		13,0	-0,10	3,4	1,7	1,5	0,37	0,8	4,0	1,60	0,5	2,3
DHO-13	13	13,6	+0,11	1,10	0,30	1,00		14,1		3,6	1,8	1,5	0,42	0,9	4,2	2,10	0,5	2,3
DHO-14	14	14,6		1,10	0,30	1,00		15,1		3,7	1,8	1,7	0,52	0,9	4,5	2,25	0,5	2,3
DHO-15	15	15,7		1,10	0,35	1,00		16,2		3,7	2,0	1,7	0,56	1,1	5,0	2,80	0,5	2,3
DHO-16	16	16,8		1,10	0,40	1,00		17,3		3,8	2,0	1,7	0,60	1,2	5,5	3,40	1,0	2,6
DHO-17	17	17,8		1,10	0,40	1,00		18,3		3,9	2,1	1,7	0,65	1,2	6,0	3,60	1,0	2,5
DHO-18	18	19,0		1,10	0,50	1,00		19,5		4,1	2,2	2,0	0,74	1,5	6,5	4,80	1,0	2,6
DHO-19	19	20,0		1,10	0,50	1,00		20,5		4,1	2,2	2,0	0,83	1,5	6,8	5,10	1,0	2,6
DHO-20	20	21,0	+0,13	1,10	0,50	1,00		21,5	+0,42	4,1	2,3	2,0	0,90	1,5	7,2	5,40	1,0	2,6
DHO-21	21	22,0		1,10	0,50	1,00		22,5	-0,13	4,2	2,4	2,0	1,00	1,5	7,6	5,70	1,0	2,6
DHO-22	22	23,0		1,10	0,50	1,00		23,5		4,2	2,5	2,0	1,10	1,5	8,0	5,90	1,0	2,7
DHO-23	23	24,1		1,30	0,55	1,20		24,6		4,2	2,5	2,0	1,34	1,7	8,0	6,80	1,0	4,6
DHO-24	24	25,2		1,30	0,60	1,20	-0,06	25,9		4,4	2,6	2,0	1,42	1,8	13,9	7,70	1,0	4,6
DHO-25	25	26,2		1,30	0,60	1,20		26,9	+0,42	4,5	2,7	2,0	1,50	1,8	14,6	8,00	1,0	4,7
DHO-26	26	27,2	+0,21	1,30	0,60	1,20		27,9	-0,21	4,7	2,8	2,0	1,60	1,8	13,8	8,40	1,0	4,6
DHO-27	27	28,4		1,30	0,70	1,20		29,1		4,7	2,9	2,0	1,75	2,1	13,3	10,10	1,0	4,5
DHO-28	28	29,4		1,30	0,70	1,20		30,1		4,8	2,9	2,0	1,80	2,1	13,3	10,50	1,0	4,5
DHO-29	29	30,4		1,30	0,70	1,20		31,1		4,8	3,0	2,0	1,88	2,1	13,6	10,90	1,0	4,6
DHO-30	30	31,4		1,30	0,70	1,20		32,1		4,8	3,0	2,0	2,06	2,1	13,7	11,30	1,0	4,6
DHO-31	31	32,7		1,30	0,85	1,20		33,4		5,2	3,1	2,5	2,10	2,6	13,8	14,10	1,0	4,7
DHO-32	32	33,7		1,30	0,85	1,20		34,4	+0,50	5,4	3,2	2,5	2,21	2,6	13,8	14,60	1,0	4,7
DHO-33	33	34,7	+0,25	1,30	0,85	1,20		35,5	-0,25	5,4	3,3	2,5	2,40	2,6	14,3	15,00	1,0	4,9
DHO-34	34	35,7		1,60	0,85	1,50		36,5		5,4	3,3	2,5	3,20	2,6	26,2	15,40	1,5	6,3
DHO-35	35	37,0		1,60	1,00	1,50		37,8		5,4	3,4	2,5	3,54	3,0	26,9	18,80	1,5	6,4
DHO-36	36	38,0		1,60	1,00	1,50		38,8		5,4	3,5	2,5	3,70	3,0	26,4	19,40	1,5	6,4
DHO-37	37	39,0		1,60	1,00	1,50		39,8		5,5	3,6	2,5	3,74	3,0	27,1	19,80	1,5	6,5
DHO-38	38	40,0		1,60	1,00	1,50		40,8		5,5	3,7	2,5	3,90	3,0	28,2	22,50	1,5	6,7

ALL DIMENSIONS IN MILLIMETERS.

*The radius "R" on the load side must not exceed 0.1 T.

*** FOR PLATED RINGS, ADD 0.05 TO THE LISTED MAXIMUM THICKNESS. MAXIMUM RING THICKNESS WILL BE A MINIMUM OF 0.005 LESS THAN THE LISTED GROOVE WIDTH (W) MINIMUM.

FOR HARDNESS SPECIFICATIONS, SEE END OF THIS SECTION.

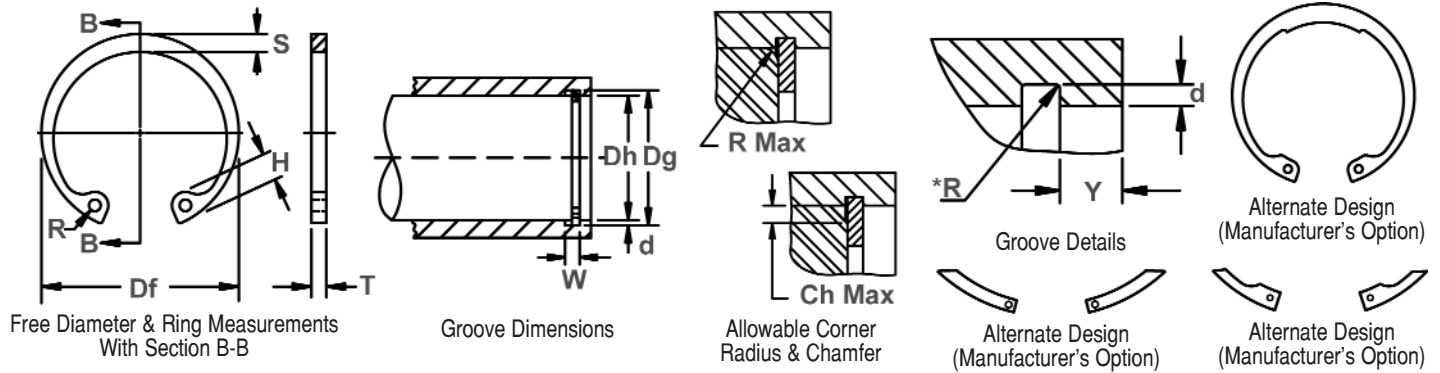

RING NO.	HOUSING Dia. (mm)	GROOVE SIZE					RINGS SIZE & WEIGHT							SUPPLEMENTARY DATA				
		DIAMETER		WIDTH	DEPTH	THICKNESS ***		FREE DIAMETER		LUG HT.	MAX. SEC.	HOLE DIA.	WEIGHT	EDGE MARGIN	THRUST LOAD Ring	THRUST LOAD Groove	Allowable Rad./ Cham.	Max. load w/ R/Ch Max.
		Dh	Dg Tol.	W Min.	d	T Tol.	Df Tol.	H Max.	S Ref.	R Min.	kg/ 1000	Y Min.	Pr kN	Pg kN	R/Ch Max.	P'r kN		
DHO-39	39	41.0	+0.25	1.60	1.00	1.50	-0.06	42.0	+0.90	5.6	3.8	2.5	4.00	3.0	28.8	26.00	1.5	6.9
DHO-40	40	42.5		1.85	1.25	1.75		43.5		5.8	3.9	2.5	4.70	3.8	44.6	27.00	2.0	8.3
DHO-41	41	43.5		1.85	1.25	1.75		44.5		5.9	4.0	2.5	5.10	3.8	45.0	27.60	2.0	8.3
DHO-42	42	44.5		1.85	1.25	1.75		45.5		5.9	4.1	2.5	5.40	3.8	44.7	28.40	2.0	8.4
DHO-43	43	45.5		1.85	1.25	1.75		46.5		5.9	4.2	2.5	5.60	3.8	44.5	28.80	2.0	8.4
DHO-44	44	46.5		1.85	1.25	1.75		47.5		6.0	4.2	2.5	5.80	3.8	43.3	29.50	2.0	8.3
DHO-45	45	47.5		1.85	1.25	1.75		48.5		6.2	4.3	2.5	6.00	3.8	43.1	30.20	2.0	8.2
DHO-46	46	48.5		1.85	1.25	1.75		49.5		6.3	4.4	2.5	6.05	3.8	42.9	30.80	2.0	8.2
DHO-47	47	49.5		1.85	1.25	1.75		50.5		6.4	4.4	2.5	6.10	3.8	43.5	31.40	2.0	8.3
DHO-48	48	50.5		1.85	1.25	1.75		51.5		6.4	4.5	2.5	6.70	3.8	43.2	32.00	2.0	8.4
DHO-50	50	53.0	+0.30	2.15	1.50	2.00	-0.46	54.2	+1.10	6.5	4.6	2.5	7.30	4.5	60.8	40.50	2.0	12.1
DHO-51	51	54.0		2.15	1.50	2.00		55.2		6.5	4.7	2.5	7.75	4.5	60.2	41.20	2.0	12.0
DHO-52	52	55.0		2.15	1.50	2.00		56.2		6.7	4.7	2.5	8.20	4.5	60.2	42.00	2.0	12.0
DHO-53	53	56.0		2.15	1.50	2.00		57.2		6.7	4.9	2.5	8.22	4.5	60.7	42.90	2.0	12.1
DHO-54	54	57.0		2.15	1.50	2.00		58.2		6.7	5.0	2.5	8.25	4.5	60.4	43.60	2.0	12.3
DHO-55	55	58.0		2.15	1.50	2.00		59.2		6.8	5.0	2.5	8.30	4.5	60.3	44.40	2.0	12.5
DHO-56	56	59.0		2.15	1.50	2.00		60.2		6.8	5.1	2.5	8.80	4.5	60.3	45.20	2.0	12.6
DHO-57	57	60.0		2.15	1.50	2.00		61.2		6.8	5.1	2.5	9.40	4.5	60.8	46.00	2.0	12.7
DHO-58	58	61.0		2.15	1.50	2.00		62.2		6.9	5.2	2.5	10.50	4.5	60.8	46.70	2.0	12.7
DHO-60	60	63.0		+0.30	2.15	1.50		2.00		-0.07	64.2	+1.10	7.3	5.4	2.5	11.10	4.5	61.0
DHO-62	62	65.0	2.15		1.50	2.00	66.2	7.3	5.5		2.5		11.20	4.5	60.9	49.80	2.0	13.0
DHO-63	63	66.0	2.15		1.50	2.00	67.2	7.3	5.6		2.5		12.40	4.5	60.8	50.60	2.0	13.0
DHO-64	64	67.0	2.15		1.50	2.00	68.2	7.4	5.7		2.5		12.45	4.5	60.6	51.40	2.0	13.0
DHO-65	65	68.0	2.65		1.50	2.50	69.2	7.6	5.8		3.0		14.30	4.5	121	51.80	2.5	20.8
DHO-67	67	70.0	2.65		1.50	2.50	71.5	7.7	6.0		3.0		15.30	4.5	121	53.80	2.5	21.1
DHO-68	68	71.0	2.65		1.50	2.50	72.5	7.8	6.1		3.0		16.00	4.5	119	56.20	2.5	21.0
DHO-70	70	73.0	2.65		1.50	2.50	74.5	7.8	6.2		3.0		16.50	4.5	119	56.20	2.5	21.0
DHO-72	72	75.0	2.65		1.50	2.50	76.5	7.8	6.4		3.0		18.10	4.5	119	58.00	2.5	21.0
DHO-75	75	78.0	2.65		1.50	2.50	79.5	7.8	6.6		3.0		18.80	4.5	118	60.00	2.5	21.0
DHO-76	76	79.0	2.65	1.50	2.50	80.5	7.8	6.6	3.0	19.00	4.5	119	61.00	2.5	21.0			
DHO-78	77	80.0	+0.35	2.65	1.50	2.50	-0.54	82.5	+1.30	8.5	6.8	3.0	20.40	4.5	121	61.60	2.5	21.5
DHO-78	78	81.0		2.65	1.50	2.50		82.5		8.5	6.8	3.0	20.40	4.5	122	62.30	2.5	21.8
DHO-80	80	83.5		2.65	1.75	2.50		85.5		8.5	7.0	3.0	22.00	5.3	120	74.60	2.5	21.8

ALL DIMENSIONS IN MILLIMETERS.

*The radius "R" on the load side must not exceed 0.1 T.

*** FOR PLATED RINGS, ADD 0.05 TO THE LISTED MAXIMUM THICKNESS. MAXIMUM RING THICKNESS WILL BE A MINIMUM OF 0.005 LESS THAN THE LISTED GROOVE WIDTH (W) MINIMUM.

FOR HARDNESS SPECIFICATIONS, SEE END OF THIS SECTION.



DHO Housing Rings

(DIN 472)

Axially Assembled, Internal, Metric

Once installed in the groove of a housing/bore, the portion of the ring protruding from the groove (also called a "shoulder") holds an assembly in place.

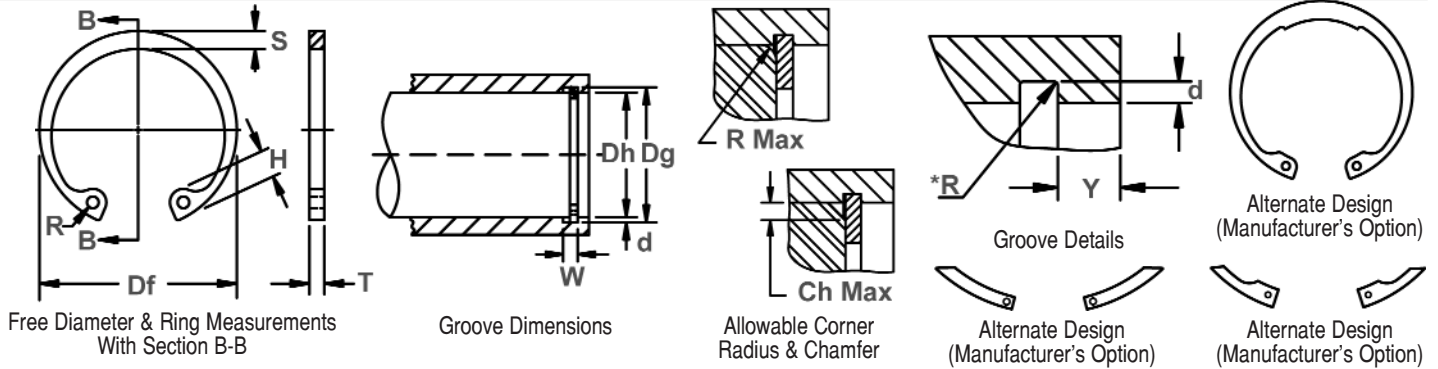

RING NO.	HOUSING Dia. (mm)	GROOVE SIZE			RINGS SIZE & WEIGHT						SUPPLEMENTARY DATA							
		DIAMETER		WIDTH	DEPTH	THICKNESS ***		FREE DIAMETER	LUG HT.	MAX. SEC.	HOLE DIA.	WEIGHT	EDGE MARGIN	THRUST LOAD Ring	THRUST LOAD Groove	Allowable Rad./Cham.	Max. load w/ R/Ch Max.	
		Dh	Dg	Tol.	W Min.	d	T	Tol.	Df	Tol.	H Max.	S Ref.	R Min.	kg/1000	Y Min.	Pr kN	Pg kN	R/Ch Max.
DHO-81	81	84,5		2,65	1,75	2,50		86,5		8,5	7,0	3,0	23,00	5,3	119	75,80	2,5	21,6
DHO-82	82	85,5		2,65	1,75	2,50	-0,07	87,5		8,5	7,0	3,0	24,00	5,3	119	76,6	2,5	21,4
DHO-83	83	86,5		2,65	1,75	2,50		88,5		8,5	7,0	3,0	25,00	5,3	118	77,5	2,5	21,2
DHO-85	85	88,5		3,15	1,75	3,00		90,5		8,6	7,2	3,5	25,30	5,3	201	79,5	3,0	31,2
DHO-88	87	90,5	+0,35	3,15	1,75	3,00		93,5		8,6	7,4	3,5	31,00	5,3	204	81,3	3,0	31,8
DHO-88	88	91,5		3,15	1,75	3,00		93,5	+1,30	8,6	7,4	3,5	31,00	5,3	209	82,0	3,0	32,7
DHO-90	90	93,5		3,15	1,75	3,00	-0,08	95,5	-0,54	8,6	7,6	3,5	33,00	5,3	199	84,0	3,0	31,4
DHO-92	92	95,5		3,15	1,75	3,00		97,5		8,7	7,8	3,5	35,00	5,3	201	85,0	3,0	32,0
DHO-95	95	98,5		3,15	1,75	3,00		100,5		8,8	8,1	3,5	37,00	5,3	195	88,0	3,0	31,4
DHO-98	97	100,5		3,15	1,75	3,00		103,5		9,0	8,3	3,5	41,00	5,3	193	90,0	3,0	31,2
DHO-98	98	101,5		3,15	1,75	3,00		103,5		9,0	8,3	3,5	41,00	5,3	191	91,0	3,0	31,0
DHO-100	100	103,5		3,15	1,75	3,00		105,5		9,2	8,4	3,5	42,00	5,3	188	93,0	3,0	30,8
DHO-102	102	106,0		4,15	2,00	4,00		108,0		9,5	8,5	3,5	55,00	6,0	439	108,0	3,0	72,6
DHO-105	105	109,0		4,15	2,00	4,00		112,0		9,5	8,7	3,5	56,00	6,0	436	112,0	3,0	73,0
DHO-108	107	111,0		4,15	2,00	4,00		115,0		9,5	8,9	3,5	60,00	6,0	425	114,0	3,0	71,6
DHO-108	108	112,0	+0,54	4,15	2,00	4,00		115,0		9,5	8,9	3,5	60,00	6,0	419	115,0	3,0	71,0
DHO-110	110	114,0		4,15	2,00	4,00		117,0		10,4	9,0	3,5	64,50	6,0	415	117,0	3,0	71,0
DHO-112	112	116,0		4,15	2,00	4,00		119,0		10,5	9,1	3,5	72,00	6,0	418	119,0	3,0	72,0
DHO-115	115	119,0		4,15	2,00	4,00		122,0		10,5	9,3	3,5	74,50	6,0	409	122,0	3,0	71,2
DHO-118	117	121,0		4,15	2,00	4,00		125,0		10,7	9,6	3,5	75,50	6,0	399	124,0	3,0	70,0
DHO-118	118	122,0		4,15	2,00	4,00		125,0		10,7	9,6	3,5	75,50	6,0	394	125,0	3,0	69,3
DHO-120	120	124,0		4,15	2,00	4,00	-0,10	127,0		11,0	9,7	3,5	77,00	6,0	396	127,0	3,0	70,0
DHO-122	122	126,0		4,15	2,00	4,00		129,0		11,0	9,8	4,0	78,00	6,0	399	129,0	3,0	71,0
DHO-125	125	129,0		4,15	2,00	4,00		132,0		11,0	10,0	4,0	79,00	6,0	385	132,0	3,0	70,0
DHO-128	127	131,0	+0,63	4,15	2,00	4,00		135,0	+1,50	11,0	10,0	4,0	81,00	6,0	383	135,0	3,0	70,0
DHO-128	128	132,0		4,15	2,00	4,00		135,0	-0,63	11,0	10,2	4,0	81,00	6,0	378	136,0	3,0	69,0
DHO-130	130	134,0		4,15	2,00	4,00		137,0		11,0	10,2	4,0	82,00	6,0	374	138,0	3,0	69,0
DHO-132	132	136,0		4,15	2,00	4,00		139,0		11,0	10,3	4,0	83,00	6,0	366	140,0	3,0	68,0
DHO-135	135	139,0		4,15	2,00	4,00		142,0		11,2	10,5	4,0	84,00	6,0	358	143,0	3,0	67,0
DHO-138	137	141,0		4,15	2,00	4,00		145,0		11,2	10,6	4,0	86,00	6,0	356	145,0	3,0	67,0
DHO-138	138	142,0		4,15	2,00	4,00		145,0		11,2	10,6	4,0	86,00	6,0	352	146,0	3,0	66,5
DHO-140	140	144,0		4,15	2,00	4,00		147,0		11,2	10,7	4,0	87,50	6,0	350	148,0	3,0	66,5

ALL DIMENSIONS IN MILLIMETERS.

*The radius "R" on the load side must not exceed 0.1 T.

*** FOR PLATED RINGS, ADD 0.05 TO THE LISTED MAXIMUM THICKNESS. MAXIMUM RING THICKNESS WILL BE A MINIMUM OF 0.005 LESS THAN THE LISTED GROOVE WIDTH (W) MINIMUM.

FOR HARDNESS SPECIFICATIONS, SEE END OF THIS SECTION.

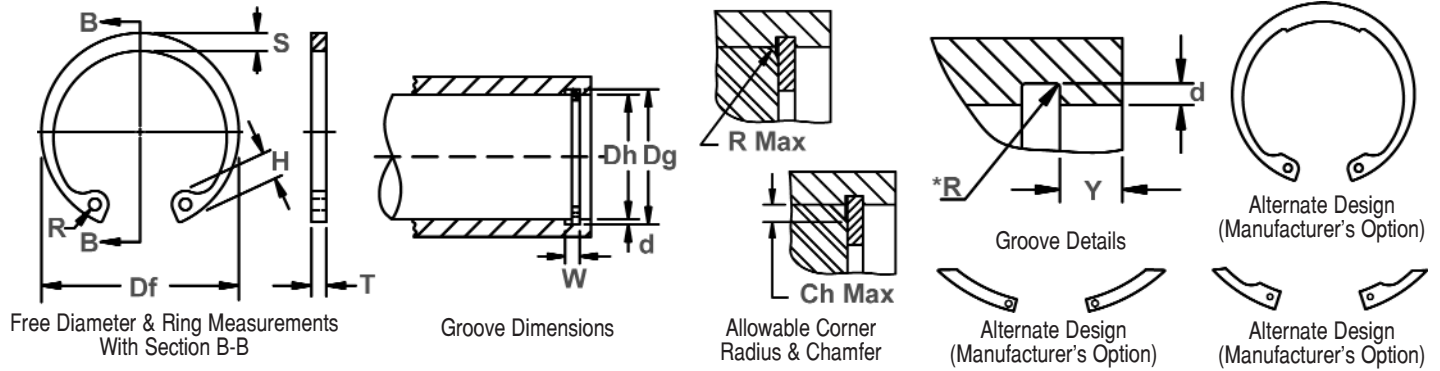

RING NO.	HOUSING Dia. (mm)	GROOVE SIZE			RINGS SIZE & WEIGHT						SUPPLEMENTARY DATA							
		DIAMETER		WIDTH	DEPTH	THICKNESS ***		FREE DIAMETER		LUG HT.	MAX. SEC.	HOLE DIA.	WEIGHT	EDGE MARGIN	THRUST LOAD Ring	THRUST LOAD Groove	Allowable Rad./Cham.	Max. load w/ R/Ch Max.
		Dh	Dg Tol.	W Min.	d	T Tol.	Df Tol.	H Max.	S Ref.	R Min.	kg/1000	Y Min.	Pr kN	Pg kN	R/Ch Max.	P'r kN		
DHO-142	142	146.0		4,15	2,00	4,00		149,0		11,3	10,8	4,0	89,00	6,0	342	150,0	3,0	65,5
DHO-145	145	149,0		4,15	2,00	4,00		152,0		11,4	10,9	4,0	93,00	6,0	336	153,0	3,0	65,0
DHO-148	148	152,0		4,15	2,00	4,00		155,0		11,8	11,1	4,0	100,0	6,0	336	156,0	3,0	65,0
DHO-148	148	152,0		4,15	2,00	4,00		155,0		11,8	11,1	4,0	100,0	6,0	331	157,0	3,0	64,5
DHO-150	150	155,0		4,15	2,50	4,00		158,0		12,0	11,2	4,0	105,0	7,5	326	191,0	3,0	64,0
DHO-152	152	157,0		4,15	2,50	4,00		161,0	+1,50	12,0	11,3	4,0	106,0	7,5	326	202,0	3,5	55,0
DHO-155	155	160,0		4,15	2,50	4,00		164,0	-0,63	12,0	11,4	4,0	107,0	7,5	324	206,0	3,5	55,0
DHO-158	157	162,0	+0,63	4,15	2,50	4,00		167,0		12,3	11,5	4,0	109,0	7,5	328	208,0	3,5	55,5
DHO-158	158	163,0		4,15	2,50	4,00		167,0		12,3	11,5	4,0	109,0	7,5	326	210,0	3,5	55,0
DHO-160	160	165,0		4,15	2,50	4,00		169,0		13,0	11,6	4,0	110,0	7,5	321	212,0	3,5	54,5
DHO-162	162	167,0		4,15	2,50	4,00		171,5		13,0	11,7	4,0	118,0	7,5	321	215,0	3,5	54,5
DHO-165	165	170,0		4,15	2,50	4,00		174,5		13,0	11,8	4,0	125,0	7,5	319	219,0	3,5	54,0
DHO-168	167	172,0		4,15	2,50	4,00		177,5		13,5	12,1	4,0	135,0	7,5	355	221,0	3,5	60,0
DHO-168	168	173,0		4,15	2,50	4,00	-0,10	177,5		13,5	12,1	4,0	135,0	7,5	353	223,0	3,5	60,0
DHO-170	170	175,0		4,15	2,50	4,00		179,5		13,5	12,2	4,0	140,0	7,5	349	225,0	3,5	59,0
DHO-172	172	177,0		4,15	2,50	4,00		181,5		13,5	12,5	4,0	145,0	7,5	357	228,0	3,5	60,0
DHO-175	175	180,0		4,15	2,50	4,00		184,5		13,5	12,7	4,0	150,0	7,5	351	232,0	3,5	59,0
DHO-178	177	182,0		4,15	2,50	4,00		187,5		14,2	12,9	4,0	162,0	7,5	346	235,0	3,5	58,5
DHO-178	178	183,0		4,15	2,50	4,00		187,5		14,2	12,9	4,0	162,0	7,5	344	236,0	3,5	58,0
DHO-180	180	185,0		4,15	2,50	4,00		189,5		14,2	13,2	4,0	165,0	7,5	347	238,0	3,5	58,5
DHO-182	182	187,0		4,15	2,50	4,00		191,5		14,2	13,5	4,0	168,0	7,5	355	241,0	3,5	60,0
DHO-185	185	190,0		4,15	2,50	4,00		194,5		14,2	13,7	4,0	170,0	7,5	349	245,0	3,5	59,0
DHO-188	187	192,0		4,15	2,50	4,00		197,5	+1,70	14,2	13,8	4,0	174,0	7,5	345	248,0	3,5	58,5
DHO-188	188	193,0		4,15	2,50	4,00		197,5	-0,72	14,2	13,8	4,0	174,0	7,5	343	249,0	3,5	58,0
DHO-190	190	195,0	+0,72	4,15	2,50	4,00		199,5		14,2	13,8	4,0	175,0	7,5	340	251,0	3,5	57,5
DHO-192	192	197,0		4,15	2,50	4,00		201,5		14,2	13,8	4,0	178,0	7,5	336	254,0	3,5	57,0
DHO-195	195	200,0		4,15	2,50	4,00		204,5		14,2	13,8	4,0	183,0	7,5	330	258,0	3,5	55,5
DHO-198	197	202,0		4,15	2,50	4,00		207,5		14,2	14,0	4,0	190,0	7,5	330	260,0	3,5	55,5
DHO-198	198	203,0		4,15	2,50	4,00		207,5		14,2	14,0	4,0	190,0	7,5	329	262,0	3,5	55,5
DHO-200	200	205,0		4,15	2,50	4,00		209,5		14,2	14,0	4,0	195,0	7,5	325	265,0	3,5	55,0
DHO-202	202	208,0		5,15	3,00	5,00		214,0		14,2	14,0	4,0	210,0	9,0	625	321,0	4,0	92,5
DHO-205	205	211,0		5,15	3,00	5,00	-0,12	217,0		14,2	14,0	4,0	225,0	9,0	616	326,0	4,0	91,5
DHO-205	207	213,0		5,15	3,00	5,00		217,0		14,2	14,0	4,0	225,0	9,0	610	329,0	4,0	90,0

ALL DIMENSIONS IN MILLIMETERS.

*The radius "R" on the load side must not exceed 0.1 T.

*** FOR PLATED RINGS, ADD 0.05 TO THE LISTED MAXIMUM THICKNESS. MAXIMUM RING THICKNESS WILL BE A MINIMUM OF 0.005

LESS THAN THE LISTED GROOVE WIDTH (W) MINIMUM.

FOR HARDNESS SPECIFICATIONS, SEE END OF THIS SECTION.



DHO Housing Rings

(DIN 472)

Axially Assembled, Internal, Metric

Once installed in the groove of a housing/bore, the portion of the ring protruding from the groove (also called a "shoulder") holds an assembly in place.

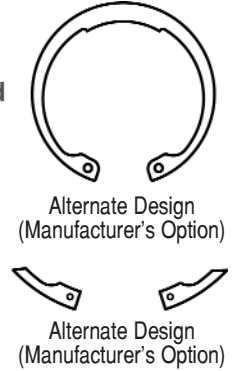
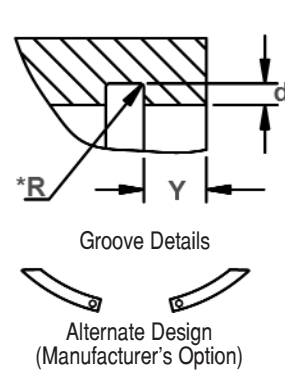
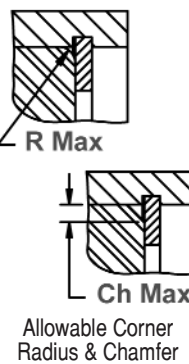
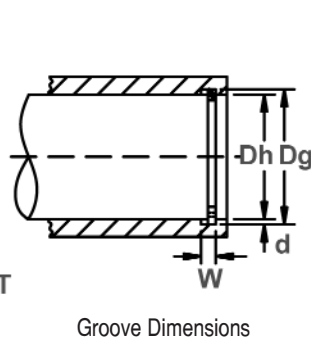
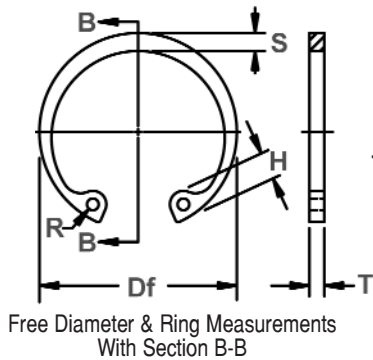

RING NO.	HOUSING Dia. (mm)	GROOVE SIZE					RINGS SIZE & WEIGHT							SUPPLEMENTARY DATA				
		DIAMETER		WIDTH	DEPTH	THICKNESS ***	FREE DIAMETER		LUG HT.	MAX. SEC.	HOLE DIA.	WEIGHT	EDGE MARGIN	THRUST LOAD Ring	THRUST LOAD Groove	Allowable Rad./ Cham.	Max. load w/ R/Ch Max.	
		Dh	Dg Tol.	W Min.	d	T Tol.	Df Tol.	Tol.	H Max.	S Ref.	R Min.	kg/1000	Y Min.	Pr kN	Pg kN	R/Ch Max.	P'r kN	
DHO-210	208	214,0		5,15	3,00	5,00		222,0		14,2	14,0	4,0	270,0	9,0	607	331,0	4,0	90,0
DHO-210	210	216,0		5,15	3,00	5,00		222,0		14,2	14,0	4,0	270,0	9,0	601	333,0	4,0	89,5
DHO-210	212	218,0		5,15	3,00	5,00		222,0		14,2	14,0	4,0	270,0	9,0	596	337,0	4,0	88,5
DHO-215	215	221,0		5,15	3,00	5,00		227,0		14,2	14,0	4,0	300,0	9,0	586	341,0	4,0	87,0
DHO-215	217	223,0		5,15	3,00	5,00		227,0		14,2	14,0	4,0	300,0	9,0	581	345,0	4,0	86,0
DHO-220	218	224,0		5,15	3,00	5,00		232,0	+1,70	14,2	14,0	4,0	315,0	9,0	580	346,0	4,0	86,0
DHO-220	220	226,0		5,15	3,00	5,00		232,0	-0,72	14,2	14,0	4,0	315,0	9,0	574	349,0	4,0	85,0
DHO-220	222	228,0		5,15	3,00	5,00		232,0		14,2	14,0	4,0	315,0	9,0	568	353,0	4,0	84,0
DHO-225	225	231,0	+0,72	5,15	3,00	5,00		237,0		14,2	14,0	4,0	323,0	9,0	560	357,0	4,0	83,0
DHO-225	227	233,0		5,15	3,00	5,00		237,0		14,2	14,0	4,0	323,0	9,0	555	361,0	4,0	82,0
DHO-230	228	234,0		5,15	3,00	5,00		242,0		14,2	14,0	4,0	330,0	9,0	554	362,0	4,0	82,0
DHO-230	230	236,0		5,15	3,00	5,00		242,0		14,2	14,0	4,0	330,0	9,0	549	365,0	4,0	81,0
DHO-230	232	238,0		5,15	3,00	5,00	-0,12	242,0		14,2	14,0	4,0	330,0	9,0	544	369,0	4,0	80,50
DHO-235	235	241,0		5,15	3,00	5,00		247,0		14,2	14,0	4,0	338,0	9,0	536	373,0	4,0	79,50
DHO-235	237	243,0		5,15	3,00	5,00		247,0		14,2	14,0	4,0	338,0	9,0	531	376,0	4,0	79,00
DHO-240	238	244,0		5,15	3,00	5,00		252,0		14,2	14,0	4,0	345,0	9,0	530	378,0	4,0	79,00
DHO-240	240	246,0		5,15	3,00	5,00		252,0		14,2	14,0	4,0	345,0	9,0	525	380,0	4,0	77,50
DHO-240	242	248,0		5,15	3,00	5,00		252,0	+2,00	14,2	14,0	4,0	345,0	9,0	521	385,0	4,0	77,00
DHO-245	245	251,0		5,15	3,00	5,00		257,0	-0,81	14,2	14,0	4,0	353,0	9,0	514	389,0	4,0	76,50
DHO-245	247	253,0		5,15	3,00	5,00		257,0		14,2	14,0	4,0	353,0	9,0	509	392,0	4,0	76,00
DHO-250	248	254,0	+0,81	5,15	3,00	5,00		262,0		14,2	14,0	4,0	360,0	9,0	507	394,0	4,0	75,50
DHO-250	250	256,0		5,15	3,00	5,00		262,0		14,2	14,0	4,0	360,0	9,0	504	396,0	4,0	75,00
DHO-252	252	260,0		5,15	4,00	5,00		262,0		14,2	16,0	5,0	360,0	12,0	557	535,0	4,0	83,00
DHO-255	255	263,0		5,15	4,00	5,00		270,0		16,2	16,0	5,0	368,0	12,0	549	541,0	4,0	81,50
DHO-255	257	265,0		5,15	4,00	5,00		270,0		16,2	16,0	5,0	368,0	12,0	545	546,0	4,0	81,00

ALL DIMENSIONS IN MILLIMETERS.

*The radius "R" on the load side must not exceed 0.1 T.

*** FOR PLATED RINGS, ADD 0.05 TO THE LISTED MAXIMUM THICKNESS.

MAXIMUM RING THICKNESS WILL BE A MINIMUM OF 0.005 LESS THAN THE LISTED GROOVE WIDTH (W) MINIMUM.

FOR HARDNESS SPECIFICATIONS, SEE END OF THIS SECTION.

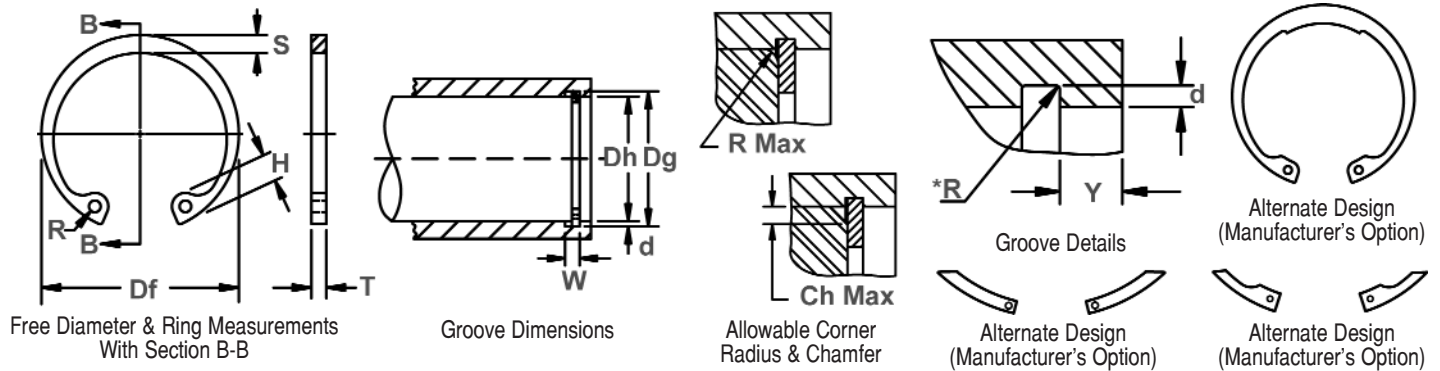

RING NO.	HOUSING Dia. (mm)	GROOVE SIZE					RINGS SIZE & WEIGHT							SUPPLEMENTARY DATA				
		DIAMETER		WIDTH	DEPTH	THICKNESS ***	FREE DIAMETER		LUG HT.	MAX. SEC.	HOLE DIA.	WEIGHT	EDGE MARGIN	THRUST LOAD Ring	THRUST LOAD Groove	Allowable Rad./Cham.	Max. load w/ R/Ch Max.	
		Dh	Dg	Tol.	W Min.	d	T	Tol.	Df	Tol.	H Max.	S Ref.	R Min.	kg/1000	Y Min.	Pr kN	Pg kN	R/Ch Max.
DHO-260	258	266.0		5,15	4,00	5,00		275,0		16,2	16,0	5,0	375,0	12,0	543	548,0	4,0	80,50
DHO-260	260	268,0		5,15	4,00	5,00		275,0		16,2	16,0	5,0	375,0	12,0	538	553,0	4,0	80,00
DHO-260	262	270,0		5,15	4,00	5,00		275,0		16,2	16,0	5,0	375,0	12,0	535	556,0	4,0	79,00
DHO-265	265	273,0		5,15	4,00	5,00		280,0		16,2	16,0	5,0	383,0	12,0	528	563,0	4,0	78,50
DHO-265	267	275,0		5,15	4,00	5,00		280,0		16,2	16,0	5,0	383,0	12,0	524	566,0	4,0	78,00
DHO-270	268	276,0		5,15	4,00	5,00		285,0		16,2	16,0	5,0	388,0	12,0	522	570,0	4,0	77,50
DHO-270	270	278,0		5,15	4,00	5,00		285,0		16,2	16,0	5,0	388,0	12,0	518	573,0	4,0	77,00
DHO-270	272	280,0		5,15	4,00	5,00		285,0		16,2	16,0	5,0	388,0	12,0	515	577,0	4,0	76,50
DHO-275	275	283,0		5,15	4,00	5,00		290,0	+2,00	16,2	16,0	5,0	393,0	12,0	509	585,0	4,0	75,50
DHO-275	277	285,0	+0,81	5,15	4,00	5,00	-0,12	290,0	-0,81	16,2	16,0	5,0	393,0	12,0	505	587,0	4,0	75,00
DHO-280	278	286,0		5,15	4,00	5,00		295,0		16,2	16,0	5,0	400,0	12,0	504	590,0	4,0	75,00
DHO-280	280	288,0		5,15	4,00	5,00		295,0		16,2	16,0	5,0	400,0	12,0	499	593,0	4,0	74,00
DHO-280	282	290,0		5,15	4,00	5,00		295,0		16,2	16,0	5,0	400,0	12,0	497	599,0	4,0	74,00
DHO-285	285	293,0		5,15	4,00	5,00		300,0		16,2	16,0	5,0	408,0	12,0	491	605,0	4,0	73,00
DHO-285	287	295,0		5,15	4,00	5,00		300,0		16,2	16,0	5,0	408,0	12,0	487	610,0	4,0	72,00
DHO-290	288	296,0		5,15	4,00	5,00		305,0		16,2	16,0	5,0	415,0	12,0	485	611,0	4,0	72,00
DHO-290	290	298,0		5,15	4,00	5,00		305,0		16,2	16,0	5,0	415,0	12,0	482	615,0	4,0	71,50
DHO-290	292	300,0		5,15	4,00	5,00		305,0		16,2	16,0	5,0	415,0	12,0	479	620,0	4,0	71,00
DHO-295	295	303,0		5,15	4,00	5,00		310,0		16,2	16,0	5,0	426,0	12,0	474	625,0	4,0	70,50
DHO-295	297	305,0		5,15	4,00	5,00		310,0		16,2	16,0	5,0	426,0	12,0	471	630,0	4,0	70,50
DHO-300	298	306,0		5,15	4,00	5,00		315,0		16,2	16,0	5,0	435,0	12,0	469	631,0	4,0	69,50
DHO-300	300	308,0		5,15	4,00	5,00		315,0		16,2	16,0	5,0	435,0	12,0	466	636,0	4,0	69,00
DHO-305	305	315,0		6,20	5,00	6,00	-0,15	322,0	+2,00	16,2	20,0	6,0	755,0	15,0	961	810,0	5,0	114,00
DHO-310	310	320,0	+0,89	6,20	5,00	6,00		327,0	-0,90	20,2	20,0	6,0	770,0	15,0	947	823,0	5,0	113,00

ALL DIMENSIONS IN MILLIMETERS.

*The radius "R" on the load side must not exceed 0.1 T.

*** FOR PLATED RINGS, ADD 0.05 TO THE LISTED MAXIMUM THICKNESS.

MAXIMUM RING THICKNESS WILL BE A MINIMUM OF 0.005 LESS THAN THE LISTED GROOVE WIDTH (W) MINIMUM.

FOR HARDNESS SPECIFICATIONS, SEE END OF THIS SECTION.



DHO Housing Rings

(DIN 472)

Axially Assembled, Internal, Metric

Once installed in the groove of a housing/bore, the portion of the ring protruding from the groove (also called a "shoulder") holds an assembly in place.

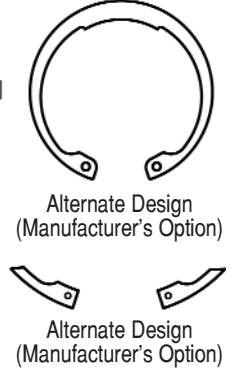
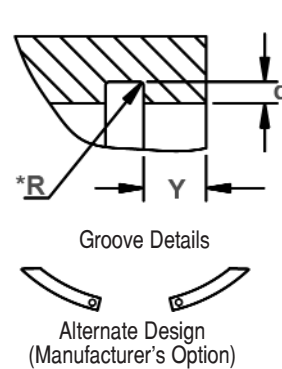
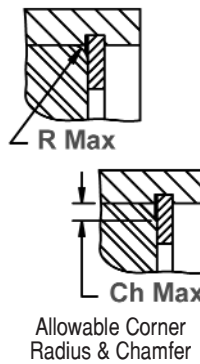
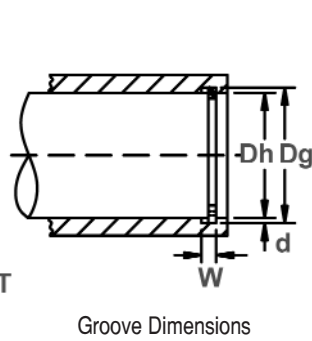
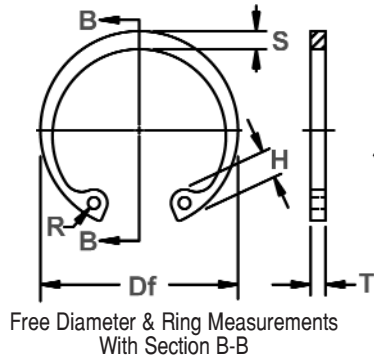

RING NO.	HOUSING Dia. (mm)		GROOVE SIZE			RINGS SIZE & WEIGHT					SUPPLEMENTARY DATA							
			DIAMETER		WIDTH	DEPTH	THICKNESS ***		FREE DIAMETER	LUG HT.	MAX. SEC.	HOLE DIA.	WEIGHT	EDGE MARGIN	THRUST LOAD Ring	THRUST LOAD Groove	Allowable Rad./Cham.	Max. load w/ R/Ch Max.
			Dh	Dg	Tol.	W Min.	d	T	Tol.	Df	Tol.	H Max.	S Ref.	R Min.	kg/1000	Y Min.	Pr kN	Pg kN
DHO-315	315	325.0	+0.89	6.20	5.00	6.00	-0.15	332.0	+2.00	20.2	20.0	6.0	785.0	15.0	934	837.0	5.0	111.00
DHO-320	320	330.0		6.20	5.00	6.00		337.0		20.2	20.0	6.0	800.0	15.0	919	850.0	5.0	109.00
DHO-325	325	335.0		6.20	5.00	6.00		342.0		20.2	20.0	6.0	810.0	15.0	906	864.0	5.0	108.00
DHO-330	330	340.0		6.20	5.00	6.00		347.0		20.2	20.0	6.0	820.0	15.0	894	876.0	5.0	106.00
DHO-335	335	345.0		6.20	5.00	6.00		352.0		20.2	20.0	6.0	830.0	15.0	880	890.0	5.0	105.00
DHO-340	340	350.0		6.20	5.00	6.00		357.0		20.2	20.0	6.0	840.0	15.0	869	903.0	5.0	104.00
DHO-345	345	355.0		6.20	5.00	6.00		362.0		20.2	20.0	6.0	855.0	15.0	857	916.0	5.0	102.00
DHO-350	350	360.0		6.20	5.00	6.00		367.0		20.2	20.0	6.0	870.0	15.0	846	929.0	5.0	101.00
DHO-355	355	365.0		6.20	5.00	6.00		372.0		20.2	20.0	6.0	880.0	15.0	834	942.0	5.0	99.00
DHO-360	360	370.0		6.20	5.00	6.00		377.0		20.2	20.0	6.0	890.0	15.0	823	955.0	5.0	98.00
DHO-365	365	375.0		6.20	5.00	6.00		382.0		20.2	20.0	6.0	906.0	15.0	813	968.0	5.0	97.00
DHO-370	370	380.0		6.20	5.00	6.00		387.0		20.2	20.0	6.0	920.0	15.0	803	981.0	5.0	95.00
DHO-375	375	385.0		6.20	5.00	6.00		392.0		20.2	20.0	6.0	932.0	15.0	793	994.0	5.0	94.00
DHO-380	380	390.0		6.20	5.00	6.00		397.0		20.2	20.0	6.0	940.0	15.0	784	1008.0	5.0	93.00
DHO-385	385	395.0		6.20	5.00	6.00		402.0		20.2	20.0	6.0	950.0	15.0	774	1021.0	5.0	92.00
DHO-390	390	400.0		6.20	5.00	6.00		407.0		20.2	20.0	6.0	960.0	15.0	764	1033.0	5.0	91.00
DHO-395	395	405.0		6.20	5.00	6.00		412.0		20.2	20.0	6.0	972.0	15.0	756	1047.0	5.0	90.00
DHO-400	400	410.0		+1.00	6.20	5.00		6.00		-1.00	417.0	+2.00	20.2	20.0	6.0	980.0	15.0	746
DHO-410	410	422.0	7.20		6.00	7.00	430.0	26.2	26.0		6.0		1380.0	18.0	1512	1307.0	6.0	150.00
DHO-420	420	432.0	7.20		6.00	7.00	440.0	26.2	26.0		6.0		1410.0	18.0	1480	1338.0	6.0	147.00
DHO-430	430	442.0	7.20		6.00	7.00	450.0	26.2	26.0		6.0		1440.0	18.0	1446	1369.0	6.0	144.00
DHO-440	440	452.0	7.20		6.00	7.00	460.0	26.2	26.0		6.0		1470.0	18.0	1418	1401.0	6.0	141.00
DHO-450	450	462.0	7.20		6.00	7.00	470.0	26.2	26.0		6.0		1510.0	18.0	1388	1431.0	6.0	138.00
DHO-460	460	472.0	7.20		6.00	7.00	480.0	26.2	26.0		6.0		1550.0	18.0	1360	1464.0	6.0	135.00

ALL DIMENSIONS IN MILLIMETERS.

*The radius "R" on the load side must not exceed 0.1 T.

*** FOR PLATED RINGS, ADD 0.05 TO THE LISTED MAXIMUM THICKNESS.

MAXIMUM RING THICKNESS WILL BE A MINIMUM OF 0.005 LESS THAN THE LISTED GROOVE WIDTH (W) MINIMUM.

HARDNESS RANGES: CARBON STEEL RINGS (SAE 1060-1090)

RING TYPE	SIZE RANGE	HARDNESS		
		VICKERS	ROCKWELL	
			HRC	LOWER SCALE*
DHO	8-22	470-580	47-54	66-72 HR30N
	23-48	470-580	47-54	-
	50-200	435-530	44-51	-
	202-300	390-470	40-47	-
	305-1000	370-415	38-43	-

*WHERE APPLICABLE

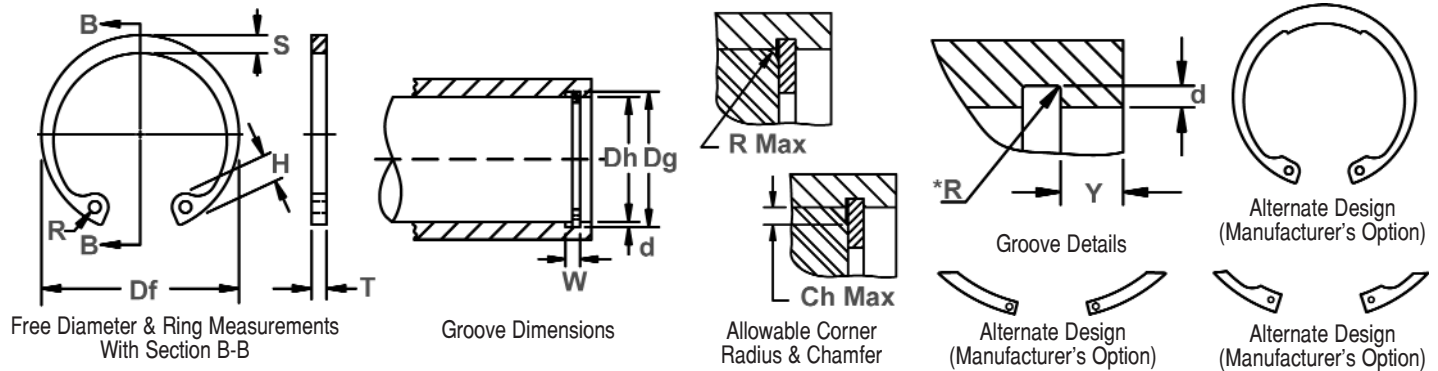

RING NO.	HOUSING Dia. (mm)	GROOVE SIZE						RINGS SIZE & WEIGHT						SUPPLEMENTARY DATA					
		DIAMETER		WIDTH	DEPTH		THICKNESS ***		FREE DIAMETER		LUG HT.	MAX. SEC.	HOLE DIA.	WEIGHT	EDGE MARGIN	THRUST LOAD Ring	THRUST LOAD Groove	Allowable Rad./Cham.	Max. load w/ R/Ch Max.
		Dh	Dg	Tol.	W Min.	d	T	Tol.	Df	Tol.	H Max.	S Ref.	R Min.	kg/1000	Y Min.	Pr kN	Pg kN	R/Ch Max.	P'r kN
DHO-470	470	482,0		7,20	6,00	7,00		490,0	+2,00	26,2	26,0	6,0	1595,0	18,0	1330	1495	6,0	132,0	
DHO-480	480	492,0		7,20	6,00	7,00		500,0	-1,00	26,2	26,0	6,0	1640,0	18,0	1306	1526	6,0	130,0	
DHO-490	490	502,0		7,20	6,00	7,00		510,0		26,2	26,0	6,0	1685,0	18,0	1280	1558	6,0	127,0	
DHO-500	500	512,0		7,20	6,00	7,00		520,0		26,2	26,0	6,0	1730,0	18,0	1256	1588	6,0	125,0	
DHO-510	510	524,0		8,20	7,00	8,00		535,0		26,2	26,0	6,0	2250,0	21,0	1834	1894	7,0	156,0	
DHO-520	520	534,0		8,20	7,00	8,00		545,0		26,2	26,0	6,0	2290,0	21,0	1802	1931	7,0	153,0	
DHO-530	530	544,0		8,20	7,00	8,00	-0,15	555,0		26,2	26,0	6,0	2335,0	21,0	1768	1968	7,0	150,0	
DHO-540	540	554,0		8,20	7,00	8,00		565,0	+3,00	26,2	26,0	6,0	2380,0	21,0	1738	2004	7,0	148,0	
DHO-550	550	564,0		8,20	7,00	8,00		575,0	-1,50	26,2	26,0	6,0	2430,0	21,0	1711	2041	7,0	145,0	
DHO-560	560	574,0	+1,00	8,20	7,00	8,00		585,0		26,2	26,0	6,0	2495,0	21,0	1682	2078	7,0	143,0	
DHO-570	570	584,0		8,20	7,00	8,00		595,0		26,2	26,0	6,0	2560,0	21,0	1650	2114	7,0	141,0	
DHO-580	580	594,0		8,20	7,00	8,00		605,0		26,2	26,0	6,0	2625,0	21,0	1627	2151	7,0	138,0	
DHO-590	590	604,0		8,20	7,00	8,00		615,0		26,2	26,0	6,0	2700,0	21,0	1601	2188	7,0	136,0	
DHO-600	600	614,0		8,20	7,00	8,00		625,0		26,2	26,0	6,0	2770,0	21,0	1571	2221	7,0	134,0	
DHO-650	650	666,0		9,30	8,00	9,00		680,0		34,0	34,0	6,0	3600,0	24,0	2654	2753	7,0	226,0	
DHO-700**	700	716,0		9,30	8,00	9,00		730,0		34,0	34,0	6,0	4120,0	24,0	2471	2966	7,0	210,0	
DHO-750**	750	768,0		9,30	9,00	9,00		785,0		34,0	34,0	9,0	4540,0	27,0	2310	3566	7,0	196,0	
DHO-800**	800	818,0		9,30	9,00	9,00	-0,20	835,0	+4,00	34,0	34,0	9,0	5450,0	27,0	2176	3800	7,0	184,0	
DHO-850**	850	870,0		9,30	10,00	9,00		890,0	-2,00	34,0	34,0	9,0	5990,0	30,0	2045	4500	7,0	173,0	
DHO-900**	900	920,0		9,30	10,00	9,00		940,0		34,0	34,0	9,0	6740,0	30,0	1938	4766	7,0	164,0	
DHO-950**	950	972,0		9,30	11,00	9,00		1000,0		34,0	34,0	9,0	7930,0	33,0	1840	5608	7,0	156,0	
DHO-1000**	1000	1022,0		9,30	11,00	9,00		1050,0		34,0	34,0	9,0	8880,0	33,0	1752	5825	7,0	148,0	

ALL DIMENSIONS IN MILLIMETERS.

*The radius "R" on the load side must not exceed 0.1 T.

** THESE PARTS ARE MADE WITH A CONSTANT SECTION WIDTH (NO TAPER)

*** FOR PLATED RINGS, ADD 0.05 TO THE LISTED MAXIMUM THICKNESS.

MAXIMUM RING THICKNESS WILL BE A MINIMUM OF 0.005 LESS THAN THE LISTED GROOVE WIDTH (W) MINIMUM.

HARDNESS RANGES: STAINLESS STEEL RINGS (DIN 1.4122 X39CrMo17)

RING TYPE	SIZE RANGE	HARDNESS			
		HV	HRC	15N	30N
DHO	ALL	470-580	47-54	84-87.5	66-72

HARDNESS RANGES: STAINLESS STEEL RINGS (PH 15-7MO)

RING TYPE	SIZE RANGE	HARDNESS		
		VICKERS	ROCKWELL	
			HRC	LOWER SCALE*
DHO	8-22	435-530	44-51	63-69.5 HR30N
	23-1000	435-530	44-51	-

*WHERE APPLICABLE





DHI Housing Rings

Axially Assembled, Internal Inverted, Metric

Functions like an DHO ring in a housing/bore, only the lugs are "reversed." This version reduces the distance the lugs of the standard DHO extend into the inner circumference of the housing/bore and allows for another assembly to pass through unimpeded.

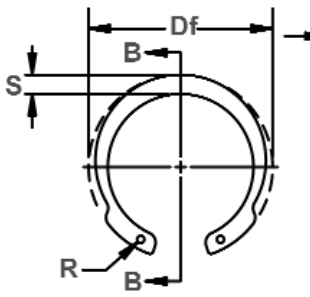

Free Diameter & Ring Measurements With Section B-B

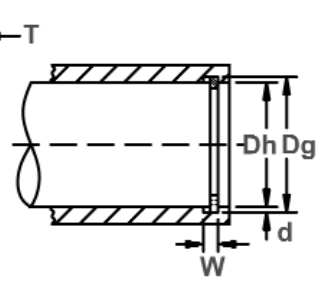

Housing Diameter & Groove Dimensions

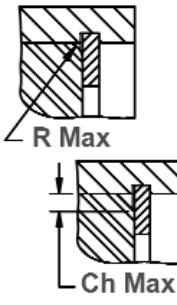

Allowable Corner Radius & Chamfer

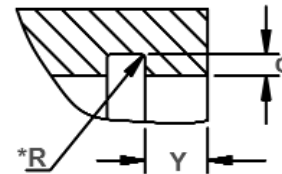

Exploded Groove Profile & Edge Margin (Y) *The radius "R" on the load side must not exceed 0.1T.

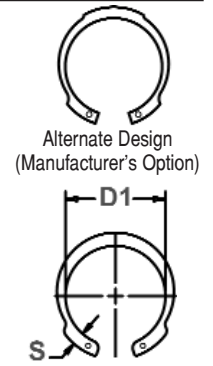

Alternate Design (Manufacturer's Option)

Measuring Free Diameter (Df) DHI Series $Df = D1 + 2S$

RING NO.	HOUSING DIAMETER		GROOVE SIZE				RING SIZE & WEIGHT						SUPPLEMENTARY DATA					
			DIAMETER		WIDTH	DEPTH	THICKNESS ***		FREE DIAMETER		MAX. SEC.	HOLE DIA.	WEIGHT	EDGE MARGIN	THRUST LOAD Ring	THRUST LOAD Groove	Allowable Rad./Cham.	Max. load w/ R/Ch. Max.
			Dh	Dg	Tol.	W Min.	d	T	Tol.	Df	Tol.	S	Tol.	R Min.	kg/1000	Y Min.	Pr kN	Pg kN
DHI-12	12	12.6		0.70	0.30	0.60	-0.05	13.1		1.8		1.0	0.25	0.9	1.8	0.75	0.8	1.0
DHI-15	15	15.7	+0.11	0.90	0.35	0.80		16.1		2.0		1.0	0.41	1.0	3.3	1.33	1.0	1.9
DHI-16	16	16.8		1.10	0.40	1.00		17.3		2.1		1.3	0.53	1.2	5.2	1.67	1.0	3.1
DHI-17	17	17.8		1.10	0.40	1.00		18.3	+0.42	2.1		1.3	0.58	1.2	5.8	1.70	1.0	3.0
DHI-18	18	19.0		1.10	0.50	1.00		19.5	-0.13	2.2		1.3	0.62	1.5	6.3	1.78	1.0	3.0
DHI-19	19	20.0		1.10	0.50	1.00		20.5		2.2		1.3	0.66	1.5	6.6	2.50	1.0	2.8
DHI-20	20	21.0	+0.15	1.10	0.50	1.00		21.5		2.3		1.3	0.80	1.5	7.0	2.66	1.0	2.9
DHI-21	21	22.0		1.10	0.50	1.00		22.5		2.4		1.3	0.81	1.5	7.4	2.73	1.0	2.8
DHI-22	22	23.0		1.10	0.50	1.00		23.5		2.4		1.3	0.83	1.5	7.5	2.80	1.0	2.8
DHI-24	24	25.2		1.30	0.60	1.20		25.9		2.8	±0.1	1.5	1.30	1.8	14.5	3.68	1.0	4.8
DHI-25	25	26.2		1.30	0.60	1.20		26.9	+0.42	2.8		1.5	1.40	1.8	14.8	4.00	1.0	5.0
DHI-26	26	27.2	+0.21	1.30	0.60	1.20	-0.06	27.9	-0.21	3.0		1.5	1.50	1.8	15.3	4.17	1.0	5.2
DHI-27	27	28.4		1.30	0.70	1.20		29.1		3.0		1.5	1.53	2.1	15.0	5.00	1.0	5.1
DHI-28	28	29.4		1.30	0.70	1.20		30.1		3.1		1.5	1.80	2.1	15.3	5.10	1.0	5.2
DHI-30	30	31.4		1.30	0.70	1.20		32.1		3.2		1.5	2.03	2.1	14.9	5.50	1.0	5.1
DHI-32	32	33.7		1.30	0.85	1.20		34.4	+0.50	3.3		1.5	2.05	2.5	14.1	7.00	1.0	4.9
DHI-33	33	34.7		1.30	0.85	1.20		35.5	-0.25	3.3		1.5	2.35	2.5	13.8	7.30	1.0	4.8
DHI-34	34	35.7	+0.25	1.60	0.85	1.50		36.5		3.4		1.5	2.95	2.5	24.0	7.50	1.5	6.0
DHI-35	35	37.0		1.60	1.00	1.50		37.8		3.4		1.7	3.20	3.0	26.4	9.20	1.5	6.3
DHI-36	36	38.0		1.60	1.00	1.50		38.8		3.6		1.7	3.23	3.0	27.5	9.70	1.5	6.6
DHI-38	38	40.0		1.60	1.00	1.50		40.8		3.8		1.7	3.68	3.0	28.0	10.20	1.5	6.7

*** FOR PLATED RINGS, ADD 0.05 TO THE LISTED MAXIMUM THICKNESS. MAXIMUM RING THICKNESS WILL BE A MINIMUM OF 0.005 LESS THAN THE LISTED GROOVE WIDTH (W) MINIMUM.

ALL DIMENSIONS IN MILLIMETERS.

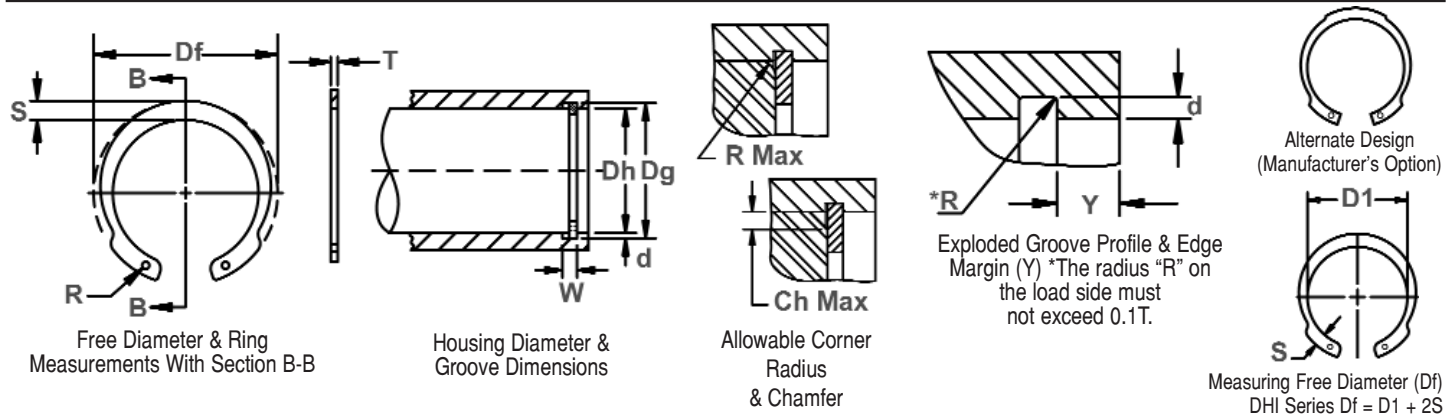

RING NO.	HOUSING DIAMETER	GROOVE SIZE					RING SIZE & WEIGHT						SUPPLEMENTARY DATA						
		DIAMETER		WIDTH		DEPTH	THICKNESS ***		FREE DIAMETER		MAX. SEC.		HOLE DIA.	WEIGHT	EDGE MARGIN	THRUST LOAD Ring	THRUST LOAD Groove	Allowable Rad./Cham.	Max. load w/ R/Ch. Max.
		Dh	Dg	Tol.	W Min.	d	T	Tol.	Df	Tol.	S	Tol.	R Min.	kg/1000	Y Min.	Pr kN	Pg kN	R/Ch. Max.	Pr kN
DHI-40	40	42.5	+0.25	1.85	1.25	1.75	-0.06	43.5	+0.90	4.2	±0.2	2.0	4.75	3.8	45.5	13.50	2.0	8.4	
DHI-42	42	44.5		1.85	1.25	1.75		45.5	-0.39	4.2		2.0	5.20	3.8	45.5	14.10	2.0	8.5	
DHI-45	45	47.5		1.85	1.25	1.75		48.5		4.2		2.0	6.00	3.8	44.0	15.00	2.0	8.4	
DHI-47	47	49.5	+0.30	1.85	1.25	1.75	-0.07	50.5	+1.10	4.7	±0.2	2.0	6.50	3.8	45.0	15.80	2.0	8.7	
DHI-48	48	50.5		1.85	1.25	1.75		51.5				4.7	2.0	7.00	3.8	48.0	16.00	2.0	9.1
DHI-50	50	53.0		2.15	1.50	2.00		54.2				5.2	2.5	8.50	4.5	69.0	20.00	2.0	13.4
DHI-52	52	55.0	+0.35	2.15	1.50	2.00	-0.08	56.2	+1.30	5.2	±0.3	2.5	9.00	4.5	66.5	20.80	2.0	13.3	
DHI-55	55	58.0		2.15	1.50	2.00		59.2				5.2	2.5	10.00	4.5	66.0	22.20	2.0	13.3
DHI-57	57	60.0		2.15	1.50	2.00		61.2				5.2	2.5	10.25	4.5	65.0	23.00	2.0	13.1
DHI-58	58	61.0	+0.35	2.15	1.50	2.00	-0.08	62.2	+1.30	5.2	±0.3	2.5	10.50	4.5	64.0	23.30	2.0	12.9	
DHI-60	60	63.0		2.15	1.50	2.00		64.2				5.2	2.5	11.25	4.5	62.0	24.20	2.0	12.7
DHI-62	62	65.0		2.15	1.50	2.00		66.2				5.2	2.5	11.75	4.5	60.0	25.00	2.0	12.3
DHI-65	65	68.0	+0.35	2.65	1.50	2.50	-0.08	69.2	+1.30	5.7	±0.3	2.5	16.25	4.5	122.0	25.80	2.5	20.6	
DHI-67	67	70.0		2.65	1.50	2.50		71.5				5.7	2.5	17.30	4.5	122.0	26.80	2.5	20.8
DHI-68	68	71.0		2.65	1.50	2.50		72.5				5.7	2.5	17.75	4.5	123.0	27.20	2.5	21.0
DHI-72	72	75.0	+0.35	2.65	1.50	2.50	-0.08	76.5	+1.30	6.0	±0.3	2.5	19.60	4.5	119.0	28.80	2.5	20.8	
DHI-80	80	83.5		2.65	1.75	2.50		85.5				6.0	2.5	22.90	5.3	110.0	37.40	2.5	19.6
DHI-85	85	88.5		3.15	1.75	3.00		90.5				6.6	3.0	30.00	5.3	176.0	39.70	3.0	27.2
DHI-90	90	93.5	+0.35	3.15	1.75	3.00	-0.08	95.5	+1.30	6.6	±0.3	3.0	33.00	5.3	169.0	42.00	3.0	26.6	
DHI-95	95	98.5		3.15	1.75	3.00		100.5				7.4	3.0	37.50	5.3	168.0	43.50	3.0	27.0
DHI-100	100	103.5		3.15	1.75	3.00		105.5				7.4	3.0	41.90	5.3	165.0	46.70	3.0	26.8

*** FOR PLATED RINGS, ADD 0.05 TO THE LISTED MAXIMUM THICKNESS. MAXIMUM RING THICKNESS WILL BE A MINIMUM OF 0.005 LESS THAN THE LISTED GROOVE WIDTH (W) MINIMUM.

ALL DIMENSIONS IN MILLIMETERS.

HARDNESS RANGES: STAINLESS STEEL RINGS (DIN 1.4122 X39CrMo17)

RING TYPE	SIZE RANGE	HARDNESS			
		HV	HRC	15N	30N
DHI	ALL	470-580	47-54	84-87.5	66-72

HARDNESS RANGES: CARBON STEEL RINGS (SAE 1060-1090)

RING TYPE	SIZE RANGE	HARDNESS		
		VICKERS	ROCKWELL	
			HRC	LOWER SCALE*
DHI	12-22	470-580	47-54	66-72 HR30N
	23-48	470-580	47-54	-
	50-100	435-530	44-51	-

*WHERE APPLICABLE



DHT Housing Rings

(DIN 984)

Axially Assembled, Internal Teeth, Metric

Similar in design to the DHO internal ring, this features several "teeth" equally distributed along the circumference of the ring. The increased shoulder offered by the teeth is particularly effective in retaining applications with large radii or chamfers.

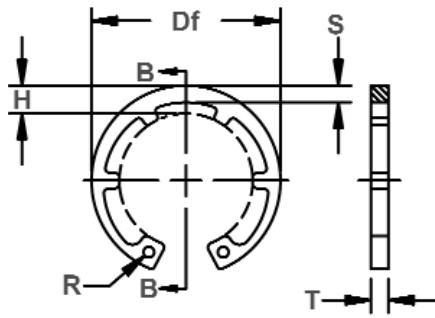

Free Diameter and Ring Measurements With Section B-B

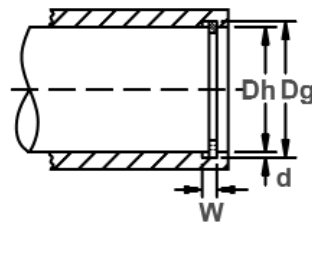

Housing Diameter & Groove Dimensions

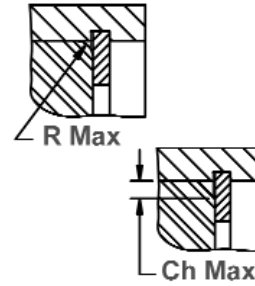

Allowable Corner Radius & Chamfer

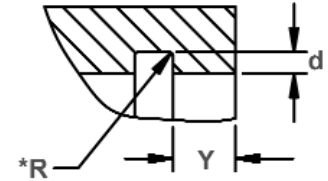

Exploded Groove Profile & Edge Margin (Y)
*The radius "R" on the load side must not exceed 0.1T.

RING NO.	HOUSING DIA.		GROOVE SIZE			RING SIZE & WEIGHT							SUPPLEMENTARY DATA					
			DIAMETER	WIDTH	DEPTH	THICKNESS ***		FREE DIAMETER		LUG HT.	MAX. SEC.	HOLE DIA.	WEIGHT	EDGE MARGIN	THRUST LOAD Ring	THRUST LOAD Groove	Allowable Rad/ Cham.	Max. load w/ R/Ch. Max.
						T	Tol.	Df	Tol.									
DHT-16	16	16.8	+0,11	1,10	0,40	1,00		17,3		3,4	2,1	1,7	0,72	1,2	5,5	3,4	1,0	2,5
DHT-17	17	17,8		1,10	0,40	1,00		18,3		3,7	2,2	1,7	0,80	1,2	6,0	3,6	1,0	2,5
DHT-18	18	19,0		1,10	0,50	1,00		19,5		4,1	2,3	2,0	0,90	1,5	6,5	4,8	1,0	2,6
DHT-19	19	20,0		1,10	0,50	1,00		20,5	+0,42	3,8	2,3	2,0	0,99	1,5	6,8	5,1	1,0	2,6
DHT-20	20	21,0	+0,15	1,10	0,50	1,00		21,5	-0,13	3,9	2,4	2,0	1,06	1,5	7,2	5,4	1,0	2,6
DHT-21	21	22,0		1,10	0,50	1,00		22,5		4,0	2,4	2,0	1,17	1,5	7,6	5,7	1,0	2,6
DHT-22	22	23,0		1,10	0,50	1,00		23,5		4,0	2,6	2,0	1,28	1,5	8,0	5,9	1,0	2,7
DHT-23	23	24,1		1,30	0,55	1,20		24,6		4,1	2,6	2,0	1,48	1,6	13,8	6,8	1,0	4,5
DHT-24	24	25,2		1,30	0,60	1,20		25,9		4,2	2,6	2,0	1,60	1,8	13,9	7,7	1,0	4,6
DHT-25	25	26,2		1,30	0,60	1,20		26,9	+0,42	4,4	2,8	2,0	1,72	1,8	14,6	8,0	1,0	4,7
DHT-26	26	27,2	+0,21	1,30	0,60	1,20		28,5	-0,21	4,4	2,8	2,0	2,00	1,8	13,8	8,4	1,0	4,6
DHT-27	27	28,4		1,30	0,70	1,20		29,1		4,5	2,9	2,0	2,00	2,1	13,3	10,1	1,0	4,5
DHT-28	28	29,4		1,30	0,70	1,20	-0,06	30,1		4,9	3,0	2,0	2,10	2,1	13,3	10,5	1,0	4,5
DHT-30	30	31,4		1,30	0,70	1,20		32,1		4,9	3,2	2,0	2,35	2,1	13,7	11,3	1,0	4,6
DHT-31	31	32,7		1,30	0,85	1,20		33,4		5,0	3,2	2,5	2,42	2,5	13,8	14,1	1,0	4,7
DHT-32	32	33,7		1,30	0,85	1,20		34,4	+0,50	5,1	3,3	2,5	2,50	2,5	13,8	14,6	1,0	4,7
DHT-33	33	34,7		1,30	0,85	1,20		35,5	-0,25	5,1	3,3	2,5	2,65	2,5	14,3	15,0	1,5	4,9
DHT-34	34	35,7		1,60	0,85	1,50		36,5		5,3	3,4	2,5	3,80	2,5	26,2	15,4	1,5	6,3
DHT-35	35	37,0		1,60	1,00	1,50		37,8		5,5	3,6	2,5	4,00	3,0	26,9	18,8	1,5	6,4
DHT-36	36	38,0	+0,25	1,60	1,00	1,50		38,8		5,6	3,6	2,5	4,15	3,0	26,4	19,4	1,5	6,4
DHT-38	38	40,0		1,60	1,00	1,50		40,8		6,1	3,8	2,5	4,40	3,0	28,2	22,5	1,5	6,7
DHT-40	40	42,5		1,85	1,25	1,75		43,5		7,2	4,0	2,5	5,30	3,8	44,6	27,0	2,0	8,3
DHT-42	42	44,5		1,85	1,25	1,75		45,5	+0,90	7,2	4,1	2,5	6,00	3,8	44,7	28,4	2,0	8,4
DHT-44	44	46,5		1,85	1,25	1,75		47,5	-0,39	7,2	4,2	2,5	6,45	3,8	43,3	29,5	2,0	8,3
DHT-45	45	47,5		1,85	1,25	1,75		48,5		7,2	4,3	2,5	6,60	3,8	43,1	30,2	2,0	8,2
DHT-47	47	49,5		1,85	1,25	1,75		50,5	+1,10	7,2	4,5	2,5	6,90	3,8	43,5	31,4	2,0	8,3
DHT-48	48	50,5	+0,30	1,85	1,25	1,75		51,5	-0,46	7,2	4,5	2,5	7,50	3,8	43,2	32,0	2,0	8,4

*** FOR PLATED RINGS, ADD 0.05 TO THE LISTED MAXIMUM THICKNESS. MAXIMUM RING THICKNESS WILL BE A MINIMUM OF 0.005 LESS THAN THE LISTED GROOVE WIDTH (W) MINIMUM.
ALL DIMENSIONS IN MILLIMETERS.

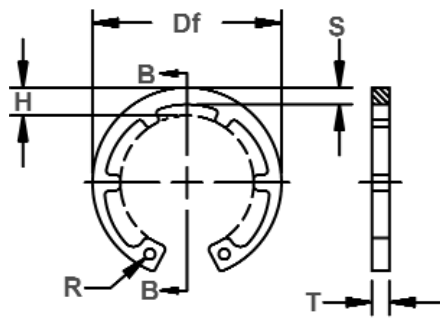

Free Diameter and Ring Measurements With Section B-B

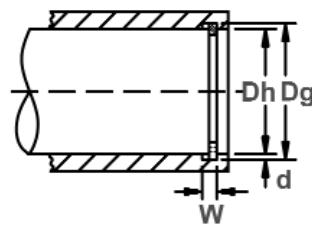

Housing Diameter & Groove Dimensions

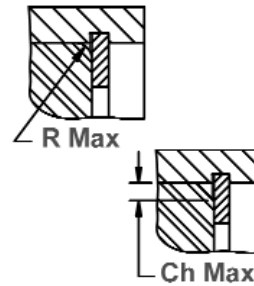

Allowable Corner Radius & Chamfer

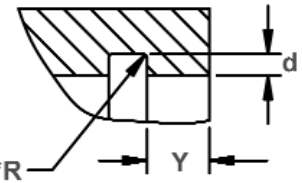

Exploded Groove Profile & Edge Margin (Y)
*The radius "R" on the load side must not exceed 0.1T.

RING NO.	HOUSING DIA.		GROOVE SIZE					RING SIZE & WEIGHT					SUPPLEMENTARY DATA						
			DIAMETER		WIDTH	DEPTH	THICKNESS ***		FREE DIAMETER		LUG HT.	MAX. SEC.	HOLE DIA.	WEIGHT	EDGE MARGIN	THRUST LOAD Ring	THRUST LOAD Groove	Allowable Rad/ Cham.	Max. load w/ R/Ch. Max.
			Dh	Dg	Tol.	W Min.	d	T	Tol.	Df	Tol.	H Max.	S Ref.	R Min.	kg/ 1000	Y Min.	Pr kN	Pg kN	R/Ch Max.
DHT-50	50	53.0		2,15	1,50	2,00		54,2		8,2	4,7	2,5	8,50	4,5	60,8	40,5	2,0	12,1	
DHT-52	52	55,0		2,15	1,50	2,00		56,2		8,2	4,7	2,5	9,40	4,5	60,2	42,0	2,0	12,0	
DHT-55	55	58,0		2,15	1,50	2,00		59,2		8,2	5,1	2,5	9,75	4,5	60,3	44,4	2,0	12,5	
DHT-57	57	60,0		2,15	1,50	2,00		61,2		8,2	5,2	2,5	11,65	4,5	60,8	46,0	2,0	12,7	
DHT-58	58	61,0		2,15	1,50	2,00		62,2	+1,10	8,2	5,3	2,5	12,00	4,5	60,8	46,7	2,0	12,7	
DHT-60	60	63,0	+0,30	2,15	1,50	2,00	-0,07	64,2	-0,46	8,2	5,5	2,5	12,70	4,5	61,0	48,3	2,0	13,0	
DHT-62	62	65,0		2,15	1,50	2,00		66,2		8,2	5,6	2,5	12,75	4,5	60,9	49,8	2,0	13,0	
DHT-65	65	68,0		2,65	1,50	2,50		69,2		10,2	5,8	3,0	16,70	4,5	121,0	51,8	2,5	20,8	
DHT-67	67	70,0		2,65	1,50	2,50		71,5		10,2	6,0	3,0	18,60	4,5	121,0	53,8	2,5	21,1	
DHT-68	68	71,0		2,65	1,50	2,50		72,5		10,2	6,1	3,0	19,30	4,5	121,0	54,5	2,5	21,2	
DHT-70	70	73,0		2,65	1,50	2,50		74,5		10,2	6,2	3,0	20,20	4,5	119,0	56,2	2,5	21,0	
DHT-72	72	75,0		2,65	1,50	2,50		76,5		10,2	6,4	3,0	21,20	4,5	119,0	58,0	2,5	21,0	
DHT-75	75	78,0		2,65	1,50	2,50		79,5		10,2	6,6	3,0	22,60	4,5	118,0	60,0	2,5	21,0	
DHT-80	80	83,5		2,65	1,75	2,50		85,5		10,2	7,0	3,0	25,00	5,3	120,0	74,6	2,5	21,8	
DHT-85	85	88,5		3,15	1,75	3,00		90,5		12,2	7,4	3,5	30,10	5,3	201,0	79,5	3,0	31,2	
DHT-90	90	93,5	+0,35	3,15	1,75	3,00	-0,08	95,5	+1,30	12,2	7,7	3,5	35,50	5,3	199,0	84,0	3,0	31,4	
DHT-95	95	98,5		3,15	1,75	3,00		100,5	-0,54	12,2	8,1	3,5	40,00	5,3	195,0	88,6	3,0	31,4	
DHT-100	100	103,5		3,15	1,75	3,00		105,5		12,2	8,5	3,5	43,50	5,3	188,0	93,1	3,0	30,8	
DHT-110	110	114,0	+0,54	4,15	2,00	4,00		117,0		12,2	9,0	3,5	73,00	6,0	415,0	117,0	3,0	71,0	
DHT-115	115	119,0		4,15	2,00	4,00		122,0		12,2	9,3	3,5	82,00	6,0	409,0	122,0	3,0	71,2	
DHT-120	120	124,0		4,15	2,00	4,00		127,0		12,2	9,6	3,5	87,00	6,0	396,0	127,0	3,0	70,0	
DHT-125	125	129,0		4,15	2,00	4,00		132,0		12,2	9,9	4,0	92,00	6,0	385,0	132,0	3,0	70,0	
DHT-130	130	134,0		4,15	2,00	4,00		137,0	+1,50	12,2	10,2	4,0	102,00	6,0	374,0	138,0	3,0	69,0	
DHT-140	140	144,0	+0,63	4,15	2,00	4,00	-0,10	148,0	-0,63	14,2	10,7	4,0	112,00	6,0	350,0	148,0	3,0	66,5	
DHT-150	150	155,0		4,15	2,50	4,00		158,0		14,2	11,1	4,0	123,00	7,5	326,0	191,0	3,0	64,0	
DHT-160	160	165,0		4,15	2,50	4,00		169,0		14,2	11,8	4,5	133,00	7,5	321,0	212,0	3,5	54,5	
DHT-170	170	175,0		4,15	2,50	4,00		179,0		14,2	12,3	4,5	145,00	7,5	349,0	225,0	3,5	59,0	

*** FOR PLATED RINGS, ADD 0.05 TO THE LISTED MAXIMUM THICKNESS. MAXIMUM RING THICKNESS WILL BE A MINIMUM OF 0.005 LESS THAN THE LISTED GROOVE WIDTH (W) MINIMUM.
ALL DIMENSIONS IN MILLIMETERS.

NUMBER OF TEETH (INCLUDING LUGS)

RING TYPE	SIZE RANGE	#TEETH
DHT	16-58	6
	60-170	8

HARDNESS RANGES: CARBON STEEL RINGS (SAE 1060-1090)

RING TYPE	SIZE RANGE	HARDNESS		
		VICKERS	ROCKWELL	
			HRC	LOWER SCALE*
DHT	16-22	470-580	47-54	66-72 HR30N
	23-48	470-580	47-54	-
	50-170	435-530	44-51	-

*WHERE APPLICABLE

HARDNESS RANGES: STAINLESS STEEL RINGS (DIN 1.4122 X39CrMo17)

RING TYPE	SIZE RANGE	HARDNESS			
		HV	HRC	15N	30N
DHT	ALL	470-580	47-54	84-87.5	66-72





DHR Housing Rings

DIN 472 - Heavy Type

Axially Assembled, Internal Reinforced, Metric

A thicker version of the DHO featuring a larger radial width than this ring. Once installed in the groove of a housing/bore, the portion of the ring protruding from the groove (also called a "shoulder") holds an assembly in place.

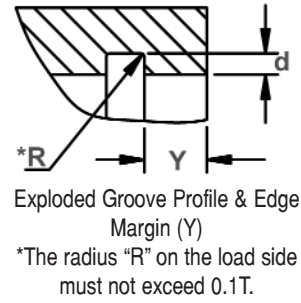
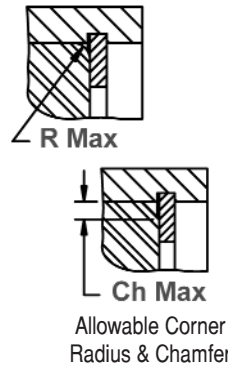
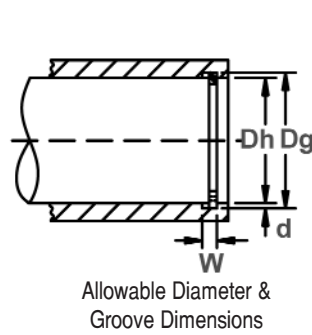
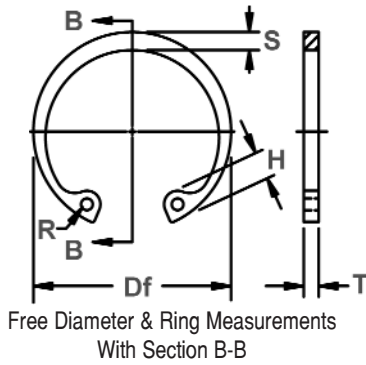

*The radius "R" on the load side must not exceed 0.1T.



RING NO.	HOUSING DIA.	GROOVE SIZE				RING SIZE & WEIGHT						SUPPLEMENTARY DATA						
		DIAMETER		WIDTH	DEPTH	THICKNESS ***		FREE DIAMETER		LUG HT.	MAX. SEC.	HOLE DIA.	WEIGHT	EDGE MARGIN	THRUST LOAD Ring	THRUST LOAD Groove	Allowable Rad/ Cham.	Max. load w/ R/Ch. Max.
		Dh	Dg	Tol.	W Min.	d	T	Tol.	Df	Tol.	H Max.	S Ref.	R Min.	kg/ 1000	Y Min.	Pr kN	Pg kN	R/Ch Max.
DHR-20	20	21.0	+0,15	1,60	0,50	1,50		21,5		4,5	2,4	2,0	1,4	1,5	16,2	5,4	1,0	5,8
DHR-22	22	23,0		1,60	0,50	1,50		23,5	+0,42	4,7	2,8	2,0	1,9	1,5	18,0	5,9	1,0	6,1
DHR-24	24	25,2		1,60	0,60	1,50		25,9	-0,21	4,9	3,0	2,0	2,0	1,8	21,7	7,7	1,0	7,2
DHR-25	25	26,2		1,60	0,60	1,50		26,9		5,0	3,1	2,0	2,1	1,8	22,8	8,0	1,0	7,3
DHR-26	26	27,2	+0,21	1,60	0,60	1,50		27,9		5,1	3,1	2,0	2,3	1,8	21,6	8,4	1,0	7,2
DHR-27	27	28,4		1,60	0,70	1,50		29,1		5,1	3,2	2,0	2,4	2,1	20,8	10,1	1,0	7,0
DHR-28	28	29,4		1,60	0,70	1,50	-0,06	30,1		5,3	3,2	2,0	2,5	2,1	20,8	10,5	1,0	7,0
DHR-30	30	31,4		1,60	0,70	1,50		32,1		5,5	3,3	2,0	2,7	2,1	21,4	11,3	1,0	7,2
DHR-32	32	33,7		1,60	0,85	1,50		34,4	+0,50	5,7	3,4	2,0	2,9	2,6	21,4	14,6	1,0	7,3
DHR-34	34	35,7		1,85	0,85	1,75		36,5	-0,25	5,9	3,7	2,5	4,1	2,6	35,6	15,4	1,5	8,6
DHR-35	35	37,0		1,85	1,00	1,75		37,8		6,0	3,8	2,5	4,5	3,0	36,6	18,8	1,5	8,7
DHR-37	37	39,0	+0,25	1,85	1,00	1,75		39,8		6,2	3,9	2,5	4,7	3,0	36,6	19,8	1,5	8,8
DHR-38	38	40,0		1,85	1,00	1,75		40,8		6,3	3,9	2,5	4,8	3,0	38,3	22,5	1,5	9,1
DHR-40	40	42,5		2,15	1,25	2,00		43,5	+0,90	6,5	3,9	2,5	5,1	3,8	58,4	27,0	2,0	10,9
DHR-42	42	44,5		2,15	1,25	2,00		45,5	-0,39	6,7	4,1	2,5	5,6	3,8	58,5	28,4	2,0	11,0
DHR-45	45	47,5		2,15	1,25	2,00		48,5		7,0	4,3	2,5	6,3	3,8	56,5	30,2	2,0	10,7
DHR-47	47	49,5		2,15	1,25	2,00	-0,07	50,5		7,2	4,4	2,5	6,7	3,8	57,0	31,4	2,0	10,8
DHR-50	50	53,0		2,65	1,50	2,50		54,2		7,5	4,6	2,5	8,8	4,5	95,5	40,5	2,0	19,0
DHR-52	52	55,0		2,65	1,50	2,50		56,2		7,7	4,7	2,5	9,9	4,5	94,6	42,0	2,0	18,8
DHR-55	55	58,0		2,65	1,50	2,50		59,2		8,0	5,0	2,5	10,4	4,5	94,7	44,4	2,0	19,6
DHR-60	60	63,0		3,15	1,50	3,00		64,2	+1,10	8,5	5,4	2,5	15,9	4,5	137,0	48,3	2,0	29,2
DHR-62	62	65,0	+0,30	3,15	1,50	3,00		66,2	-0,46	8,6	5,5	2,5	16,1	4,5	137,0	49,8	2,0	29,2
DHR-64	64	67,0		3,15	1,50	3,00		68,2		8,7	5,6	3,0	16,5	4,5	137,0	51,4	2,0	30,0
DHR-65	65	68,0		3,15	1,50	3,00	-0,08	69,2		8,7	5,8	3,0	16,6	4,5	174,0	51,8	2,5	30,0
DHR-68	68	71,0		3,15	1,50	3,00		72,5		8,8	6,1	3,0	17,2	4,5	174,0	54,5	2,5	30,6
DHR-70	70	73,0		3,15	1,50	3,00		74,5		9,0	6,2	3,0	18,0	4,5	171,0	56,2	2,5	30,3
DHR-72	72	75,0		3,15	1,50	3,00		76,5		9,2	6,4	3,0	21,7	4,5	172,0	58,0	2,5	30,3
DHR-75	75	78,0		3,15	1,50	3,00		79,5		9,3	6,6	3,0	22,6	4,5	170,0	60,0	2,5	30,3
DHR-80	80	83,5		4,15	1,75	4,00		85,5		9,5	7,0	3,0	33,2	5,3	308,0	74,6	2,5	56,0
DHR-85	85	88,5	+0,35	4,15	1,75	4,00		90,5	+1,30	9,7	7,2	3,5	33,8	5,3	358,0	79,5	3,0	55,0
DHR-90	90	93,5		4,15	1,75	4,00	-0,10	95,5	-0,54	10,0	7,6	3,5	41,3	5,3	354,0	84,0	3,0	56,0
DHR-95	95	98,5		4,15	1,75	4,00		100,5		10,3	8,1	3,5	46,7	5,3	347,0	88,6	3,0	56,0
DHR-100	100	103,5		4,15	1,75	4,00		105,5		10,5	8,4	3,5	50,7	5,3	335,0	93,1	3,0	55,0

*** FOR PLATED RINGS, ADD 0.05 TO THE LISTED MAXIMUM THICKNESS. MAXIMUM RING THICKNESS WILL BE A MINIMUM OF 0.005 LESS THAN THE LISTED GROOVE WIDTH (W) MINIMUM.

ALL DIMENSIONS IN MILLIMETERS.

HARDNESS RANGES: CARBON STEEL RINGS (SAE 1060-1090)

RING TYPE	SIZE RANGE	HV	HRC
DHR	20-48	470-580	47-54
	50-100	435-530	44-51

HARDNESS RANGES: STAINLESS STEEL RINGS (DIN 1.4122 X39CrMo17)

RING TYPE	SIZE RANGE	HARDNESS			
		HV	HRC	15N	30N
DHR	ALL	470-580	47-54	84-87.5	66-72



Axially Assembled, External Reinforced, Metric

The DSR is an extra thick version of a regular DSH retaining ring. As such, it is stronger and can withstand greater thrust loads than its standard counterpart.

DSR Shaft Rings

DIN 471 - Heavy Type

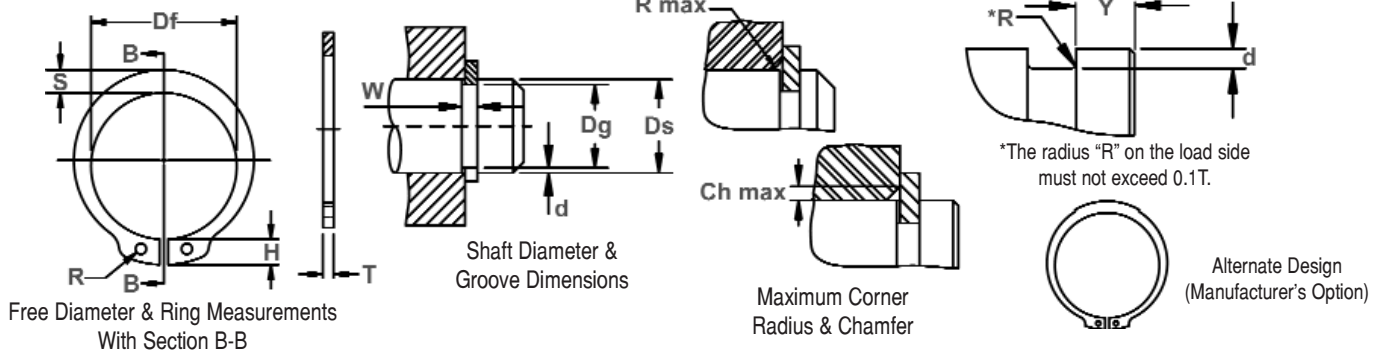

RING NO.	SHAFT DIA.	GROOVE SIZE			RING SIZE & WEIGHT						SUPPLEMENTARY DATA								
		DIAMETER		WIDTH	DEPTH	THICKNESS ***		FREE DIAMETER		LUG HT.	MAX. SEC.	HOLE DIA.	WEIGHT	EDGE MARGIN	THRUST LOAD Ring	THRUST LOAD Groove	Allowable Rad/Cham.	Max. load w/ R/Ch. Max.	RPM Limits
		Ds	Dg	Tol.	W Min.	d	T	Tol.	Df	Tol.	H Max.	S Ref.	R Min.	Kg/1000	Y Min.	Pr kN	Pg kN	R/Ch Max.	Pr kN
DSR-12	12	11.5	-0.11	1.60	0.25	1.50	-0.06	11.0	+0.10 -0.36	3.4	1.8	1.7	0.75	0.7	11.30	1.53	1.0	4.5	75000
DSR-15	15	14.3		1.60	0.35	1.50		13.8		4.8	2.4	2.0	1.20	0.7	15.50	3.20	1.0	4.5	50000
DSR-16	16	15.2		1.60	0.40	1.50		14.7		5.0	2.5	2.0	1.20	1.2	16.70	3.26	1.0	4.5	48000
DSR-17	17	16.2		1.60	0.40	1.50		15.7		5.0	2.6	2.0	1.24	1.2	18.00	4.32	1.0	4.5	46000
DSR-18	18	17.0		1.60	0.50	1.50		16.5		5.1	2.7	2.0	1.54	1.5	26.60	5.50	1.5	5.8	43000
DSR-19	19	18.0	-0.13	1.60	0.50	1.50	-0.06	17.5	+0.21 -0.42	5.1	2.7	2.0	1.45	1.5	26.60	5.78	1.5	5.9	28000
DSR-20	20	19.0		1.85	0.50	1.75		18.5		5.5	3.0	2.0	2.25	1.5	36.30	5.60	1.5	8.2	32000
DSR-22	22	21.0		1.85	0.50	1.75		20.5		6.0	3.1	2.0	2.30	1.5	36.00	5.60	1.5	8.1	29000
DSR-24	24	22.9		1.85	0.55	1.75		22.2		6.3	3.2	2.0	2.70	1.7	34.20	7.95	1.5	7.6	29000
DSR-25	25	23.9		2.15	0.55	2.00		23.2		6.4	3.4	2.0	3.35	1.7	45.00	8.30	1.5	10.3	25000
DSR-26	26	24.4	-0.21	2.15	0.80	2.00	-0.07	23.6	+0.25 -0.50	6.6	3.3	2.0	3.65	2.4	44.00	10.70	1.5	10.0	27000
DSR-27	27	25.5		2.15	0.75	2.00		24.7		6.6	3.4	2.0	3.85	2.3	45.50	10.30	1.5	10.6	25000
DSR-28	28	26.6		2.15	0.70	2.00		25.9		6.5	3.5	2.0	3.90	2.1	57.00	10.00	1.5	13.4	22000
DSR-29	29	27.6		2.15	0.70	2.00		26.9		6.5	3.8	2.0	4.30	2.1	56.50	10.40	1.5	13.3	22000
DSR-30	30	28.6		2.15	0.70	2.00		27.9		6.5	4.1	2.0	5.00	2.1	57.00	10.70	1.5	13.6	21000
DSR-32	32	30.3	-0.25	2.15	0.85	2.00	-0.07	29.6	+0.39 -0.90	6.5	4.1	2.5	5.40	2.5	57.00	12.90	1.5	13.6	20000
DSR-34	34	32.3		2.65	0.85	2.50		31.5		6.6	4.2	2.5	6.80	2.5	87.00	16.40	1.5	15.6	18000
DSR-35	35	33.0		2.65	1.00	2.50		32.2		6.7	4.2	2.5	7.10	3.0	86.00	17.80	1.5	15.4	17000
DSR-36	36	34.0		2.65	1.00	2.50		33.2		6.7	4.2	2.5	7.50	3.0	101.50	20.10	2.0	18.3	16000
DSR-38	38	36.0		2.65	1.00	2.50		35.2		6.8	4.3	2.5	8.00	3.0	101.00	21.20	2.0	18.6	15000
DSR-40	40	37.5	-0.25	2.65	1.25	2.50	-0.08	36.5	+0.46 -1.10	7.0	4.4	2.5	8.20	3.8	104.00	25.30	2.0	19.3	14000
DSR-42	42	39.5		2.65	1.25	2.50		38.5		7.2	4.5	2.5	9.60	3.8	102.00	26.70	2.0	19.2	13000
DSR-44	44	41.5		2.65	1.25	2.50		40.5		7.2	4.5	2.5	10.40	3.8	101.00	27.90	2.0	19.1	12000
DSR-45	45	42.5		2.65	1.25	2.50		41.5		7.5	4.7	2.5	10.80	3.8	100.00	28.60	2.0	19.1	11000
DSR-48	48	45.5		2.65	1.25	2.50		44.5		7.8	5.0	2.5	12.20	3.8	101.00	30.70	2.0	19.5	10000
DSR-50	50	47.0	-0.30	3.15	1.50	3.00	-0.10	45.8	+0.54 -1.30	8.0	5.1	2.5	14.80	4.5	165.00	38.20	2.0	32.4	11000
DSR-52	52	49.0		3.15	1.50	3.00		47.8		8.2	5.2	2.5	15.40	4.5	165.00	39.70	2.5	26.0	10000
DSR-55	55	52.0		3.15	1.50	3.00		50.8		8.5	5.4	2.5	17.00	4.5	161.00	42.00	2.5	25.6	9000
DSR-58	58	55.0		3.15	1.50	3.00		53.8		8.8	5.6	2.5	19.40	4.5	160.00	44.30	2.5	26.0	8000
DSR-60	60	57.0		3.15	1.50	3.00		55.8		9.0	5.8	2.5	20.00	4.5	156.00	46.00	2.5	25.4	8000
DSR-65	65	62.0	-0.35	4.15	1.50	4.00	-0.10	60.8	+0.54 -1.30	9.3	6.3	3.0	31.00	4.5	346.00	49.80	2.5	58.0	7000
DSR-70	70	67.0		4.15	1.50	4.00		65.5		9.5	6.6	3.0	32.20	4.5	343.00	53.80	2.5	59.0	7000
DSR-75	75	72.0		4.15	1.50	4.00		70.5		9.7	7.0	3.0	39.80	4.5	333.00	57.60	2.5	58.0	6000
DSR-80	80	76.5		4.15	1.75	4.00		74.5		9.8	7.4	3.0	42.40	5.3	328.00	71.60	3.0	50.0	6000
DSR-85	85	81.5		4.15	1.75	4.00		79.5		10.0	7.8	3.5	47.00	5.3	383.00	76.30	3.0	59.4	6000
DSR-90	90	86.5	-0.35	4.15	1.75	4.00	-0.10	84.5	+0.54 -1.30	10.2	10.2	3.5	55.60	5.3	386.00	80.80	3.0	61.0	5000
DSR-95	95	91.5		4.15	1.75	4.00		89.5		10.2	8.6	3.5	61.20	5.3	378.00	85.50	3.5	52.0	5000
DSR-100	100	96.5		4.15	1.75	4.00		94.5		10.5	9.0	3.5	72.00	5.3	368.00	90.00	3.5	51.6	4000

*** FOR PLATED RINGS, ADD 0.05 TO THE LISTED MAXIMUM THICKNESS. MAXIMUM RING THICKNESS WILL BE A MINIMUM OF 0.005 LESS THAN THE LISTED GROOVE WIDTH (W) MINIMUM. ALL DIMENSIONS IN MILLIMETERS.

HARDNESS RANGES: CARBON STEEL RINGS (SAE 1060-1090)

RING TYPE	SIZE RANGE	HV	HRC
DSR	12-48	470-580	47-54
	50-100	435-530	44-51

HARDNESS RANGES: STAINLESS STEEL RINGS (DIN 1.4122 X39CrMo17)

RING TYPE	SIZE RANGE	HARDNESS			
		HV	HRC	15N	30N
DSR	ALL	470-580	47-54	84-87.5	66-72





DSH Shaft Rings

(DIN 471)

Axially Assembled, External, Metric

Once installed in the groove of a shaft, the portion of the ring protruding from the groove (also called a "shoulder") holds an assembly in place.

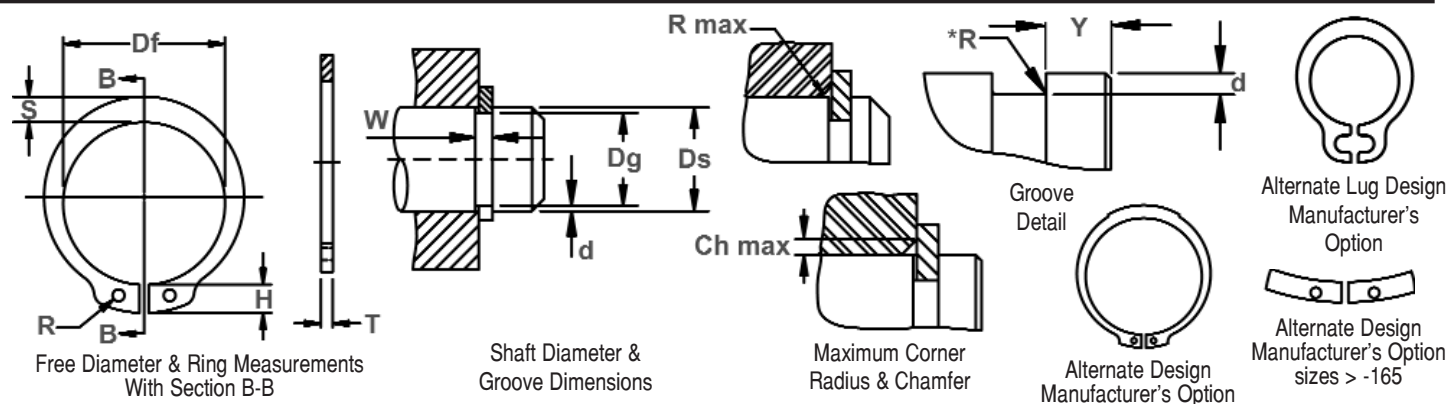

RING NO.	SHAFT DIA. (mm)	GROOVE SIZE					RING SIZE & WEIGHT							SUPPLEMENTARY DATA					
		DIAMETER	WIDTH	DEPTH	THICKNESS ***		FREE DIAMETER		LUG HT.	MAX. SEC.	HOLE DIA.	WEIGHT	EDGE MARGIN	THRUST LOAD Ring	THRUST LOAD Groove	Allowable Rad/Cham.	Max. Load w/Ch Max.	RPM Limits	
					Ds	Dg	TOL.	W Min.											d
DSH-3	3	2.8	-0.04	0.50	0.10	0.40	-0.05	2.7	+0.04	H Max.	S Ref.	R Min.	kg/1000	Y Min.	Pr kN	Pg kN	R/Ch Max.	P'r kN	360000
DSH-4	4	3.8		0.50	0.10	0.40		3.7		2.2	0.9	1.0	0.017	0.3	0.47	0.1	0.5	0.27	
DSH-5	5	4.8	-0.06	0.70	0.10	0.60	-0.05	4.7	-0.15	2.5	1.1	1.0	0.066	0.3	1.00	0.2	0.5	0.80	154000
DSH-6	6	5.7		0.80	0.15	0.70		5.6		2.7	1.3	1.2	0.084	0.5	1.45	0.4	0.5	0.90	
DSH-7	7	6.7	-0.06	0.90	0.15	0.80	-0.06	6.5	+0.06	3.1	1.4	1.2	0.121	0.5	2.60	0.5	0.5	1.40	121000
DSH-8	8	7.6		0.90	0.20	0.80		7.4		3.2	1.5	1.2	0.158	0.6	3.00	0.8	0.5	2.00	
DSH-9	9	8.6	-0.11	1.10	0.20	1.00	-0.06	8.4	-0.18	3.3	1.7	1.2	0.300	0.6	3.50	0.9	0.5	2.40	85000
DSH-10	10	9.6		1.10	0.20	1.00		9.3		3.3	1.8	1.5	0.340	0.6	4.00	1.0	1.0	2.40	
DSH-11	11	10.5	-0.11	1.10	0.25	1.00	-0.06	10.2	+0.10	3.3	1.8	1.5	0.410	0.8	4.50	1.4	1.0	2.40	70000
DSH-12	12	11.5		1.10	0.25	1.00		11.0		3.3	1.8	1.7	0.500	0.8	5.00	1.5	1.0	2.40	
DSH-13	13	12.4	-0.11	1.10	0.30	1.00	-0.06	11.9	-0.36	3.4	2.0	1.7	0.530	0.9	5.80	2.0	1.0	2.40	66000
DSH-14	14	13.4		1.10	0.30	1.00		12.9		3.5	2.1	1.7	0.640	0.9	6.40	2.1	1.0	2.40	
DSH-15	15	14.3	-0.13	1.10	0.35	1.00	-0.06	13.8	+0.13	3.6	2.2	1.7	0.670	1.1	6.90	2.6	1.0	2.40	50000
DSH-16	16	15.2		1.10	0.40	1.00		14.7		3.7	2.2	1.7	0.700	1.2	7.40	3.2	1.0	2.40	
DSH-17	17	16.2	-0.15	1.10	0.40	1.00	-0.06	15.7	-0.42	3.8	2.3	1.7	0.820	1.2	8.00	3.4	1.0	2.40	41000
DSH-18	18	17.0		1.30	0.50	1.20		16.5		3.9	2.4	2.0	1.110	1.5	17.00	4.5	1.5	3.75	
DSH-19	19	18.0	-0.13	1.30	0.50	1.20	-0.06	17.5	+0.13	3.9	2.5	2.0	1.220	1.5	17.00	4.8	1.5	3.80	35000
DSH-20	20	19.0		1.30	0.50	1.20		18.5		4.0	2.6	2.0	1.300	1.5	17.10	5.0	1.5	3.85	
DSH-21	21	20.0	-0.15	1.30	0.50	1.20	-0.06	19.5	-0.42	4.1	2.7	2.0	1.420	1.5	16.80	5.3	1.5	3.75	29000
DSH-22	22	21.0		1.30	0.50	1.20		20.5		4.2	2.8	2.0	1.500	1.5	16.90	5.6	1.5	3.80	
DSH-23	23	22.0	-0.21	1.30	0.50	1.20	-0.06	21.5	+0.21	4.3	2.9	2.0	1.630	1.5	16.60	5.9	1.5	3.80	25000
DSH-24	24	22.9		1.30	0.55	1.20		22.2		4.4	3.0	2.0	1.770	1.7	16.10	6.7	1.5	3.65	
DSH-25	25	23.9	-0.21	1.30	0.55	1.20	-0.06	23.2	-0.42	4.4	3.0	2.0	1.900	1.7	16.20	7.0	1.5	3.70	25000
DSH-26	26	24.9		1.30	0.55	1.20		24.2		4.5	3.1	2.0	1.960	1.7	16.10	7.3	1.5	3.70	
DSH-27	27	25.6	-0.25	1.30	0.70	1.20	-0.06	24.9	+0.25	4.6	3.1	2.0	2.080	2.1	16.40	9.6	1.5	3.80	22500
DSH-28	28	26.6		1.60	0.70	1.50		25.9		4.7	3.2	2.0	2.920	2.1	32.10	10.0	1.5	7.50	
DSH-29	29	27.6	-0.25	1.60	0.70	1.50	-0.06	26.9	-0.50	4.8	3.4	2.0	3.200	2.1	31.80	10.3	1.5	7.45	20000
DSH-30	30	28.6		1.60	0.70	1.50		27.9		5.0	3.5	2.0	3.320	2.1	32.10	10.7	1.5	7.65	
DSH-31	31	29.3	-0.25	1.60	0.85	1.50	-0.06	28.6	+0.25	5.1	3.5	2.5	3.450	2.6	31.50	13.4	2.0	5.60	17900
DSH-32	32	30.3		1.60	0.85	1.50		29.6		5.2	3.6	2.5	3.540	2.6	31.20	13.8	2.0	5.55	
DSH-33	33	31.3	-0.25	1.60	0.85	1.50	-0.06	30.5	-0.50	5.2	3.7	2.5	3.690	2.6	31.60	14.3	2.0	5.65	17400
DSH-34	34	32.3		1.60	0.85	1.50		31.5		5.4	3.8	2.5	3.800	2.6	31.30	14.7	2.0	5.60	
DSH-35	35	33.0	-0.25	1.60	1.00	1.50	-0.06	32.2	-0.50	5.6	3.9	2.5	4.000	3.0	30.80	17.8	2.0	5.55	15500

ALL DIMENSIONS IN MILLIMETERS.

*The radius "R" on the load side must not exceed 0.1T.

*** FOR PLATED RINGS, ADD 0.05 TO THE LISTED MAXIMUM THICKNESS. MAXIMUM RING THICKNESS WILL BE A MINIMUM OF 0.005

LESS THAN THE LISTED GROOVE WIDTH (W) MINIMUM.

FOR HARDNESS SPECIFICATIONS, SEE END OF SECTION.

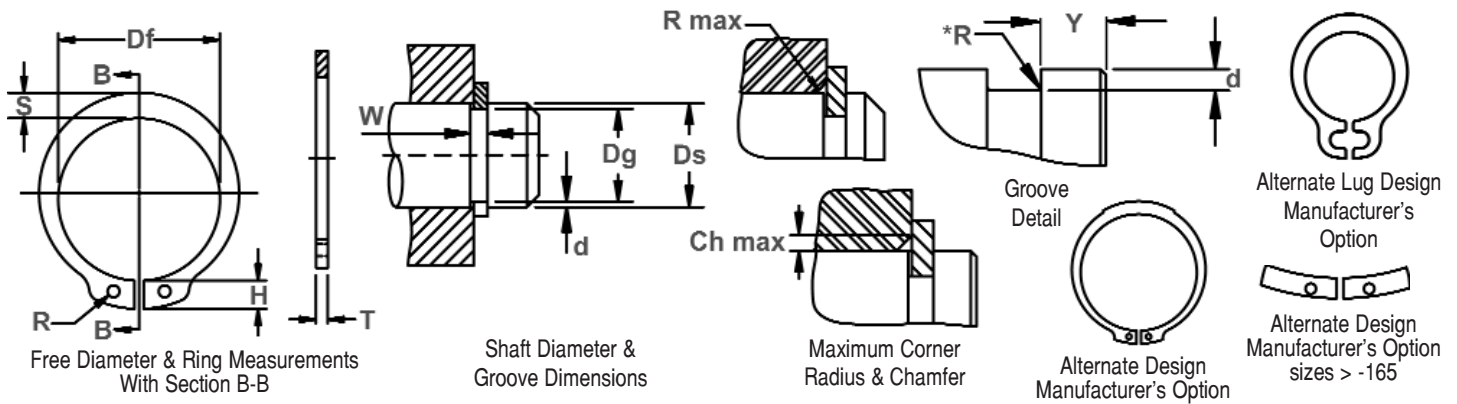

RING NO.	SHAFT DIA. (mm)	GROOVE SIZE					RING SIZE & WEIGHT					SUPPLEMENTARY DATA							
		DIAMETER		WIDTH	DEPTH	THICKNESS ***	FREE DIAMETER		LUG HT.	MAX. SEC.	HOLE DIA.	WEIGHT	EDGE MARGIN	THRUST LOAD Ring	THRUST LOAD Groove	Allowable Rad/ Cham.	Max. Load W/Ch Max.	RPM Limits	
		Ds	Dg	TOL.	W Min.	d	T	Tol.	Df	Tol.	H Max.	S Ref.	R Min.	kg/ 1000	Y Min.	Pr kN	Pg kN	R/Ch Max.	P'r kN
DSH-36	36	34,0	-0,25	1,85	1,00	1,75	-0,06	33,2	+0,25	5,6	4,0	2,5	5,000	3,0	49,40	18,3	2,0	9,00	14500
DSH-37	37	35,0		1,85	1,00	1,75		34,2		5,7	4,1	2,5	5,370	3,0	50,00	18,8	2,0	9,15	14100
DSH-38	38	36,0		1,85	1,00	1,75		35,2		5,8	4,2	2,5	5,620	3,0	49,50	19,3	2,0	9,10	13600
DSH-39	39	37,0		1,85	1,00	1,75		36,0		5,9	4,3	2,5	5,850	3,0	49,80	19,9	2,0	9,25	14500
DSH-40	40	37,5		1,85	1,25	1,75		36,5		6,0	4,4	2,5	6,030	3,8	51,00	25,3	2,0	9,50	14300
DSH-41	41	38,5		1,85	1,25	1,75		37,5		6,2	4,5	2,5	6,215	3,8	50,10	26,0	2,0	9,40	13500
DSH-42	42	39,5		1,85	1,25	1,75		38,5		6,5	4,5	2,5	6,500	3,8	50,00	26,7	2,0	9,45	13000
DSH-44	44	41,5		1,85	1,25	1,75		40,5		6,6	4,6	2,5	7,000	3,8	48,50	28,0	2,0	9,20	11800
DSH-45	45	42,5		1,85	1,25	1,75		41,5		6,7	4,7	2,5	7,500	3,8	49,0	28,6	2,0	9,35	11400
DSH-46	46	43,5		1,85	1,25	1,75		42,5		6,7	4,8	2,5	7,600	3,8	48,9	29,4	2,0	9,40	10900
DSH-47	47	44,5	1,85	1,25	1,75	43,5	6,8	4,9	2,5	7,500	3,8	49,5	30,0	2,0	9,55	11000			
DSH-48	48	45,5	1,85	1,25	1,75	44,5	6,9	5,0	2,5	7,900	3,8	49,4	30,7	2,0	9,55	10000			
DSH-50	50	47,0	2,15	1,50	2,00	45,8	6,9	5,1	2,5	10,20	4,5	73,3	38,0	2,0	14,40	11000			
DSH-52	52	49,0	2,15	1,50	2,00	47,8	7,0	5,2	2,5	11,10	4,5	73,1	39,7	2,5	11,50	10000			
DSH-54	54	51,0	2,15	1,50	2,00	49,8	7,1	5,3	2,5	11,30	4,5	71,2	41,2	2,5	11,30	9000			
DSH-55	55	52,0	2,15	1,50	2,00	50,8	7,2	5,4	2,5	11,40	4,5	71,4	42,0	2,5	11,40	9000			
DSH-56	56	53,0	2,15	1,50	2,00	51,8	7,3	5,5	2,5	11,80	4,5	70,8	42,8	2,5	11,30	9000			
DSH-57	57	54,0	2,15	1,50	2,00	52,8	7,3	5,5	2,5	12,20	4,5	70,9	43,7	2,5	11,40	8000			
DSH-58	58	55,0	2,15	1,50	2,00	53,8	7,3	5,6	2,5	12,60	4,5	71,1	44,3	2,5	11,50	8000			
DSH-60	60	57,0	2,15	1,50	2,00	55,8	7,4	5,8	2,5	12,90	4,5	69,2	46,0	2,5	11,30	8000			
DSH-62	62	59,0	2,15	1,50	2,00	57,8	7,5	6,0	2,5	14,30	4,5	69,3	47,5	2,5	11,40	7000			
DSH-63	63	60,0	2,15	1,50	2,00	58,8	7,6	6,2	2,5	15,90	4,5	70,2	48,3	2,5	11,60	7000			
DSH-65	65	62,0	2,65	1,50	2,50	60,8	7,8	6,3	3,0	18,20	4,5	135,0	49,8	2,5	22,70	7000			
DSH-67	67	64,0	2,65	1,50	2,50	62,5	7,9	6,4	3,0	20,30	4,5	136,0	51,3	2,5	23,00	7000			
DSH-68	68	65,0	2,65	1,50	2,50	63,5	8,0	6,5	3,0	21,80	4,5	135,0	52,2	2,5	23,10	7000			
DSH-70	70	67,0	2,65	1,50	2,50	65,5	8,1	6,6	3,0	22,00	4,5	134,0	53,8	2,5	23,00	7000			
DSH-72	72	69,0	2,65	1,50	2,50	67,5	8,2	6,8	3,0	22,50	4,5	131,0	55,3	2,5	22,80	6000			
DSH-75	75	72,0	2,65	1,50	2,50	70,5	8,4	7,0	3,0	24,60	4,5	130,0	57,6	2,5	22,80	6000			
DSH-77	77	74,0	2,65	1,50	2,50	72,5	8,5	7,2	3,0	25,70	4,5	131,0	59,3	3,0	19,70	6000			
DSH-78	78	75,0	2,65	1,50	2,50	73,5	8,6	7,3	3,0	26,20	4,5	131,0	60,0	3,0	19,70	5000			
DSH-80	80	76,5	2,65	1,75	2,50	74,5	8,6	7,4	3,0	27,30	5,3	128,0	71,6	3,0	19,50	6000			
DSH-82	82	78,5	2,65	1,75	2,50	76,5	8,7	8,7	3,0	31,20	5,3	128,0	73,5	3,0	19,60	6000			
DSH-85	85	81,5	-0,35	3,15	1,75	3,00	-0,08	79,5	8,7	7,8	3,5	36,40	5,3	215,0	76,2	3,0	33,40	6000	

ALL DIMENSIONS IN MILLIMETERS.

*The radius "R" on the load side must not exceed 0.1T.

*** FOR PLATED RINGS, ADD 0.05 TO THE LISTED MAXIMUM THICKNESS. MAXIMUM RING THICKNESS WILL BE A MINIMUM OF 0.005 LESS THAN THE LISTED GROOVE WIDTH (W) MINIMUM. FOR HARDNESS SPECIFICATIONS, SEE END OF SECTION.



DSH Shaft Rings

(DIN 471)

Axially Assembled, External, Metric

Once installed in the groove of a shaft, the portion of the ring protruding from the groove (also called a "shoulder") holds an assembly in place.

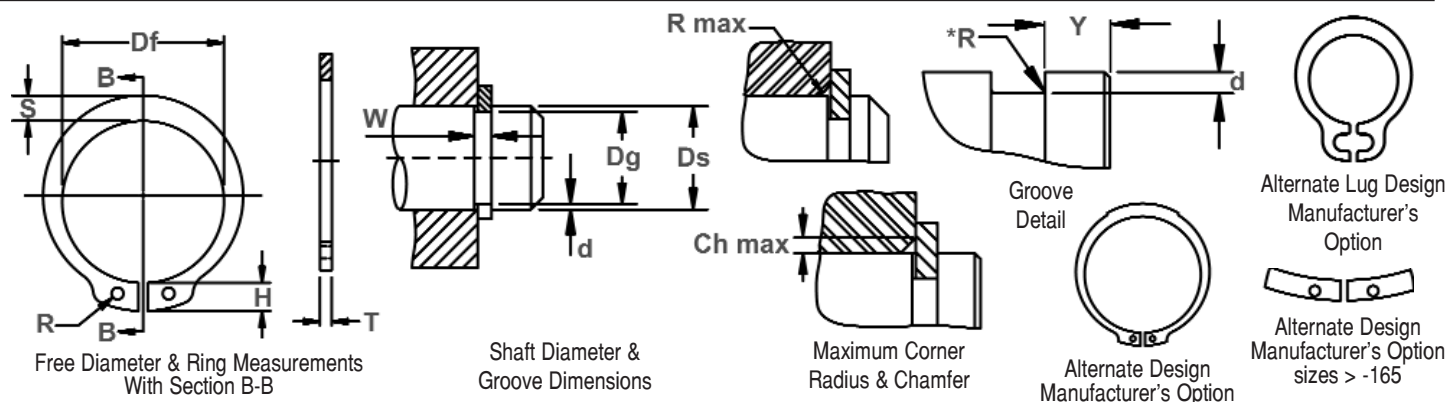

RING NO.	SHAFT DIA. (mm)	GROOVE SIZE					RING SIZE & WEIGHT					SUPPLEMENTARY DATA							
		DIAMETER		WIDTH	DEPTH	THICKNESS ***	FREE DIAMETER		LUG HT.	MAX. SEC.	HOLE DIA.	WEIGHT	EDGE MARGIN	THRUST LOAD Ring	THRUST LOAD Groove	Allowable Rad/Cham.	Max. Load w/Ch Max.	RPM Limits	
		Ds	Dg	TOL.	W Min.	d	T	Tol.	Df	Tol.	H Max.	S Ref.	R Min.	kg/1000	Y Min.	Pr kN	Pg kN	R/Ch Max.	P'r kN
DSH-87	87	83.5	-0.35	3.15	1.75	3.00	-0.08	81.5	+0.54	8.8	7.9	3.5	39.80	5.3	222.0	78.2	3.0	34.80	5000
DSH-88	88	84.5		3.15	1.75	3.00		82.5		8.8	8.0	3.5	41.20	5.3	221.0	79.0	3.0	34.80	5000
DSH-90	90	86.5		3.15	1.75	3.00		84.5		8.8	8.2	3.5	44.50	5.3	217.0	80.0	3.0	34.40	5000
DSH-92	92	88.5		3.15	1.75	3.00		86.5		9.0	8.4	3.5	46.00	5.3	217.0	82.0	3.5	29.60	5000
DSH-95	95	91.5		3.15	1.75	3.00		89.5		9.4	8.6	3.5	49.00	5.3	212.0	85.0	3.5	29.20	5000
DSH-97	97	93.5		3.15	1.75	3.00		91.5		9.4	8.8	3.5	50.20	5.3	211.0	87.0	3.5	29.40	4000
DSH-97	98	94.5	-0.54	3.15	1.75	3.00	-0.10	91.5	+0.63	9.4	8.8	3.5	50.20	5.3	208.0	88.0	3.5	29.00	4000
DSH-100	100	96.5		3.15	1.75	3.00		94.5		9.6	9.0	3.5	53.70	5.3	206.0	90.0	3.5	29.00	4000
DSH-102	102	98.0		4.15	2.00	4.00		95.0		9.7	9.2	3.5	78.00	6.0	482.0	104.0	3.5	68.50	5000
DSH-105	105	101.0		4.15	2.00	4.00		98.0		9.9	9.9	3.5	80.00	6.0	471.0	107.0	3.5	67.70	5000
DSH-107	107	103.0		4.15	2.00	4.00		100.0		10.0	9.5	3.5	81.00	6.0	465.0	110.0	3.5	67.30	5000
DSH-107	108	104.0		4.15	2.00	4.00		100.0		10.0	9.5	3.5	81.00	6.0	459.0	111.0	3.5	66.30	4000
DSH-110	110	106.0	-0.63	4.15	2.00	4.00	-1.50	103.0	+0.63	10.1	9.6	3.5	82.00	6.0	457.0	113.0	3.5	66.90	4000
DSH-112	112	108.0		4.15	2.00	4.00		105.0		10.3	9.7	3.5	83.00	6.0	451.0	115.0	3.5	66.60	4000
DSH-115	115	111.0		4.15	2.00	4.00		108.0		10.6	9.8	3.5	84.00	6.0	438.0	118.0	3.5	65.50	4000
DSH-117	117	113.0		4.15	2.00	4.00		110.0		10.8	10.0	3.5	85.00	6.0	437.0	120.0	3.5	65.60	4000
DSH-117	118	114.0		4.15	2.00	4.00		110.0		10.8	10.0	3.5	85.00	6.0	430.0	121.0	3.5	64.80	4000
DSH-120	120	116.0		4.15	2.00	4.00		113.0		11.0	10.2	3.5	86.00	6.0	424.0	123.0	3.5	64.50	4000
DSH-122	122	118.0	-0.63	4.15	2.00	4.00	-1.50	115.0	+0.63	11.2	10.3	4.0	88.00	6.0	418.0	125.0	4.0	56.60	4000
DSH-125	125	121.0		4.15	2.00	4.00		118.0		11.4	10.4	4.0	90.00	6.0	411.0	128.0	4.0	56.50	3000
DSH-127	127	123.0		4.15	2.00	4.00		120.0		11.4	10.5	4.0	95.00	6.0	407.0	130.0	4.0	56.10	3000
DSH-127	128	124.0		4.15	2.00	4.00		120.0		11.4	10.5	4.0	95.00	6.0	401.0	131.0	4.0	55.60	3000
DSH-130	130	126.0		4.15	2.00	4.00		123.0		11.6	10.7	4.0	100.0	6.0	395.0	134.0	4.0	55.20	3000
DSH-132	132	128.0		4.15	2.00	4.00		125.0		11.7	10.8	4.0	103.0	6.0	396.0	136.0	4.0	55.60	3000
DSH-135	135	131.0	-0.63	4.15	2.00	4.00	-1.50	128.0	+0.63	11.8	11.0	4.0	104.0	6.0	389.0	139.0	4.0	55.40	3000
DSH-137	137	133.0		4.15	2.00	4.00		130.0		11.9	11.0	4.0	107.0	6.0	380.0	141.0	4.0	54.40	3000
DSH-137	138	134.0		4.15	2.00	4.00		130.0		11.9	11.0	4.0	107.0	6.0	381.0	142.0	4.0	54.70	3000
DSH-140	140	136.0		4.15	2.00	4.00		133.0		12.0	11.2	4.0	110.0	6.0	376.0	144.0	4.0	54.40	3000
DSH-142	142	138.0		4.15	2.00	4.00		135.0		12.1	11.3	4.0	112.0	6.0	370.0	146.0	4.0	54.00	3000
DSH-145	145	141.0		4.15	2.00	4.00		138.0		12.2	11.5	4.0	115.0	6.0	367.0	149.0	4.0	53.80	3000
DSH-147	147	143.0	-0.63	4.15	2.00	4.00	-1.50	140.0	+0.63	12.3	11.6	4.0	116.0	6.0	361.0	151.0	4.0	53.50	3000
DSH-147	148	144.0		4.15	2.00	4.00		140.0		12.3	11.6	4.0	116.0	6.0	357.0	152.0	4.0	53.00	2000
DSH-150	150	145.0		4.15	2.50	4.00		142.0		13.0	11.8	4.0	120.0	7.5	357.0	193.0	4.0	53.40	2000

ALL DIMENSIONS IN MILLIMETERS.

*The radius "R" on the load side must not exceed 0.1T.

*** FOR PLATED RINGS, ADD 0.05 TO THE LISTED MAXIMUM THICKNESS. MAXIMUM RING THICKNESS WILL BE A MINIMUM OF 0.005

LESS THAN THE LISTED GROOVE WIDTH (W) MINIMUM.

FOR HARDNESS SPECIFICATIONS, SEE END OF SECTION.

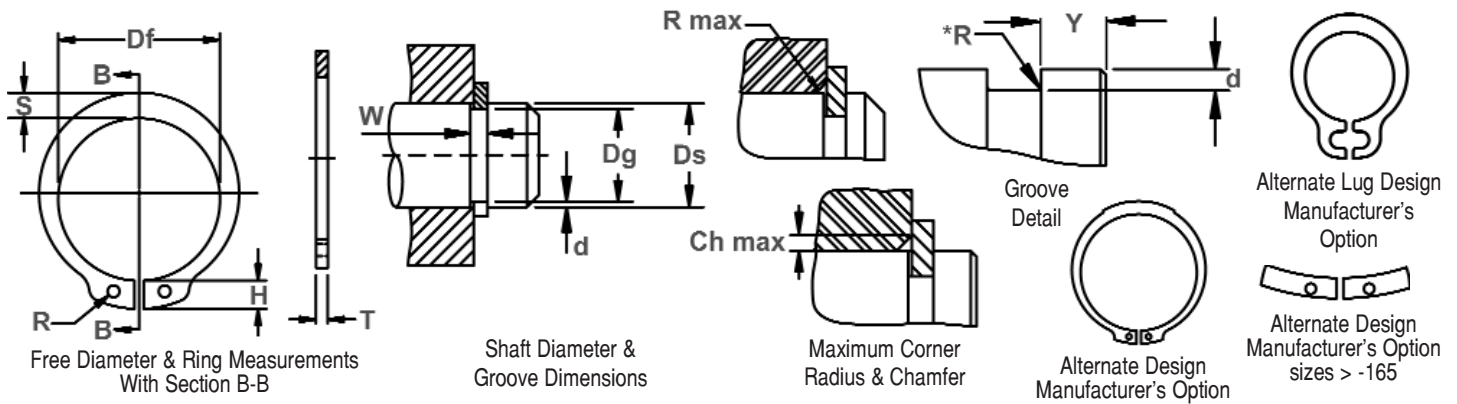

RING NO.	SHAFT DIA. (mm)	GROOVE SIZE			RING SIZE & WEIGHT						SUPPLEMENTARY DATA								
		DIAMETER		DEPTH	THICKNESS ***		FREE DIAMETER		LUG HT.	MAX. SEC.	HOLE DIA.	WEIGHT	EDGE MARGIN	THRUST LOAD Ring	THRUST LOAD Groove	Allowable Rad/Cham.	Max. Load w/Ch Max.	RPM Limits	
		Ds	Dg	TOL.	W Min.	d	T	Tol.	Df	Tol.	H Max.	S Ref.	R Min.	kg/1000	Y Min.	Pr kN	Pg kN	R/Ch Max.	P'r kN
DSH-152	152	147.0		4.15	2.50	4.00		143.0		13.0	11.9	4.0	128.0	7.5	356.0	195.0	4.0	53.10	3000
DSH-155	155	150.0		4.15	2.50	4.00		146.0		13.0	12.0	4.0	135.0	7.5	352.0	199.0	4.0	52.60	3000
DSH-157	157	152.0		4.15	2.50	4.00		148.0		13.1	12.0	4.0	140.0	7.5	352.0	202.0	4.0	52.50	3000
DSH-157	158	153.0		4.15	2.50	4.00		148.0		13.1	12.0	4.0	140.0	7.5	353.0	203.0	4.0	52.70	3000
DSH-160	160	155.0		4.15	2.50	4.00		151.0		13.3	12.2	4.0	150.0	7.5	349.0	206.0	4.0	52.20	3000
DSH-162	162	157.0		4.15	2.50	4.00		152.5		13.3	12.3	4.0	155.0	7.5	348.0	208.0	5.0	41.70	3000
DSH-165	165	160.0		4.15	2.50	4.00		155.5		13.5	12.5	4.0	160.0	7.5	345.0	212.0	5.0	41.40	3000
DSH-167	167	162.0		4.15	2.50	4.00		157.5		13.5	12.9	4.0	163.0	7.5	354.0	215.0	5.0	42.50	3000
DSH-167	168	163.0	-0.63	4.15	2.50	4.00	-0.10	157.5	+0.63	13.5	12.9	4.0	163.0	7.5	353.0	216.0	5.0	42.40	2000
DSH-170	170	165.0		4.15	2.50	4.00		160.5	-1.50	13.5	12.9	4.0	170.0	7.5	349.0	219.0	5.0	41.90	2000
DSH-170	172	167.0		4.15	2.50	4.00		160.5		13.5	12.9	4.0	170.0	7.5	344.0	221.0	5.0	41.30	2000
DSH-175	175	170.0		4.15	2.50	4.00		165.5		13.5	12.9	4.0	180.0	7.5	340.0	225.0	5.0	40.70	2000
DSH-177	177	172.0		4.15	2.50	4.00		167.5		14.2	13.5	4.0	183.0	7.5	335.0	228.0	5.0	40.20	2000
DSH-177	178	173.0		4.15	2.50	4.00		167.5		14.2	13.5	4.0	183.0	7.5	349.0	229.0	5.0	42.00	2000
DSH-180	180	175.0		4.15	2.50	4.00		170.5		14.2	13.5	4.0	190.0	7.5	345.0	232.0	5.0	41.40	2000
DSH-180	182	177.0		4.15	2.50	4.00		170.5		14.2	13.5	4.0	190.0	7.5	341.0	235.0	5.0	41.00	2000
DSH-185	185	180.0		4.15	2.50	4.00		175.5		14.2	13.5	4.0	200.0	7.5	336.0	238.0	5.0	40.40	2000
DSH-187	187	182.0		4.15	2.50	4.00		177.5		14.2	14.0	4.0	203.0	7.5	338.0	241.0	5.0	40.50	2000
DSH-187	188	183.0		4.15	2.50	4.00		177.5		14.2	14.0	4.0	203.0	7.5	337.0	242.0	5.0	40.60	2000
DSH-190	190	185.0		4.15	2.50	4.00		180.5		14.2	14.0	4.0	210.0	7.5	333.0	245.0	5.0	40.00	2000
DSH-190	192	187.0		4.15	2.50	4.00		180.5		14.2	14.0	4.0	210.0	7.5	330.0	248.0	5.0	39.60	2000
DSH-195	195	190.0		4.15	2.50	4.00		185.5		14.2	14.0	4.0	220.0	7.5	325.0	251.0	5.0	39.00	2000
DSH-197	197	192.0		4.15	2.50	4.00		187.5		14.2	14.0	4.0	223.0	7.5	322.0	254.0	5.0	38.60	2000
DSH-197	198	193.0		4.15	2.50	4.00		187.5		14.2	14.0	4.0	223.0	7.5	322.0	255.0	5.0	38.70	2000
DSH-200	200	195.0		4.15	2.50	4.00		190.5	+0.72	14.2	14.0	4.0	230.0	7.5	319.0	258.0	5.0	38.30	2000
DSH-202	202	196.0	-0.72	5.15	3.00	5.00		190.0	-1.70	14.2	14.0	4.0	235.0	9.0	624.0	312.0	6.0	62.50	2000
DSH-205	205	199.0		5.15	3.00	5.00		193.0		14.2	14.0	4.0	243.0	9.0	611.0	317.0	6.0	61.30	2000
DSH-205	207	201.0		5.15	3.00	5.00		193.0		14.2	14.0	4.0	243.0	9.0	608.0	320.0	6.0	60.90	2000
DSH-205	208	202.0		5.15	3.00	5.00		193.0		14.2	14.0	4.0	243.0	9.0	605.0	321.0	6.0	60.50	2000
DSH-210	210	204.0		5.15	3.00	5.00		198.0		14.2	14.0	4.0	248.0	9.0	598.0	325.0	6.0	59.90	2000
DSH-210	212	206.0		5.15	3.00	5.00		198.0		14.2	14.0	4.0	248.0	9.0	593.0	328.0	6.0	59.50	2000
DSH-215	215	209.0		5.15	3.00	5.00		203.0		14.2	14.0	4.0	260.0	9.0	585.0	332.0	6.0	58.50	2000
DSH-215	217	211.0		5.15	3.00	5.00		203.0		14.2	14.0	4.0	260.0	9.0	580.0	336.0	6.0	58.10	2000
DSH-215	218	212.0		5.15	3.00	5.00		203.0		14.2	14.0	4.0	260.0	9.0	577.0	337.0	6.0	57.80	2000

ALL DIMENSIONS IN MILLIMETERS.

*The radius "R" on the load side must not exceed 0.1T.

*** FOR PLATED RINGS, ADD 0.05 TO THE LISTED MAXIMUM THICKNESS. MAXIMUM RING THICKNESS WILL BE A MINIMUM OF 0.005 LESS THAN THE LISTED GROOVE WIDTH (W) MINIMUM. FOR HARDNESS SPECIFICATIONS, SEE END OF SECTION.





DSH Shaft Rings

(DIN 471)

Axially Assembled, External, Metric

Once installed in the groove of a shaft, the portion of the ring protruding from the groove (also called a "shoulder") holds an assembly in place.

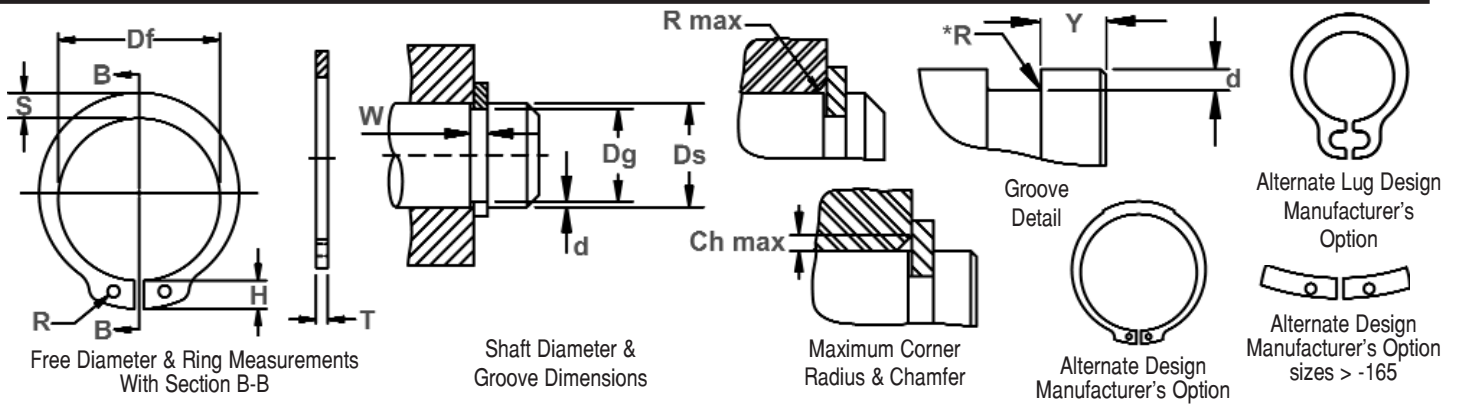

RING NO.	SHAFT DIA. (mm)	GROOVE SIZE					RING SIZE & WEIGHT						SUPPLEMENTARY DATA							
		DIAMETER		WIDTH	DEPTH		THICKNESS ***		FREE DIAMETER		LUG HT.	MAX. SEC.	HOLE DIA.	WEIGHT	EDGE MARGIN	THRUST LOAD Ring	THRUST LOAD Groove	Allowable Rad/Cham.	Max. Load w/Ch Max.	RPM Limits
		Ds	Dg	TOL.	W Min.	d	T	Tol.	Df	Tol.	H Max.	S Ref.	R Min.	kg/1000	Y Min.	Pr kN	Pg kN	R/Ch Max.	P'r kN	
DSH-220	220	214.0		5,15	3,00	5,00		208,0		14,2	14,0	4,0	265,0	9,0	572,0	340,0	6,0	57,30	2000	
DSH-220	222	216,0		5,15	3,00	5,00		208,0		14,2	14,0	4,0	265,0	9,0	567,0	343,0	6,0	56,80	2000	
DSH-225	225	219,0		5,15	3,00	5,00		213,0		14,2	14,0	4,0	280,0	9,0	559,0	349,0	6,0	56,00	2000	
DSH-225	227	221,0		5,15	3,00	5,00		213,0		14,2	14,0	4,0	280,0	9,0	555,0	351,0	6,0	55,50	1000	
DSH-225	228	222,0		5,15	3,00	5,00		213,0		14,2	14,0	4,0	280,0	9,0	552,0	353,0	6,0	55,40	1000	
DSH-230	230	224,0		5,15	3,00	5,00		218,0		14,2	14,0	4,0	290,0	9,0	548,0	356,0	6,0	55,00	1000	
DSH-230	232	226,0		5,15	3,00	5,00		218,0		14,2	14,0	4,0	290,0	9,0	543,0	359,0	6,0	54,50	1000	
DSH-235	235	229,0		5,15	3,00	5,00		223,0		14,2	14,0	4,0	305,0	9,0	537,0	364,0	6,0	53,80	1000	
DSH-235	237	231,0	-0,72	5,15	3,00	5,00	-0,12	223,0	+0,72	14,2	14,0	4,0	305,0	9,0	532,0	367,0	6,0	53,40	1000	
DSH-235	238	232,0		5,15	3,00	5,00		223,0	-1,70	14,2	14,0	4,0	305,0	9,0	530,0	369,0	6,0	53,00	1000	
DSH-240	240	234,0		5,15	3,00	5,00		228,0		14,2	14,0	4,0	310,0	9,0	530,0	372,0	6,0	53,00	1000	
DSH-240	242	236,0		5,15	3,00	5,00		228,0		14,2	14,0	4,0	310,0	9,0	520,0	375,0	6,0	52,20	1000	
DSH-245	245	239,0		5,15	3,00	5,00		233,0		14,2	14,0	4,0	325,0	9,0	515,0	380,0	6,0	51,50	1000	
DSH-245	247	241,0		5,15	3,00	5,00		233,0		14,2	14,0	4,0	325,0	9,0	511,0	383,0	6,0	51,20	1000	
DSH-245	248	242,0		5,15	3,00	5,00		233,0		14,2	14,0	4,0	325,0	9,0	508,0	385,0	6,0	50,90	1000	
DSH-250	250	244,0		5,15	3,00	5,00		238,0		14,2	14,0	4,0	335,0	9,0	504,0	388,0	6,0	50,50	1000	
DSH-250	252	244,0		5,15	4,00	5,00		238,0		16,2	16,0	5,0	335,0	12,0	563,0	519,0	6,0	56,40	1000	
DSH-255	255	247,0		5,15	4,00	5,00		240,0		16,2	16,0	5,0	348,0	12,0	557,0	525,0	6,0	55,70	1000	
DSH-255	257	249,0		5,15	4,00	5,00		240,0		16,2	16,0	5,0	348,0	12,0	551,0	529,0	6,0	55,20	1000	
DSH-255	258	250,0		5,15	4,00	5,00		240,0		16,2	16,0	5,0	348,0	12,0	550,0	531,0	6,0	55,10	1000	
DSH-260	260	252,0	-0,81	5,15	4,00	5,00		245,0		16,2	16,0	5,0	355,0	12,0	540,0	535,0	6,0	54,60	1000	
DSH-260	262	254,0		5,15	4,00	5,00		245,0		16,2	16,0	5,0	355,0	12,0	542,0	540,0	6,0	54,40	1000	

ALL DIMENSIONS IN MILLIMETERS.

*The radius "R" on the load side must not exceed 0.1T.

*** FOR PLATED RINGS, ADD 0.05 TO THE LISTED MAXIMUM THICKNESS. MAXIMUM RING THICKNESS WILL BE A MINIMUM OF 0.005

LESS THAN THE LISTED GROOVE WIDTH (W) MINIMUM.
FOR HARDNESS SPECIFICATIONS, SEE END OF SECTION.

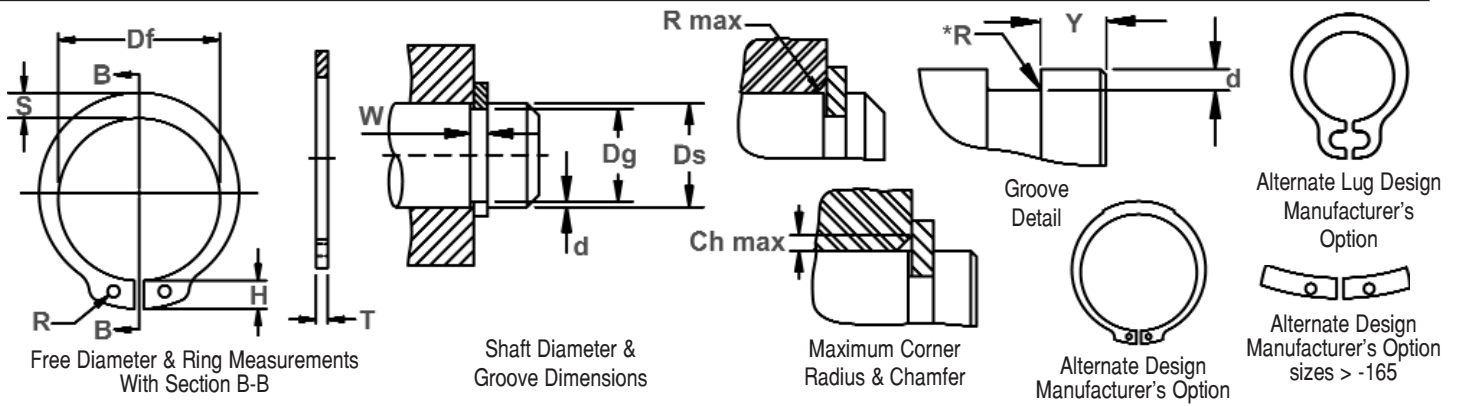

RING NO.	SHAFT DIA. (mm)	GROOVE SIZE			RING SIZE & WEIGHT						SUPPLEMENTARY DATA								
		DIAMETER		WIDTH	DEPTH	THICKNESS ***		FREE DIAMETER	LUG HT.	MAX. SEC.	HOLE DIA.	WEIGHT	EDGE MARGIN	THRUST LOAD Ring	THRUST LOAD Groove	Allowable Rad/Cham.	Max. Load w/Ch Max.	RPM Limits	
		Ds	Dg	TOL.	W Min.	d	T	Tol.	Df	Tol.	H Max.	S Ref.	R Min.	kg/1000	Y Min.	Pr kN	Pg kN		R/Ch Max.
DSH-265	265	257.0		5,15	4,00	5,00		250,0	+0,72	16,2	16,0	5,0	370,0	12,0	536,0	546,0	6,0	53,70	1000
DSH-265	267	259,0		5,15	4,00	5,00		250,0	-1,70	16,2	16,0	5,0	370,0	12,0	532,0	550,0	6,0	53,30	1000
DSH-265	268	260,0		5,15	4,00	5,00		250,0		16,2	16,0	5,0	370,0	12,0	529,0	553,0	6,0	53,00	1000
DSH-270	270	262,0		5,15	4,00	5,00		255,0		16,2	16,0	5,0	375,0	12,0	525,0	556,0	6,0	52,50	1000
DSH-270	272	264,0		5,15	4,00	5,00		255,0		16,2	16,0	5,0	375,0	12,0	522,0	560,0	6,0	52,00	1000
DSH-275	275	267,0		5,15	4,00	5,00		260,0		16,2	16,0	5,0	390,0	12,0	516,0	566,0	6,0	51,00	1000
DSH-275	277	269,0		5,15	4,00	5,00		260,0		16,2	16,0	5,0	390,0	12,0	513,0	571,0	6,0	51,00	1000
DSH-275	278	270,0		5,15	4,00	5,00		260,0		16,2	16,0	5,0	390,0	12,0	510,0	574,0	6,0	51,00	1000
DSH-280	280	272,0		5,15	4,00	5,00		265,0		16,2	16,0	5,0	398,0	12,0	508,0	576,0	6,0	50,00	1000
DSH-280	282	274,0	-0,81	5,15	4,00	5,00	-0,12	265,0		16,2	16,0	5,0	398,0	12,0	503,0	580,0	6,0	50,00	1000
DSH-285	285	277,0		5,15	4,00	5,00		270,0	+0,81	16,2	16,0	5,0	410,0	12,0	499,0	587,0	6,0	50,00	1000
DSH-285	287	279,0		5,15	4,00	5,00		270,0	-2,00	16,2	16,0	5,0	410,0	12,0	494,0	591,0	6,0	49,00	1000
DSH-285	288	280,0		5,15	4,00	5,00		270,0		16,2	16,0	5,0	410,0	12,0	493,0	594,0	6,0	49,00	1000
DSH-290	290	282,0		5,15	4,00	5,00		275,0		16,2	16,0	5,0	418,0	12,0	490,0	599,0	6,0	49,00	1000
DSH-290	292	284,0		5,15	4,00	5,00		275,0		16,2	16,0	5,0	418,0	12,0	487,0	603,0	6,0	48,00	1000
DSH-295	295	287,0		5,15	4,00	5,00		280,0		16,2	16,0	5,0	430,0	12,0	481,0	609,0	6,0	48,00	1000
DSH-295	297	289,0		5,15	4,00	5,00		280,0		16,2	16,0	5,0	430,0	12,0	479,0	613,0	6,0	48,00	1000
DSH-295	298	290,0		5,15	4,00	5,00		280,0		16,2	16,0	5,0	430,0	12,0	476,0	615,0	6,0	47,00	1000
DSH-300	300	292,0		5,15	4,00	5,00		285,0		16,2	16,0	5,0	440,0	12,0	475,0	619,0	6,0	47,00	1000
DSH-305	305	295,0		6,20	5,00	6,00		288,0		20,2	20,0	6,0	738,0	15,0	1036,0	785,0	7,0	89,00	1000
DSH-310	310	300,0		6,20	5,00	6,00	-0,15	293,0		20,2	20,0	6,0	750,0	15,0	1016,0	796,0	7,0	87,00	1000
DSH-315	315	305,0		6,20	5,00	6,00		298,0		20,2	20,0	6,0	760,0	15,0	1007,0	811,0	7,0	86,00	1000

ALL DIMENSIONS IN MILLIMETERS.

*The radius "R" on the load side must not exceed 0.1T.

*** FOR PLATED RINGS, ADD 0.05 TO THE LISTED MAXIMUM THICKNESS. MAXIMUM RING THICKNESS WILL BE A MINIMUM OF 0.005

LESS THAN THE LISTED GROOVE WIDTH (W) MINIMUM.

FOR HARDNESS SPECIFICATIONS, SEE END OF SECTION.



DSH Shaft Rings

(DIN 471)

Axially Assembled, External, Metric

Once installed in the groove of a shaft, the portion of the ring protruding from the groove (also called a "shoulder") holds an assembly in place.

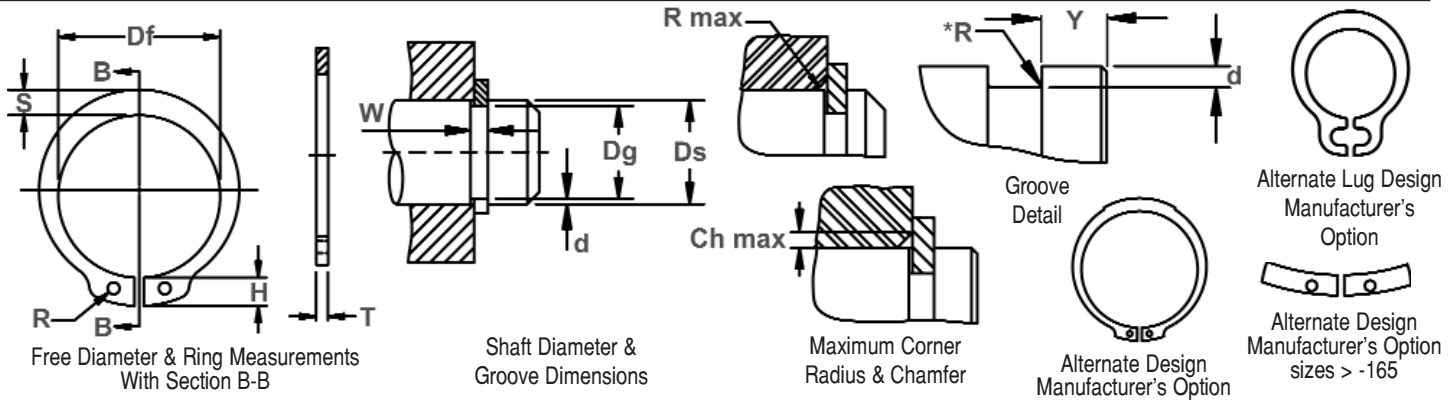

RING NO.	SHAFT DIA. (mm)	GROOVE SIZE					RING SIZE & WEIGHT					SUPPLEMENTARY DATA								
		DIAMETER		WIDT	DEPTH		THICKNESS ***		FREE DIAMETER		LUG HT.	MAX. SEC.	HOLE DIA.	WEIGHT	EDGE MARGIN	THRUST LOAD Ring	THRUST LOAD Groove	Allowable Rad/Cham.	Max. Load w/Ch Max.	RPM Limits
		Ds	Dg	TOL.	W Min.	d	T	Tol.	Df	Tol.	H Max.	S Ref.	R Min.	kg/1000	Y Min.	Pr kN	Pg kN	R/Ch Max.	Pr kN	
DSH-320	320	310,0	-0,81	6,20	5,00	6,00		303,0	+0,81	20,2	20,0	6,0	770,0	15,0	988,0	825,0	7,0	85,00	1000	
DSH-325	325	315,0		6,20	5,00	6,00		308,0	-2,00	20,2	20,0	6,0	787,0	15,0	975,0	837,0	7,0	83,00	1000	
DSH-330	330	320,0		6,20	5,00	6,00		313,0		20,2	20,0	6,0	800,0	15,0	958,0	850,0	7,0	82,00	1000	
DSH-335	335	325,0		6,20	5,00	6,00		318,0		20,2	20,0	6,0	826,0	15,0	945,0	864,0	7,0	81,00	1000	
DSH-340	340	330,0		6,20	5,00	6,00		323,0		20,2	20,0	6,0	840,0	15,0	932,0	876,0	7,0	80,00	1000	
DSH-345	345	335,0		6,20	5,00	6,00		328,0		20,2	20,0	6,0	845,0	15,0	917,0	890,0	7,0	79,00	1000	
DSH-350	350	340,0		6,20	5,00	6,00		333,0		20,2	20,0	6,0	850,0	15,0	906,0	903,0	7,0	77,00	1000	
DSH-355	355	345,0		6,20	5,00	6,00		338,0		20,2	20,0	6,0	865,0	15,0	894,0	916,0	7,0	76,00	1000	
DSH-360	360	350,0	-0,89	6,20	5,00	6,00	-0,15	343,0	+0,90	20,2	20,0	6,0	880,0	15,0	880,0	928,0	7,0	75,00	1000	
DSH-365	365	355,0		6,20	5,00	6,00		348,0	-2,00	20,2	20,0	6,0	885,0	15,0	868,0	942,0	7,0	74,00	1000	
DSH-370	370	360,0		6,20	5,00	6,00		353,0		20,2	20,0	6,0	890,0	15,0	856,0	955,0	7,0	73,00	1000	
DSH-375	375	365,0		6,20	5,00	6,00		358,0		20,2	20,0	6,0	910,0	15,0	847,0	968,0	7,0	72,00	1000	
DSH-380	380	370,0		6,20	5,00	6,00		363,0		20,2	20,0	6,0	930,0	15,0	833,0	980,0	7,0	71,00	1000	
DSH-385	385	375,0		6,20	5,00	6,00		368,0		20,2	20,0	6,0	940,0	15,0	823,0	994,0	7,0	70,00	1000	
DSH-390	390	380,0		6,20	5,00	6,00		373,0		20,2	20,0	6,0	950,0	15,0	814,0	1008,0	7,0	70,00	1000	
DSH-395	395	385,0		6,20	5,00	6,00		378,0		20,2	20,0	6,0	990,0	15,0	803,0	1021,0	7,0	69,00	1000	
DSH-400	400	390,0		6,20	5,00	6,00		383,0		20,2	20,0	6,0	1040,0	15,0	793,0	1033,0	7,0	69,00	1000	
DSH-410	410	398,0		7,20	6,00	7,00		390,0		26,2	26,0	6,0	1320,0	18,0	1616,0	1269,0	7,0	139,0	1000	
DSH-420	420	408,0	-1,00	7,20	6,00	7,00		400,0	+1,00	26,2	26,0	6,0	1360,0	18,0	1569,0	1300,0	7,0	135,0	1000	
DSH-430	430	418,0		7,20	6,00	7,00		410,0	-2,00	26,2	26,0	6,0	1390,0	18,0	1540,0	1332,0	7,0	132,0	1000	
DSH-440	440	428,0		7,20	6,00	7,00		420,0		26,2	26,0	6,0	1420,0	18,0	1500,0	1363,0	7,0	129,0	1000	
DSH-450	450	438,0		7,20	6,00	7,00		430,0		26,2	26,0	6,0	1450,0	18,0	1472,0	1393,0	7,0	126,0	1000	

ALL DIMENSIONS IN MILLIMETERS.

*The radius "R" on the load side must not exceed 0.1T.

*** FOR PLATED RINGS, ADD 0.05 TO THE LISTED MAXIMUM THICKNESS. MAXIMUM RING THICKNESS WILL BE A MINIMUM OF 0.005 LESS THAN THE LISTED GROOVE WIDTH (W) MINIMUM.

HARDNESS RANGES: STAINLESS STEEL RINGS (DIN 1.4122 X39CrMo17)

RING TYPE	SIZE RANGE	HARDNESS			
		HV	HRC	15N	30N
DSH	ALL	470-580	47-54	84-87.5	66-72

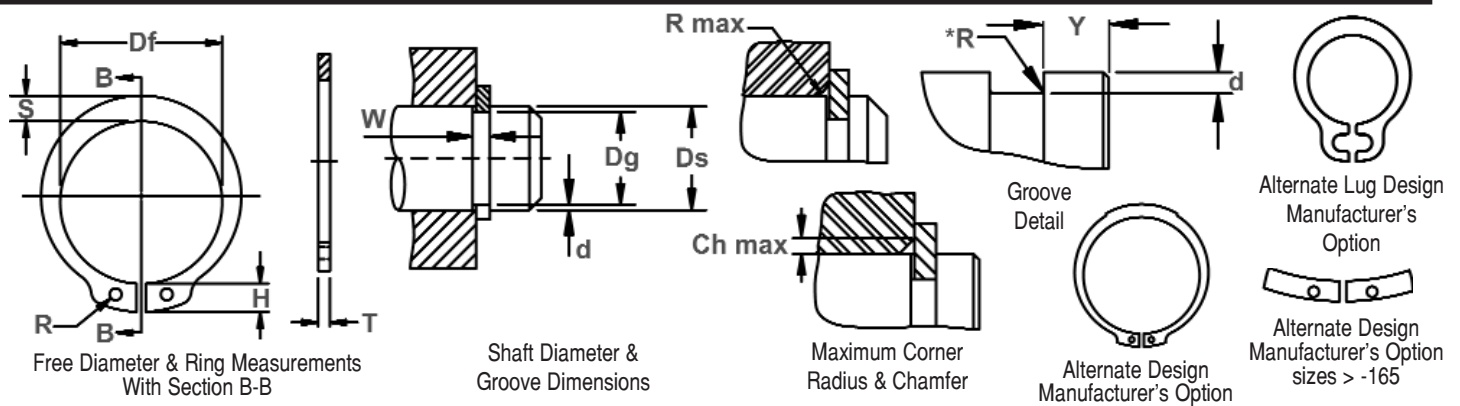

RING NO.	SHAFT DIA. (mm)	GROOVE SIZE			RING SIZE & WEIGHT						SUPPLEMENTARY DATA							
		DIAMETER	WIDT	DEPTH	THICKNESS ***		FREE DIAMETER		LUG HT.	MAX. SEC.	HOLE DIA.	WEIGHT	EDGE MARGIN	THRUST LOAD Ring	THRUST LOAD Groove	Allowable Rad/Cham.	Max. Load w/Ch Max.	RPM Limits
					Ds	Dg	TOL.	W Min.										
DSH-460	460	448.0	7.20	6.00	7.00		440.0		26.2	26.0	6.0	1520.0	18.0	1443.0	1426.0	7.0	124.0	1000
DSH-470	470	458.0	7.20	6.00	7.00		450.0		26.2	26.0	6.0	1590.0	18.0	1413.0	1457.0	7.0	121.0	1000
DSH-480	480	468.0	7.20	6.00	7.00		460.0		26.2	26.0	6.0	1660.0	18.0	1383.0	1489.0	7.0	119.0	500
DSH-490	490	478.0	7.20	6.00	7.00		470.0	+1.00	26.2	26.0	6.0	1725.0	18.0	1355.0	1520.0	7.0	116.0	500
DSH-500	500	488.0	7.20	6.00	7.00		480.0	-2.00	26.2	26.0	6.0	1790.0	18.0	1329.0	1550.0	7.0	114.0	500
DSH-510	510	496.0	8.20	7.00	8.00		485.0		26.2	26.0	6.0	2300.0	21.0	1952.0	1843.0	7.0	167.0	1000
DSH-520	520	506.0	8.20	7.00	8.00	-0.15	495.0		26.2	26.0	6.0	2350.0	21.0	1910.0	1880.0	7.0	164.0	500
DSH-530	530	516.0	8.20	7.00	8.00		505.0		26.2	26.0	6.0	2400.0	21.0	1878.0	1916.0	7.0	161.0	500
DSH-540	540	526.0	8.20	7.00	8.00		515.0		26.2	26.0	6.0	2445.0	21.0	1846.0	1953.0	7.0	158.0	400
DSH-550	550	536.0	8.20	7.00	8.00	-1.00	525.0		26.2	26.0	6.0	2490.0	21.0	1812.0	1986.0	7.0	155.0	400
DSH-560	560	546.0	8.20	7.00	8.00		535.0		26.2	26.0	6.0	2580.0	21.0	1777.0	2026.0	7.0	153.0	400
DSH-570	570	556.0	8.20	7.00	8.00		545.0	+1.50	26.2	26.0	6.0	2670.0	21.0	1750.0	2063.0	7.0	150.0	400
DSH-580	580	566.0	8.20	7.00	8.00		555.0	-3.00	26.2	26.0	6.0	2760.0	21.0	1718.0	2100.0	7.0	147.0	400
DSH-590	590	576.0	8.20	7.00	8.00		565.0		26.2	26.0	6.0	2840.0	21.0	1689.0	2136.0	7.0	145.0	400
DSH-600	600	586.0	8.20	7.00	8.00		575.0		26.2	26.0	6.0	2920.0	21.0	1600.0	2170.0	7.0	143.0	300
DSH-650	650	634.0	9.30	8.00	9.00		620.0		34.0	34.0	6.0	3770.0	24.0	2810.0	2640.0	7.0	242.0	400
DSH-700**	700	684.0	9.30	8.00	9.00		670.0		34.0	34.0	6.0	4070.0	24.0	2615.0	2890.0	7.0	225.0	300
DSH-750**	750	732.0	9.30	9.00	9.00		715.0		34.0	34.0	9.0	4640.0	27.0	2450.0	3490.0	7.0	207.0	190
DSH-800**	800	782.0	9.30	9.00	9.00	-0.2	765.0		34.0	34.0	9.0	5330.0	27.0	2299.0	3730.0	7.0	195.0	300
DSH-850**	850	830.0	9.30	10.00	9.00		810.0		34.0	34.0	9.0	6030.0	30.0	2166.0	4400.0	7.0	183.0	300
DSH-900**	900	880.0	9.30	10.00	9.00		860.0	+2.00	34.0	34.0	9.0	6640.0	30.0	2047.0	4650.0	7.0	173.0	200
DSH-950**	950	928.0	9.30	11.00	9.00		900.0	-4.00	34.0	34.0	9.0	7260.0	33.0	1945.0	5400.0	7.0	165.0	200
DSH-1000**	1000	978.0	9.30	11.00	9.00		950.0		34.0	34.0	9.0	8130.0	33.0	1851.0	5700.0	7.0	157.0	200

ALL DIMENSIONS IN MILLIMETERS.

*The radius "R" on the load side must not exceed 0.1T.

** THESE PARTS ARE MADE WITH A CONSTANT SECTION WIDTH (NO TAPER)

*** FOR PLATED RINGS, ADD 0.05 TO THE LISTED MAXIMUM THICKNESS. MAXIMUM RING THICKNESS WILL BE A MINIMUM OF 0.005 LESS THAN THE LISTED GROOVE WIDTH (W) MINIMUM.

HARDNESS RANGES: STAINLESS STEEL RINGS (PH 15-7MO)

RING TYPE	SIZE RANGE	HARDNESS		
		VICKERS	ROCKWELL	
DSH	3 & 4	435-530	44-51	82.5-86 HR30N**
				63-69.5 HR30N

*WHERE APPLICABLE

** HARDNESS CAN NOT BE CHECKED WITH ANY DEGREE OF ACCURACY DIRECTLY ON THESE RINGS.

HARDNESS RANGES: CARBON STEEL RINGS (SAE 1060-1090)

RING TYPE	SIZE RANGE	HARDNESS		
		VICKERS	ROCKWELL	
DSH	3 & 4	470-580	HRC	LOWER SCALE*
			47-54	84-87.5 HR30N**
			47-54	66-72 HR30N
			47-54	-
			44-51	-
			40-47	-

*WHERE APPLICABLE

**HARDNESS CAN NOT BE CHECKED WITH ANY DEGREE OF ACCURACY DIRECTLY ON THESE RINGS.





DSI Shaft Rings

Axially Assembled, External Inverted, Metric

Functions like a DSH ring in a shaft, only the lugs are "reversed."

This version reduces the distance the lugs of the standard DSH extend beyond the circumference of the shaft. The shaft can then be used in an application where clearance is minimal.

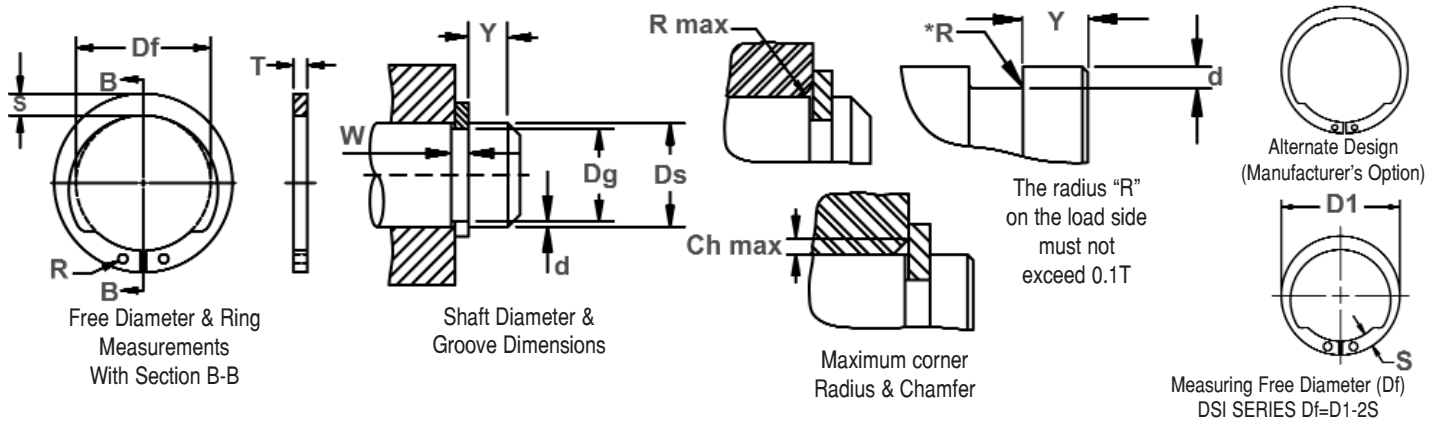

RING NO.	SHAFT DIA.	GROOVE SIZE					RING SIZE & WEIGHT						SUPPLEMENTARY DATA						
		DIAMETER		WIDTH	DEPTH		THICKNESS ***		FREE DIAMETER		MAX. SEC.	HOLE DIA.	WEIGHT	EDGE MARGIN	THRUST LOAD Ring	THRUST LOAD Groove	Allowable Rad/Cham.	Max. load w/R/Ch. Max.	RPM Limits
		Ds	Dg	Tol.	W Min.	d	T	Tol.	Df	Tol.	S	Tol.	R Min.	kg/1000	Y Min.	Pr kN	Pg kN	R/Ch Max.	P'r kN
DSI-12	12	11,5		1,10	0,25	1,00		11,00		2,1		1,3	0,50	0,7	4,5	0,70	1,0	2,4	79000
DSI-13	13	12,4		1,10	0,30	1,00		11,90		2,1		1,3	0,56	0,9	5,5	0,90	1,0	2,4	64000
DSI-14	14	13,4		1,10	0,30	1,00		12,90	+0,10	2,1		1,3	0,58	0,9	6,0	0,97	1,0	2,4	56000
DSI-15	15	14,3	-0,11	1,10	0,35	1,00		13,80	-0,36	2,2		1,3	0,66	1,0	6,5	1,22	1,0	2,4	50000
DSI-16	16	15,2		1,10	0,40	1,00		14,70		2,3		1,3	0,72	1,2	7,0	1,48	1,0	2,5	45000
DSI-17	17	16,2		1,10	0,40	1,00		15,70		2,4		1,3	0,81	1,2	8,1	1,57	1,0	2,6	41000
DSI-18	18	17,0		1,30	0,50	1,20		16,50		2,6		1,5	1,14	1,5	14,8	2,07	1,5	3,2	39000
DSI-20	20	19,0		1,30	0,50	1,20		18,50		2,8		1,5	1,43	1,5	14,6	2,30	1,5	3,1	32000
DSI-21	21	20,0	-0,15	1,30	0,50	1,20		19,35	+0,13	2,8		1,5	1,53	1,5	14,4	2,42	1,5	3,1	29000
DSI-22	22	21,0		1,30	0,50	1,20	-0,06	20,50	-0,42	3,0		1,5	1,63	1,5	14,2	2,53	1,5	3,1	27000
DSI-23	23	22,0		1,30	0,50	1,20		21,50		3,1	±0,1	1,5	1,78	1,5	14,0	2,66	1,5	3,1	25000
DSI-24	24	22,9		1,30	0,55	1,20		22,20		3,2		1,5	1,90	1,6	14,0	3,03	1,5	3,1	27000
DSI-25	25	23,9		1,30	0,55	1,20		23,20		3,4		1,5	2,10	1,6	14,1	3,18	1,5	3,2	25000
DSI-26	26	24,9	-0,21	1,30	0,55	1,20		24,20	+0,21	3,5		1,5	2,18	1,6	14,1	3,30	1,5	3,2	25000
DSI-28	28	26,6		1,60	0,70	1,50		25,90	-0,42	3,8		2,0	3,18	2,1	28,0	4,50	1,5	6,4	22000
DSI-30	30	28,6		1,60	0,70	1,50		27,90		3,9		2,0	3,58	2,1	27,5	4,86	1,5	6,3	19000
DSI-32	32	30,3		1,60	0,85	1,50		29,60		4,0		2,0	3,88	2,5	27,0	6,25	2,0	4,7	17000
DSI-34	34	32,3	-0,25	1,60	0,85	1,50		31,50	+0,25	3,5		2,0	3,60	2,5	26,6	6,67	2,0	4,6	15000
DSI-35	35	33,0		1,60	1,00	1,50		32,20	-0,50	4,2		2,0	4,53	3,0	26,6	8,00	2,0	4,6	16000
DSI-38	38	35,8		1,85	1,10	1,75		34,50		4,5		2,0	5,50	3,3	42,0	10,60	2,0	7,8	15000

*** FOR PLATED RINGS, ADD 0.05 TO THE LISTED MAXIMUM THICKNESS. MAXIMUM RING THICKNESS WILL BE A MINIMUM OF 0.005 LESS THAN THE LISTED GROOVE WIDTH (W) MINIMUM.

ALL DIMENSIONS IN MILLIMETERS.

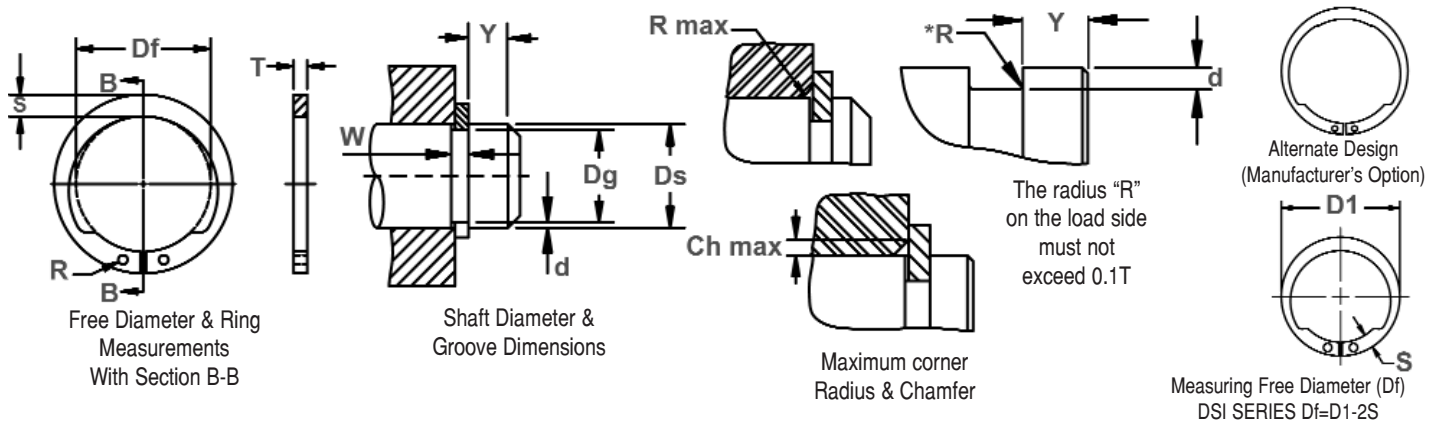

RING NO.	SHAFT DIA.	GROOVE SIZE					RING SIZE & WEIGHT						SUPPLEMENTARY DATA						
		DIAMETER		WIDTH	DEPTH		THICKNESS ***		FREE DIAMETER		MAX. SEC.	HOLE DIA.	WEIGHT	EDGE MARGIN	THRUST LOAD Ring	THRUST LOAD Groove	Allowable Rad/ Cham.	Max. load w/ R/Ch. Max.	RPM Limits
		Ds	Dg	Tol.	W Min.	d	T	Tol.	Df	Tol.	S	Tol.	R Min.	kg/ 1000	Y Min.	Pr kN	Pg kN	R/Ch Max.	P'r kN
DSI-40	40	37.5		1.85	1.25	1.75		36.50		4.7		2.0	6.49	3.8	42.0	12.60	2.0	7.8	15000
DSI-42	42	39.5		1.85	1.25	1.75		38.50		4.7		2.0	6.51	3.8	42.0	13.30	2.0	7.8	13000
DSI-45	45	42.5	-0.25	1.85	1.25	1.75	-0.06	41.50	+0.39	4.7		2.0	7.80	3.8	41.5	14.30	2.0	7.8	11000
DSI-47	47	44.5		1.85	1.25	1.75		43.50	-0.90	5.0		2.0	8.09	3.8	41.0	15.00	2.0	7.8	10000
DSI-48	48	45.5		1.85	1.25	1.75		44.50		5.2		2.0	8.48	3.8	41.0	15.80	2.0	7.8	10000
DSI-50	50	47.0		2.15	1.50	2.00		45.80		5.2		2.5	9.84	4.5	58.0	19.20	2.0	11.6	10000
DSI-55	55	52.0		2.15	1.50	2.00		50.80		5.8		2.5	11.42	4.5	58.0	21.00	2.5	9.3	9000
DSI-58	58	55.0		2.15	1.50	2.00		53.80		5.8		2.5	13.00	4.5	56.0	22.20	2.5	9.2	8000
DSI-60	60	57.0		2.15	1.50	2.00		55.80		5.8		2.5	13.80	4.5	55.5	23.00	2.5	9.1	7000
DSI-65	65	62.0	-0.30	2.65	1.50	2.50	-0.07	60.80		6.0		2.5	20.75	4.5	104.0	24.80	2.5	17.6	6000
DSI-70	70	67.0		2.65	1.50	2.50		65.50	+0.46	6.5		2.5	23.70	4.5	103.0	27.00	2.5	17.6	6000
DSI-72	72	69.0		2.65	1.50	2.50		67.50	-1.10	6.5		2.5	24.70	4.5	104.0	27.70	2.5	18.0	6000
DSI-75	75	72.0		2.65	1.50	2.50		70.50		6.5		2.5	27.50	4.5	100.0	29.20	2.5	17.7	5000
DSI-80	80	76.5		2.65	1.75	2.50		74.50		7.0		2.5	28.90	5.3	96.0	36.60	3.0	14.6	6000
DSI-82	82	78.5		2.65	1.75	2.50		76.50		7.0		2.5	29.65	5.3	100.0	37.40	3.0	15.4	5000
DSI-85	85	81.5		3.15	1.75	3.00		79.50		7.4		3.0	39.50	5.3	167.0	38.30	3.0	25.6	5000
DSI-87	87	83.5	-0.35	3.15	1.75	3.00	-0.08	81.50		7.4		3.0	40.00	5.3	164.0	39.20	3.0	25.5	5000
DSI-90	90	86.5		3.15	1.75	3.00		84.50	+0.54	7.4		3.0	41.92	5.3	157.0	41.70	3.0	24.8	4000
DSI-95	95	91.5		3.15	1.75	3.00		89.50	-1.30	8.0		3.0	47.70	5.3	152.0	42.70	3.5	21.0	4000
DSI-100	100	96.5		3.15	1.75	3.00		94.50		8.0		3.0	49.92	5.3	144.0	45.80	3.5	20.5	4000

*** FOR PLATED RINGS, ADD 0.05 TO THE LISTED MAXIMUM THICKNESS. MAXIMUM RING THICKNESS WILL BE A MINIMUM OF 0.005 LESS THAN THE LISTED GROOVE WIDTH (W) MINIMUM.

ALL DIMENSIONS IN MILLIMETERS.

HARDNESS RANGES: STAINLESS STEEL RINGS (DIN 1.4122 X39CrMo17)

RING TYPE	SIZE RANGE	HARDNESS			
		HV	HRC	15N	30N
DSI	ALL	470-580	47-54	84-87.5	66-72

HARDNESS RANGES: CARBON STEEL RINGS (SAE 1060-1090)

RING TYPE	SIZE RANGE	HARDNESS		
		VICKERS	ROCKWELL	
			HRC	LOWER SCALE*
DSI	12-17	470-580	47-54	66-72 HR30N
	18-48	470-580	47-54	-
	50-100	435-530	44-51	-

*WHERE APPLICABLE





DST Shaft Rings

(DIN 983)

Axially Assembled, External Teeth, Metric

Similar in design to the DSH external ring, this features several "teeth" equally distributed along the circumference of the ring. The increased shoulder offered by the teeth is particularly effective in retaining applications with large radii or chamfers.

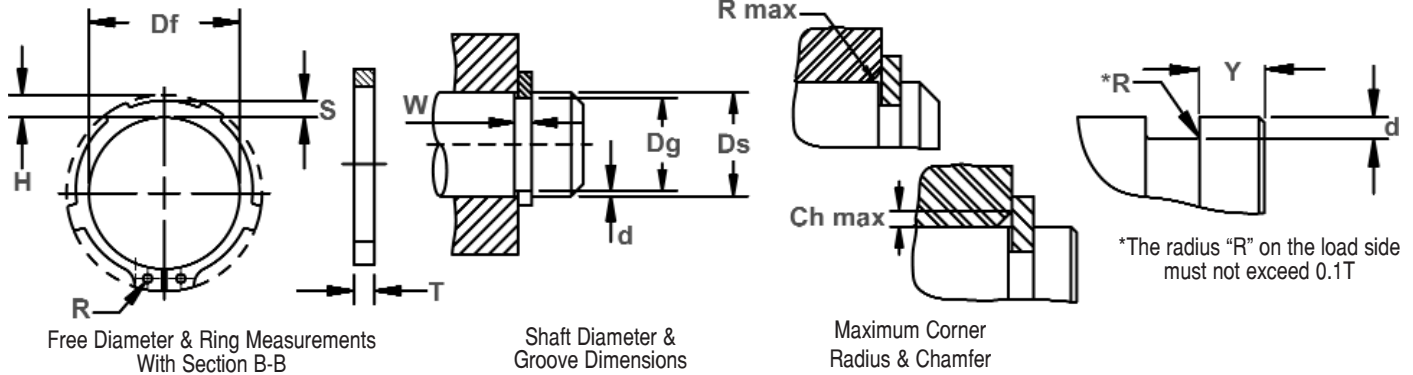

RING NO.	SHAFT DIA.	GROOVE SIZE					RING SIZE & WEIGHT						SUPPLEMENTARY DATA							
		DIAMETER		WIDTH	DEPTH		THICKNESS ***		FREE DIAMETER		LUG HT.	MAX. SEC.	HOLE DIA.	WEIGHT	EDGE MARGIN	THRUST LOAD Ring	THRUST LOAD Groove	Allowable Rad/ Cham.	Max. load w/ R/Ch. Max.	RPM Limits
		Ds	Dg	Tol.	W	d	T	Tol.	Df	Tol.	H Max.	S	R Min.	kg/ 1000	Y	Pr kN	Pg kN	R/Ch Max.	P'r kN	
DST-16	16	15,2	-0,11	1,10	0,40	1,00	-0,06	14,7	+0,10	3,5	2,3	1,7	0,82	1,2	7,4	3,26	1,0	2,4	45000	
DST-17	17	16,2		1,10	0,40	1,00		15,7		3,6	2,4	1,7	0,93	1,2	8,0	3,46	1,0	2,4	41000	
DST-18	18	17,0		1,30	0,50	1,20		16,5		-0,36	3,7	2,5	2,0	1,24	1,5	17,0	4,58	1,5	3,7	38000
DST-19	19	18,0	1,30	0,50	1,20	17,5		+0,13	3,7	2,6	2,0	1,35	1,5	17,0	4,85	1,5	3,8	33000		
DST-20	20	19,0	1,30	0,50	1,20	18,5			3,8	2,6	2,0	1,45	1,5	17,1	5,06	1,5	3,8	30000		
DST-22	22	21,0	1,30	0,50	1,20	20,5			4,0	2,8	2,0	1,77	1,5	16,9	5,65	1,5	3,8	26000		
DST-23	23	22,0	-0,15	1,30	0,50	1,20		21,5	-0,42	4,1	2,9	2,0	1,84	1,5	16,6	5,90	1,5	3,8	24000	
DST-24	24	22,9		1,30	0,55	1,20		22,2	4,2	3,0	2,0	1,98	1,6	16,1	6,75	1,5	3,6	26000		
DST-25	25	23,9		1,30	0,55	1,20		23,2	4,3	3,0	2,0	2,12	1,6	16,2	7,05	1,5	3,7	24000		
DST-26	26	24,9	-0,21	1,30	0,55	1,20		24,2	+0,21	4,4	3,1	2,0	2,18	1,6	16,1	7,34	1,5	3,7	22000	
DST-28	28	26,6		1,60	0,70	1,50	25,9	4,5		3,3	2,0	3,15	2,1	32,1	10,00	1,5	7,5	20000		
DST-29	29	27,6		1,60	0,70	1,50	26,9	-0,42		4,7	3,4	2,0	3,35	2,1	31,8	10,30	1,5	7,4	19000	
DST-30	30	28,6	-0,25	1,60	0,70	1,50	27,9	+0,25	4,7	3,4	2,0	3,65	2,1	32,1	10,70	1,5	7,6	18000		
DST-32	32	30,3		1,60	0,85	1,50	29,6		5,0	3,6	2,5	4,00	2,5	31,2	13,80	2,0	5,5	16000		
DST-34	34	32,3		1,60	0,85	1,50	31,5		5,1	3,8	2,5	4,15	2,5	31,3	14,70	2,0	5,6	16000		
DST-35	35	33,0		1,60	1,00	1,50	32,2	-0,50	5,2	3,8	2,5	4,38	3,0	30,8	17,80	2,0	5,5	15000		
DST-37	37	35,0		1,85	1,00	1,75	34,2	5,4	4,0	2,5	6,30	3,0	50,0	18,80	2,0	9,1	13000			
DST-38	38	36,0		1,85	1,00	1,75	35,2	5,5	4,1	2,5	6,50	3,0	49,5	19,30	2,0	9,1	13000			
DST-40	40	37,5		1,85	1,25	1,75	36,5	7,2	4,2	2,5	7,00	3,8	51,0	25,30	2,0	9,5	14000			
DST-42	42	39,5		1,85	1,25	1,75	38,5	+0,39	7,2	4,5	2,5	7,50	3,8	50,0	26,70	2,0	9,4	13000		
DST-45	45	42,5		1,85	1,25	1,75	41,5	-0,90	7,2	4,6	2,5	8,50	3,8	49,0	28,60	2,0	9,3	11000		
DST-47	47	44,5		1,85	1,25	1,75	43,5	7,2	4,8	2,5	8,70	3,8	49,5	30,00	2,0	9,5	10000			

*** FOR PLATED RINGS, ADD 0.05 TO THE LISTED MAXIMUM THICKNESS. MAXIMUM RING THICKNESS WILL BE A MINIMUM OF 0.005 LESS THAN THE LISTED GROOVE WIDTH (W) MINIMUM.

ALL DIMENSIONS IN MILLIMETERS.

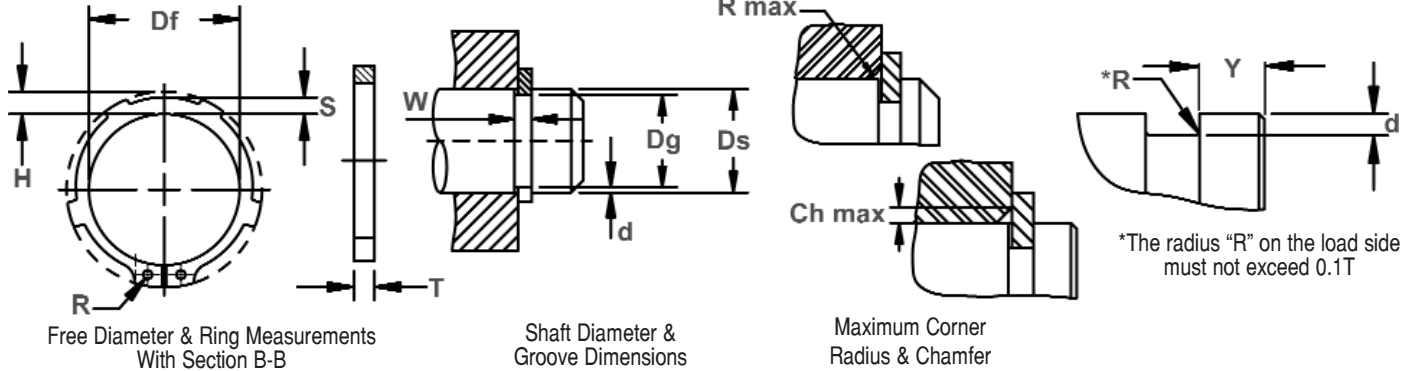

*The radius "R" on the load side must not exceed 0.1T

RING NO.	SHAFT DIA.	GROOVE SIZE					RING SIZE & WEIGHT							SUPPLEMENTARY DATA						
		DIAMETER		WIDTH	DEPTH		THICKNESS ***		FREE DIAMETER		LUG HT.	MAX. SEC.	HOLE DIA.	WEIGHT	EDGE MARGIN	THRUST LOAD Ring	THRUST LOAD Groove	Allowable Rad/Cham.	Max. load w/ R/Ch. Max.	RPM Limits
		Ds	Dg	Tol.	W	d	T	Tol.	Df	Tol.	H Max.	S	R Min.	kg/1000	Y	Pr kN	Pg kN	R/Ch Max.	Pr kN	
DST-48	48	45.5	-0,25	1,85	1,25	1,75	-0,06	44,5	+0,39	7,2	4,9	2,5	8,90	3,8	49,4	30,70	2,0	9,5	9000	
DST-50	50	47,0		2,15	1,50	2,00		45,8	-0,90	8,2	5,0	2,5	11,50	4,5	73,3	38,00	2,0	14,4	10000	
DST-55	55	52,0		2,15	1,50	2,00		50,8		8,2	5,4	2,5	12,99	4,5	71,4	42,00	2,5	11,4	8000	
DST-57	57	54,0		2,15	1,50	2,00		52,8		8,2	5,6	2,5	14,00	4,5	70,9	43,70	2,5	11,4	8000	
DST-58	58	55,0		2,15	1,50	2,00		53,8		8,2	5,7	2,5	14,30	4,5	71,1	44,30	2,5	11,5	8000	
DST-60	60	57,0		2,15	1,50	2,00		55,8		8,2	5,8	2,5	14,80	4,5	69,3	46,00	2,5	11,3	7000	
DST-62	62	59,0		2,15	1,50	2,00	-0,07	57,8		8,2	5,9	2,5	15,90	4,5	69,3	47,50	2,5	11,4	7000	
DST-65	65	62,0	-0,30	2,65	1,50	2,50		60,8	+0,46	10,2	6,2	3,0	21,70	4,5	135,0	49,80	2,5	22,7	6000	
DST-67	67	64,0		2,65	1,50	2,50		62,5	-1,10	10,2	6,4	3,0	22,60	4,5	136,0	51,30	2,5	23,0	7000	
DST-68	68	65,0		2,65	1,50	2,50		63,5		10,2	6,5	3,0	23,50	4,5	135,0	52,20	2,5	23,0	7000	
DST-70	70	67,0		2,65	1,50	2,50		65,5		10,2	6,6	3,0	25,10	4,5	134,0	53,80	2,5	23,0	6000	
DST-75	75	72,0		2,65	1,50	2,50		70,5		10,2	7,0	3,0	28,20	4,5	130,0	57,60	2,5	22,8	6000	
DST-80	80	76,5		2,65	1,75	2,50		74,5		10,2	7,4	3,0	30,75	5,3	128,0	71,60	3,0	19,5	6000	
DST-85	85	81,5	-0,35	3,15	1,75	3,00		79,5		10,2	7,8	3,5	39,50	5,3	215,0	76,20	3,0	33,4	5000	
DST-90	90	86,5		3,15	1,75	3,00	-0,08	84,5		10,2	8,2	3,5	47,70	5,3	217,0	80,20	3,0	33,4	5000	
DST-95	95	91,5		3,15	1,75	3,00		89,5		10,2	8,6	3,5	53,00	5,3	212,0	85,50	3,5	29,3	4000	
DST-100	100	96,5		3,15	1,75	3,00		94,5	+0,54	10,2	9,0	3,5	56,60	5,3	206,0	90,00	3,5	29,0	4000	
DST-110	110	106,0	-0,54	4,15	2,00	4,00		103,0	-1,30	12,2	9,6	3,5	84,60	6,0	457,0	113,00	3,5	66,9	4000	
DST-120	120	116,0		4,15	2,00	4,00	-0,10	113,0		14,2	10,1	3,5	89,70	6,0	424,0	123,00	3,5	64,5	4000	
DST-130	130	126,0	-0,63	4,15	2,00	4,00		123,0		14,2	10,7	4,0	105,00	6,0	395,0	134,00	4,0	55,2	3000	
DST-140	140	136,0		4,15	2,00	4,00		133,0		14,2	11,2	4,0	115,00	6,0	376,0	144,00	4,0	54,4	3000	

*** FOR PLATED RINGS, ADD 0.05 TO THE LISTED MAXIMUM THICKNESS. MAXIMUM RING THICKNESS WILL BE A MINIMUM OF 0.005 LESS THAN THE LISTED GROOVE WIDTH (W) MINIMUM.

ALL DIMENSIONS IN MILLIMETERS.

NUMBER OF TEETH (INCLUDING LUGS)

RING TYPE	SIZE RANGE	# TEETH
DST	16-58	6
	60-140	8

HARDNESS RANGES: STAINLESS STEEL RINGS (DIN 1.4122 X39CrMo17)

RING TYPE	SIZE RANGE	HARDNESS			
		HV	HRC	15N	30N
DST	ALL	470-580	47-54	84-87.5	66-72

HARDNESS RANGES: CARBON STEEL RINGS (SAE 1060-1090)

RING TYPE	SIZE RANGE	HARDNESS		
		VICKERS	ROCKWELL	
			HRC	LOWER SCALE*
DST	16 & 17	470-580	47-54	66-72 HR30N
	18-48	470-580	47-54	-
	50-140	435-530	44-51	-

*WHERE APPLICABLE





DE Shaft Rings (DIN 6799)

Radially Assembled, External E, Metric

Perhaps the most popular and widely used radial retaining ring is the "E" (so named because it is shaped like the letter "E").

Three prongs make contact with the bottom of the groove and provide a shoulder for effective retention of assemblies.

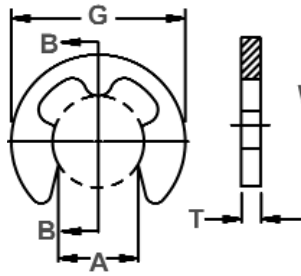

Ring Measurements

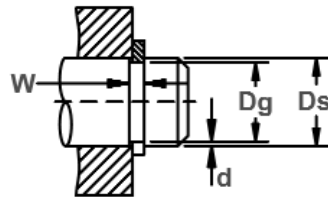

Shaft Diameter & Groove Dimensions

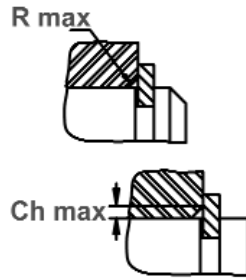

Maximum Corner Radius & Chamfer

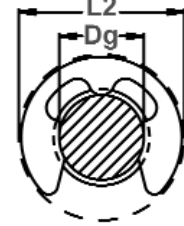

Clearance Diameter Installed In Groove

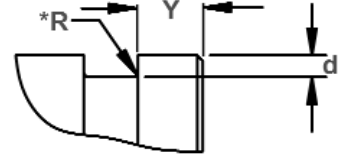

Edge Margin (Y)
The radius "R" on the load side must not exceed 0.1T.

RING NO.	NOM SIZE	SHAFT DIA. (mm)		GROOVE SIZE				RING SIZE & WEIGHT				CLEARANCE				SUPPLEMENTARY DATA					
		Dg	From	To	Dg	Tol.	W	Tol.	T	Tol.	A	Tol.	kg/1000	G Ref.	L2 Max.	Y Min.	Pr kN	Pg kN	Ds'	R/Ch Max.	P'r kN
DE-0.8	0.8	1	1.4	0.8	-0.04	0.24	+0.04	0.2		0.58		0.003	1.95	2.25	0.4	0.08	0.03	1.2	0.3	0.04	50000
DE-1.2	1.2	1.4	2.0	1.2		0.34	-0.00	0.3		1.01		0.009	2.9	3.25	0.6	0.12	0.04	1.5	0.4	0.06	47000
DE-1.5	1.5	2.0	2.5	1.5	-0.06	0.44		0.4		1.28	±0.04	0.021	3.9	4.25	0.8	0.22	0.07	2.0	0.6	0.11	42000
DE-1.9	1.9	2.5	3.0	1.9		0.54		0.5		1.61		0.040	4.40	4.8	1.0	0.35	0.10	2.5	0.7	0.17	40000
DE-2.3	2.3	3.0	4.0	2.3		0.64		0.6		1.94		0.069	5.90	6.3	1.0	0.50	0.15	3.0	0.9	0.24	38000
DE-3.2	3.2	4.0	5.0	3.2		0.64		0.6	±0.02	2.70		0.088	6.90	7.3	1.0	0.65	0.22	4.0	0.9	0.32	35000
DE-4	4.0	5.0	7.0	4.0	-0.075	0.74	+0.05	0.7		3.34		0.158	8.85	9.3	1.2	0.95	0.25	5.0	1.0	0.47	32000
DE-5	5.0	6.0	8.0	5.0		0.74	-0.00	0.7		4.11	±0.048	0.236	10.85	11.3	1.2	1.15	0.90	7.0	1.0	0.60	28000
DE-6	6.0	7.0	9.0	6.0		0.74		0.7		5.26		0.255	11.8	12.3	1.2	1.35	1.10	8.0	1.1	0.70	25000
DE-7	7.0	8.0	11.0	7.0		0.94		0.9		5.84		0.474	13.8	14.3	1.5	1.80	1.25	9.0	1.3	1.00	22000
DE-8	8.0	9.0	12.0	8.0	-0.09	1.05		1.0		6.52		0.660	15.75	16.3	1.8	2.50	1.42	10.0	1.5	1.25	20000
DE-9	9.0	10.0	14.0	9.0		1.15		1.1		7.63	±0.058	1.090	18.20	18.8	2.0	3.00	1.60	11.0	1.6	1.50	17000
DE-10	10.0	11.0	15.0	10.0		1.25		1.2		8.32		1.250	19.70	20.4	2.0	3.50	1.70	12.0	1.8	1.75	15000
DE-12	12.0	13.0	18.0	12.0	-0.11	1.35	+0.08	1.3	±0.03	10.45		1.630	22.7	23.4	2.5	4.70	3.10	15.0	1.9	2.30	13000
DE-15	15.0	16.0	24.0	15.0		1.55	-0.00	1.5		12.61	±0.07	3.370	28.70	29.4	3.0	7.80	7.00	20.0	2.2	3.30	11000
DE-19	19.0	20.0	31.0	19.0		1.80		1.75		15.92		6.420	36.50	37.6	3.5	11	10.00	25.0	2.5	3.60	7600
DE-24	24.0	25.0	38.0	24.0	-0.13	2.05		2.00		21.88	±0.084	8.550	43.50	44.6	4.0	15	13.00	30.0	3.0	4.00	5500
DE-30	30.0	32.0	42.0	30.0		2.55		2.50		25.80		13.50	51.3	52.6	4.5	23.00	16.50	36.0	3.5	5.30	4200

*SHARP CORNER ABUTMENT.

ALL DIMENSIONS IN MILLIMETERS.

The radius "R" on the load side must not exceed 0.1T.

*** FOR PLATED RINGS, ADD 0.05 TO THE LISTED MAXIMUM THICKNESS. MAXIMUM RING THICKNESS WILL BE A MINIMUM OF 0.005 LESS THAN THE LISTED GROOVE WIDTH (W) MINIMUM.

NOTE: GROOVE WIDTH MUST BE INCREASED FOR PLATED PARTS. PLEASE CONTACT TECHNICAL SALES FOR ADDITIONAL INFORMATION: tech@rotorclip.com.

HARDNESS RANGES: STAINLESS STEEL RINGS (PH 15-7MO)

RING TYPE	SIZE RANGE	HARDNESS		
		VICKERS	ROCKWELL	
DE	0.8-1.5	435-530	HRC	LOWER SCALE*
			44-51	82.5-86 HR15N**
			44-51	82.5-86 HR15N
			44-51	63-69.5 HR30N
DE	10-30	435-530	HRC	-
			44-51	-

*WHERE APPLICABLE

**HARDNESS CAN NOT BE CHECKED WITH ANY DEGREE OF ACCURACY DIRECTLY ON THESE RINGS.

HARDNESS RANGES: STAINLESS STEEL RINGS (DIN 1.4122 X39CrMo17)

RING TYPE	SIZE RANGE	HARDNESS			
		HV	HRC	15N	30N
DE	ALL	470-580	47-54	84-87.5	66-72

Installation tools can be found at rotorclip.com/pliers_tools_applicators_kits

HARDNESS RANGES: BERYLLIUM COPPER RINGS

RING TYPE	SIZE RANGE	HARDNESS		
		VICKERS	ROCKWELL	
DE	0.8-1.5	360-415	HRC	LOWER SCALE*
			37-43	79-82 HR15N**
			37-43	79-82 HR15N
			37-43	56.5-62 HR30N
DE	10-30	360-415	HRC	-
			37-43	-

*WHERE APPLICABLE

**HARDNESS CAN NOT BE CHECKED WITH ANY DEGREE OF ACCURACY DIRECTLY ON THESE RINGS.

HARDNESS RANGES: CARBON STEEL RINGS (SAE 1060-1090)

RING TYPE	SIZE RANGE	HARDNESS		
		VICKERS	ROCKWELL	
DE	0.8-1.5	460-580	HRC	LOWER SCALE*
			46-54	83.5-87.5 HR15N**
			46-54	83.5-87.5 HR15N
			46-54	65-72 HR30N
DE	10-30	460-580	HRC	-
			46-54	-

*WHERE APPLICABLE

**HARDNESS CAN NOT BE CHECKED WITH ANY DEGREE OF ACCURACY DIRECTLY ON THESE RINGS.



External, Self-Locking Friction, Metric

The DSF ring resembles a regular DSH ring except that it is designed to function on a shaft without a groove. The design of the ring causes it to exert significant gripping power uniformly on the shaft (except where the gap occurs.)

DSF Shaft Rings

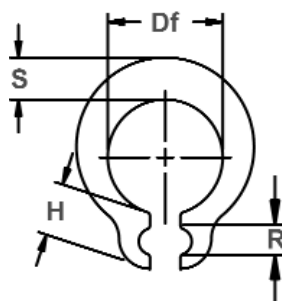

Free Diameter & Ring Measurements

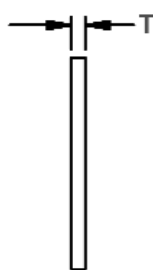

Shaft Diameter

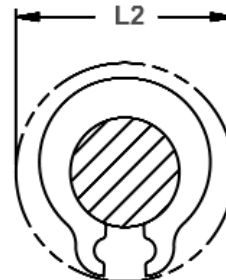
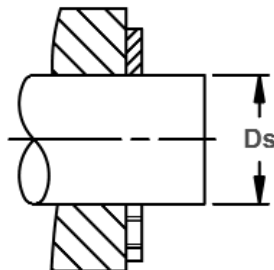

Clearance Diameter Installed on Shaft

RING NO.	SHAFT DIA. (mm)	RING SIZE & WEIGHT						SUPPLEMENTARY DATA			
		FREE DIAMETER		THICKNESS	LUG HEIGHT	MAX. SECTION	NOTCH	WEIGHT	CLEARANCE Released Over Shaft	THRUST LOAD	RPM Limits
		Ds	Df Tol.	T	H Max.	S Ref.	R Min.	kg/1000	L2	Pr kN	
DSF-1,5	1,5	1,40	±0,02	0,4	1,7	0,7	0,9	0,013	5,1	40	350000
DSF-2	2	1,90		0,6	1,9	1,0	0,9	0,036	6,0	50	260000
DSF-2,2	2,2	2,05	±0,025	0,6	1,9	1,1	0,9	0,038	6,2	50	270000
DSF-2,5	2,5	2,35	±0,030	0,6	1,9	1,2	0,9	0,045	6,5	60	220000
DSF-2,8	2,8	2,65	±0,035	0,6	2,0	1,3	0,9	0,057	7,0	70	190000
DSF-3	3	2,85	±0,04	0,6	2,1	1,4	0,9	0,065	7,4	75	170000
DSF-3,5	3,5	3,30	±0,05	0,6	2,3	1,6	0,9	0,081	8,3	90	150000
DSF-4	4	3,80	±0,06	0,8	2,7	1,8	1,2	0,154	9,6	100	125000
DSF-4,5	4,5	4,25		0,8	2,9	2,0	1,3	0,173	10,5	120	120000
DSF-5	5	4,75	±0,075	0,8	2,9	2,2	1,3	0,200	11,0	130	100000
DSF-5,5	5,5	5,20		0,8	3,0	2,2	1,3	0,216	11,7	150	90000
DSF-6	6	5,70		1,00	3,2	2,4	1,4	0,402	12,6	170	81000
DSF-7	7	6,70	±0,09	1,00	3,4	2,7	1,4	0,428	14,0	180	63000
DSF-8	8	7,70		1,00	3,5	3,0	1,4	0,524	15,2	200	52000
DSF-9	9	8,65		1,20	4,7	3,3	2,0	0,808	18,6	230	46000
DSF-10	10	9,65	±0,11	1,20	4,7	3,5	2,0	0,944	19,6	250	39000
DSF-10,5	10,5	10,20		1,20	4,0	3,8	1,5	1,100	18,7	260	34000
DSF-11	11	10,60		1,20	4,8	4,2	2,0	1,208	20,8	280	37000
DSF-12	12	11,60	±0,13	1,20	4,8	4,6	2,0	1,454	21,8	300	33000
DSF-13	13	12,55		1,20	5,3	5,0	2,0	1,750	23,8	320	31000
DSF-13,8	13,8	13,30		1,50	5,1	5,4	2,2	2,492	24,8	350	30000
DSF-14	14	13,50	±0,11	1,50	5,1	5,4	2,2	2,456	25,0	350	29000
DSF-15	15	14,50		1,50	5,1	5,6	2,2	2,716	26,4	400	26000
DSF-16	16	15,40		1,50	5,6	5,8	2,5	2,940	27,8	500	26000
DSF-17	17	16,35	±0,13	1,75	6,0	6,2	2,5	4,010	29,5	600	24000
DSF-18	18	17,30		1,75	6,1	6,6	2,5	4,460	31,4	700	23000
DSF-20	20	19,30		1,75	6,1	7,1	2,5	5,270	34,4	700	20000
DSF-22	22	21,20	±0,13	1,75	6,6	7,4	2,5	6,060	37,0	750	18000
DSF-24	24	23,15		1,75	6,6	7,8	2,5	7,000	39,8	750	16000
DSF-25	25	24,15		1,75	6,6	8,2	2,5	7,450	41,6	750	15000
DSF-30	30	29,00	1,75	9,0	9,0	2,5	10,000	48,2	750	12000	

ALL DIMENSIONS IN MILLIMETERS.

HARDNESS RANGES: STAINLESS STEEL RINGS (DIN 1.4122 X39CrMo17)

RING TYPE	SIZE RANGE	HARDNESS			
		HV	HRC	15N	30N
DSF	ALL	470-580	47-54	84-87,5	66-72

HARDNESS RANGES: CARBON STEEL RINGS (SAE 1060-1090)

RING TYPE	SIZE RANGE	HARDNESS		
		VICKERS	ROCKWELL	
			HRC	LOWER SCALE*
DSF	1-5	485-560	48-53	84.5-87 HR15N**
	2-8	485-560	48-53	66.5-71 HR30N
	9-30	485-560	48-53	-

*WHERE APPLICABLE

**HARDNESS CAN NOT BE CHECKED WITH ANY DEGREE OF ACCURACY DIRECTLY ON THESE RINGS.



DC Shaft Rings

Radially Assembled, External Crescent, Metric

Ideal for low clearance applications where radial installation is preferred.

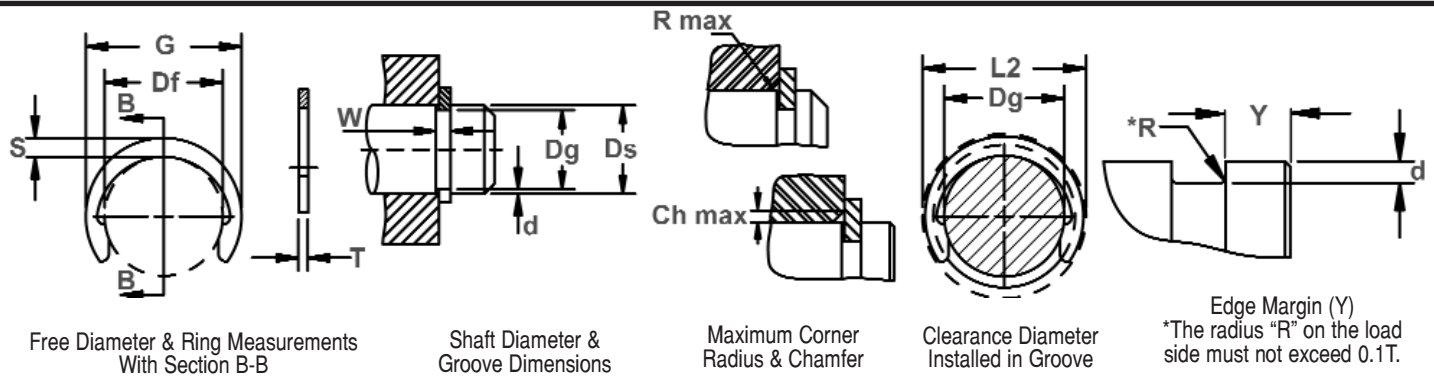

RING NO.	SHAFT DIA. (mm)	GROOVE SIZE					RING SIZE & WEIGHT					CLEARANCE				SUPPLEMENTARY DATA				
		DIAMETER		WIDTH	DEPTH		THICKNESS ***		FREE DIAMETER		MAX. SEC.	WGHT.	FREE O.D.	INSTALLED IN GROOVE	EDGE MARGIN	THRUST LOAD	THRUST LOAD	Allowable Rad/Cham	Max Load (lbs.)	RPM Limits
		Ds	Dg	Tol.	W Min.	d Ref.	T	Tol.	Df	Tol.	S max ref.	kg/1000	G Ref.	L2 Max.	Y Min.	Pr kN	Pg kN	R/Ch Max.	P'r kN	
DC-3	3	2,3		0,44	0,35	0,40		2,18	±0,06	0,90	0,02	3,98	4,1	1,0	0,50	0,24	0,40	0,40	95000	
DC-4	4	3,2	-0,07	0,44	0,40	0,40		3,00		1,00	0,04	5,00	5,2	1,2	0,50	0,37	0,40	0,40	90000	
DC-5	5	4,0		0,64	0,50	0,60	-0,05	3,80		1,20	0,08	6,20	6,4	1,5	1,10	0,58	0,60	0,70	88000	
DC-6	6	5,0		0,74	0,50	0,70		4,80	±0,08	1,30	0,11	7,40	7,6	1,5	1,65	0,72	0,70	1,10	80000	
DC-7	7	6,0		0,85	0,50	0,80		5,80		1,40	0,13	8,60	8,8	1,5	2,20	0,85	0,80	1,30	69000	
DC-8	8	7,0	-0,09	0,85	0,50	0,80		6,80		1,60	0,17	10,00	10,2	1,5	2,20	0,98	0,80	1,30	67000	
DC-9	9	8,0		1,10	0,50	1,00		7,80	±0,09	1,70	0,22	11,20	11,4	1,5	3,50	1,10	1,00	2,00	58000	
DC-10	10	9,0		1,10	0,50	1,00		8,75		1,70	0,26	12,15	12,4	1,5	3,70	1,24	1,00	2,00	50000	
DC-11	11	10,0		1,10	0,50	1,00		9,65		1,80	0,29	13,20	13,6	1,5	4,00	1,35	1,00	2,00	40000	
DC-12	12	10,9		1,10	0,55	1,00		10,55		1,90	0,32	14,35	14,7	1,7	4,20	1,65	1,00	2,00	35000	
DC-13	13	11,8		1,10	0,60	1,00		11,40		2,00	0,36	15,40	15,8	1,8	4,50	1,90	1,00	2,00	30000	
DC-14	14	12,7		1,10	0,65	1,00	-0,06	12,30		2,00	0,40	16,30	16,7	2,0	5,00	2,20	1,00	2,00	27000	
DC-15	15	13,6	-0,11	1,10	0,70	1,00		13,20	±0,18	2,10	0,46	17,40	17,8	2,1	5,50	2,60	1,00	2,00	25000	
DC-16	16	14,5		1,10	0,75	1,00		14,10		2,20	0,54	18,50	18,9	2,3	5,80	3,00	1,00	2,00	24000	
DC-17	17	15,4		1,10	0,80	1,00		14,90		2,25	0,64	19,40	19,9	2,4	6,00	3,40	1,00	2,00	23000	
DC-18	18	16,3		1,30	0,85	1,20		15,80		2,30	0,72	20,40	20,9	2,6	8,50	3,70	1,20	2,80	21000	
DC-19	19	17,2		1,30	0,90	1,20		16,70		2,40	0,80	21,50	22,0	2,7	9,00	4,30	1,20	2,80	21000	
DC-20	20	18,1	-0,21	1,30	0,95	1,20		17,55		2,55	0,87	22,65	23,2	2,9	9,40	4,70	1,20	3,00	20000	

ALL DIMENSIONS IN MILLIMETERS.

*The radius "R" on the load side must not exceed 0.1 T

*** FOR PLATED RINGS, ADD 0.05 TO THE LISTED MAXIMUM THICKNESS. MAXIMUM RING THICKNESS WILL BE A MINIMUM OF 0.005 LESS THAN THE LISTED GROOVE WIDTH (W) MIN.

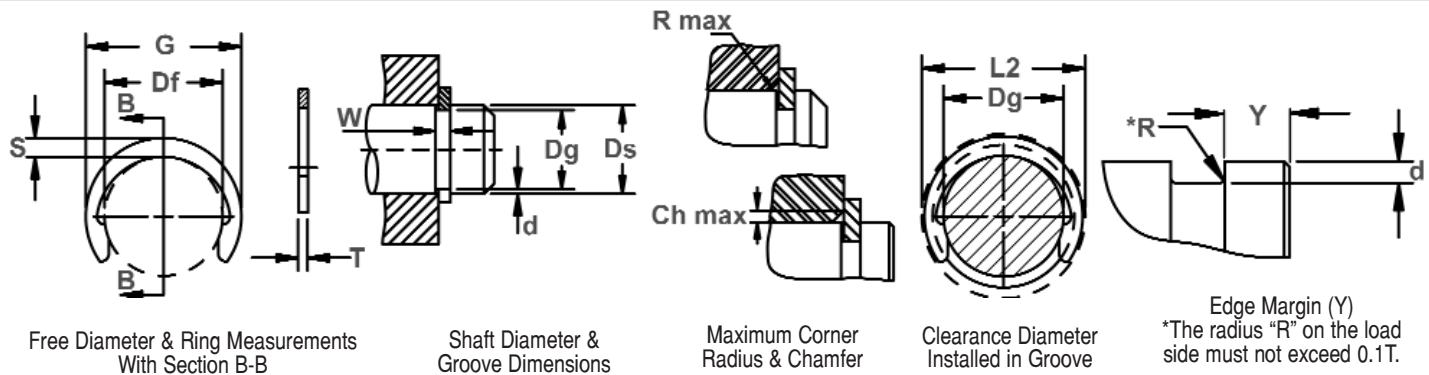

Edge Margin (Y)
*The radius "R" on the load side must not exceed 0.1T.

RING NO.	SHAFT DIA. (mm)	GROOVE SIZE					RING SIZE & WEIGHT					CLEARANCE				SUPPLEMENTARY DATA				
		DIAMETER		WIDTH	DEPTH		THICKNESS ***		FREE DIAMETER		MAX. SEC.	WGHT.	FREE O.D.	INSTALLED IN GROOVE	EDGE MARGIN	THRUST LOAD	THRUST LOAD	Allowable Rad/Cham	Max Load (lbs.)	RPM Limits
		Ds	Dg	Tol.	W Min.	d Ref.	T	Tol.	Df	Tol.	S max ref.	kg/1000	G Ref.	L2 Max.	Y Min.	Pr kN	Pg kN	R/Ch Max.	P'r kN	
DC-22	22	19.9		1.30	1.05	1.20		19.40		2.80	1.10	25.00	25.5	3.2	10.00	5.70	1.20	3.00	17000	
DC-23	23	20.8		1.30	1.10	1.20		20.20		2.90	1.15	26.00	26.6	3.3	10.50	6.20	1.20	3.20	15000	
DC-24	24	21.7		1.30	1.15	1.20		21.10		3.00	1.52	27.10	27.7	3.5	11.00	6.80	1.20	3.20	15000	
DC-25	25	22.6	-0.21	1.30	1.20	1.20		22.00	±0.21	3.15	1.74	28.30	28.9	3.6	11.50	7.50	1.20	3.20	15000	
DC-26	26	23.5		1.30	1.25	1.20		22.90		3.25	1.88	29.40	30.0	3.8	12.00	8.00	1.20	3.20	15000	
DC-28	28	25.2		1.60	1.40	1.50		24.60		3.50	2.32	31.60	32.2	4.2	16.50	9.70	1.50	5.50	13000	
DC-30	30	27.0		1.60	1.50	1.50		26.30		3.70	2.43	33.70	34.4	4.5	17.00	11.00	1.50	5.60	13000	
DC-32	32	28.8		1.60	1.60	1.50	-0.06	28.10		4.00	3.02	36.10	36.8	4.6	18.00	12.50	1.50	5.80	13000	
DC-35	35	31.5		1.60	1.75	1.50		30.80		4.30	3.30	39.40	40.1	5.3	20.00	15.00	1.50	5.80	11000	
DC-36	36	32.4		1.85	1.80	1.75		31.70	±0.25	4.40	4.40	40.50	41.2	5.4	25.00	16.00	1.75	8.30	10000	
DC-38	38	34.2		1.85	1.90	1.75		33.40		4.60	4.62	42.60	43.4	5.7	26.00	17.50	1.75	8.50	10000	
DC-40	40	36.0		1.85	2.00	1.75		35.20		4.90	5.05	45.00	45.8	6.0	27.50	20.00	1.75	8.80	9000	
DC-42	42	37.8	-0.25	1.85	2.10	1.75		37.00		5.10	5.46	47.20	48.0	6.3	28.00	21.50	1.75	8.90	9000	
DC-45	45	40.5		1.85	2.25	1.75		39.60		5.50	5.98	50.60	51.5	6.8	30.00	25.00	1.75	9.00	8000	
DC-48	48	43.2		1.85	2.40	1.75		42.30	±0.39	5.90	7.82	54.10	55.0	7.2	32.00	28.00	1.75	9.00	8000	
DC-50	50	45.0		2.15	2.50	2.00		44.00		6.20	8.85	56.40	57.4	7.5	39.50	31.00	2.00	12.00	7000	
DC-52	52	47.0		2.15	2.50	2.00	-0.07	46.00		6.30	9.33	58.60	59.6	7.5	41.00	32.00	2.00	12.00	7000	
DC-55	55	50.0		2.15	2.50	2.00		48.50		6.50	10.40	61.50	63.0	7.5	43.00	34.00	2.00	12.00	7000	

ALL DIMENSIONS IN MILLIMETERS.

*The radius "R" on the load side must not exceed 0.1 T

*** FOR PLATED RINGS, ADD 0.05 TO THE LISTED MAXIMUM THICKNESS. MAXIMUM RING THICKNESS WILL BE A MINIMUM OF 0.005 LESS THAN THE LISTED GROOVE WIDTH (W) MIN.

HARDNESS RANGES: STAINLESS STEEL RINGS (PH 15-7MO)

RING TYPE	SIZE RANGE	HARDNESS		
		VICKERS	ROCKWELL	
			HRC	LOWER SCALE*
DC	3 & 4	435-530	44-51	82.5-86 HR15N**
	5-17	435-530	44-51	63-69.5 HR30N
	18-55	435-530	44-51	-

*WHERE APPLICABLE

**HARDNESS CAN NOT BE CHECKED WITH ANY DEGREE OF ACCURACY DIRECTLY ON THESE RINGS.

HARDNESS RANGES: CARBON STEEL RINGS (SAE 1060-1090)

RING TYPE	SIZE RANGE	HARDNESS		
		VICKERS	ROCKWELL	
			HRC	LOWER SCALE*
DC	3 & 4	485-545	48-52	84.5-86.5 HR15N**
	5-17	485-545	48-52	66.5-70.5 HR30N
	18-55	485-545	48-52	-

*WHERE APPLICABLE

**HARDNESS CAN NOT BE CHECKED WITH ANY DEGREE OF ACCURACY DIRECTLY ON THESE RINGS.

HARDNESS RANGES: STAINLESS STEEL RINGS (DIN 1.4122 X39CrMo17)

RING TYPE	SIZE RANGE	HARDNESS			
		HV	HRC	15N	30N
DC	ALL	470-580	47-54	84-87.5	66-72





DTX Shaft Rings

Self-Locking, External "Push-On", Metric

This ring features a curved outer rim with a series of prongs protruding into the center. The ends create interference with the shaft when the ring is installed and a load introduced to the other side.

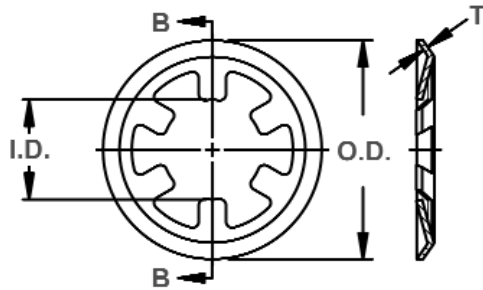

Free Diameter & Ring Measurements
With Section B-B

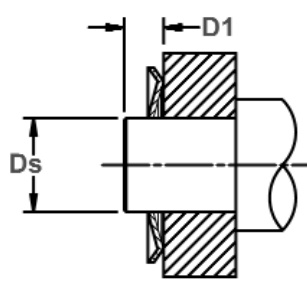

Installation View
Without Groove

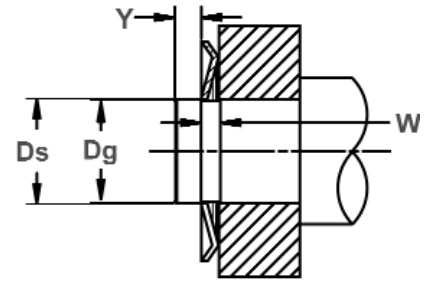

Installation View
With Groove

RING NO.	SHAFT DIAMETER		GROOVE SIZE DIMENSIONS			RING DIMENSIONS				SUPPLEMENTARY DATA			
						I.D.	O.D.	No. Of Prongs	THICK-NESS	WEIGHT Per 1000	Min. Dis-tance	THRUST LOAD	EDGE MARGIN
			Ds	TOL.	Dg								
DTX-1.5	1.5		1.40		0.4	1.40	6.0	3	0.25	0.040	1.5	100	1.0
DTX-2	2.0	+0,00	1.90	-0,060	0.4	1.85	6.5	3	0.25	0.042	1.5	150	1.0
DTX-3	3.0	-0,060	2.90		0.4	2.80	8.0	4	0.25	0.066	1.5	200	1.0
DTX-3.5	3.5		3.40		0.5	3.30	8.2	4	0.40	0.104	2.0	210	1.0
DTX-4	4.0	+0,00	3.90	-0,075	0.4	3.80	9.0	4	0.25	0.078	2.0	220	1.0
DTX-5	5.0	-0,075	4.90		0.4	4.80	10.0	4	0.25	0.082	2.0	230	1.0
DTX-6	6.0		5.90		0.4	5.80	11.0	4	0.25	0.094	2.5	240	1.5
DTX-7	7.0		6.90		0.4	6.80	12.0	5	0.25	0.110	2.5	250	1.5
DTX-8	8.0	+0,00	7.85	-0,090	0.4	7.75	13.0	5	0.25	0.122	2.5	250	1.5
DTX-9	9.0	-0,090	8.85		0.6	8.75	14.0	5	0.30	0.208	2.5	300	1.5
DTX-10	10.0		9.85		0.6	9.75	16.0	6	0.30	0.232	3.0	320	1.5
DTX-12	12.0		11.85		0.6	11.70	18.0	6	0.30	0.255	3.0	350	1.5
DTX-14	14.0		13.80	-0,110	0.6	13.70	20.5	6	0.30	0.310	3.0	400	1.5
DTX-15	15.0	+0,00	14.80		1.0	14.60	23.0	8	0.50	0.750	3.0	600	2.0
DTX-16	16.0	-0,110	15.80		1.0	15.60	24.5	8	0.40	0.710	3.0	700	2.0
DTX-17	17.0		16.80		1.0	16.60	26.0	8	0.50	0.950	3.5	800	2.0
DTX-18	18.0		17.80		1.0	17.60	27.0	8	0.40	0.810	3.5	850	2.0
DTX-19	19.0		18.80		1.0	18.60	28.0	8	0.50	0.950	3.5	900	2.0
DTX-20	20.0		19.75		1.0	19.50	29.0	8	0.50	1.090	3.5	950	2.0
DTX-22	22.0		21.75		1.0	21.50	31.0	8	0.50	1.150	3.5	1000	2.0
DTX-23	23.0	+0,00	22.75	-0,130	1.0	22.50	31.5	8	0.50	1.220	4.0	1050	2.0
DTX-25	25.0	-0,130	24.75		1.0	24.50	34.0	8	0.50	1.490	4.0	1100	2.0
DTX-28	28.0		27.75		1.0	27.50	37.0	8	0.50	1.550	4.0	1200	2.0
DTX-30	30.0		29.75		1.0	29.50	40.0	8	0.50	1.630	4.0	1300	2.0
DTX-35	35.0	+0,00	34.75		1.0	34.50	46.0	8	0.50	2.100	4.0	1400	2.0
DTX-45	45.0	-0,160	44.75		1.5	44.50	60.0	8	0.50	2.700	4.0	1500	2.0

ALL DIMENSIONS IN MILLIMETERS.

HARDNESS RANGES: STAINLESS STEEL RINGS (DIN 1.4122 X39CrMo17)

RING TYPE	SIZE RANGE	HARDNESS			
		HV	HRC	15N	30N
DTX	ALL	470-580	47-54	84-87.5	66-72

HARDNESS RANGES: STAINLESS STEEL RINGS (PH 15-7MO)

RING TYPE	SIZE RANGE	HARDNESS		
		VICKERS	ROCKWELL	
			HRC	LOWER SCALE*
DTX	1.5-14	435-530	44-51	82.5-86 HR15N**
	15-45	435-530	44-51	82.5-86 HR15N

*WHERE APPLICABLE

**HARDNESS CAN NOT BE CHECKED WITH ANY DEGREE OF ACCURACY DIRECTLY ON THESE RINGS.

HARDNESS RANGES: CARBON STEEL RINGS (SAE 1060-1090)

RING TYPE	SIZE RANGE	HARDNESS		
		VICKERS	ROCKWELL	
			HRC	LOWER SCALE*
DTX	1.5-14	450-520	45-50	83-85.5 HR15N**
	15-45	450-520	45-50	83-85.5 HR15N

*WHERE APPLICABLE

**HARDNESS CAN NOT BE CHECKED WITH ANY DEGREE OF ACCURACY DIRECTLY ON THESE RINGS.

Self-Locking, Internal "Push-On", Metric

The internal version of the TX with a curved inner rim and a series of prongs protruding outward. The ends create interference with the housing when the ring is installed and a load introduced to the other side.

DTI Housing Rings

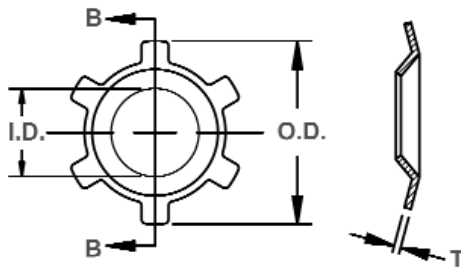

Free Diameter & Ring Measurements
With Section B-B

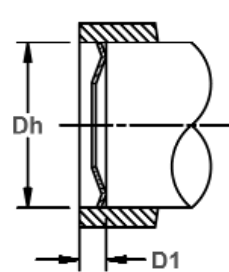

Installation View
Without Groove

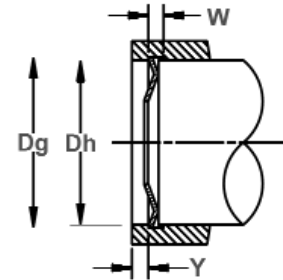

Installation View
With Groove

RING NO.	HOUSING DIAMETER		GROOVE SIZE DIMENSIONS			RING DIMENSIONS				SUPPLEMENTARY DATA			
						No. Of Prongs	THICK-NESS	WEIGHT Per 1000 Pcs.	Min. Dis-tance	THRUST LOAD	EDGE MARGIN		
												I.D.	O.D.
	Dh	TOL.	Dg	Tol.	W Min.								
DTI-8	8,0	+0,09	8,10	+0,060	0,4	4,0	8,25	6	0,25	0,048	2,0	300	1,0
DTI-10	10,0	-0,00	10,10	+0,075	0,4	5,0	10,20	6	0,25	0,068	2,0	350	1,0
DTI-12	12,0		12,10		0,4	6,0	12,25	6	0,25	0,112	2,5	450	1,0
DTI-14	14,0		14,10	0,5	8,0	14,25	6	0,30	0,172	2,5	500	1,0	
DTI-15	15,0	+0,11	15,10	0,5	9,0	15,25	6	0,30	0,192	2,5	550	1,0	
DTI-16	16,0	-0,00	16,15	0,5	10,0	16,30	6	0,30	0,206	2,5	600	1,5	
DTI-17	17,0		17,15	0,5	11,0	17,30	8	0,30	0,236	3,0	650	1,5	
DTI-18	18,0		18,15	0,8	10,5	18,30	8	0,40	0,380	3,0	700	1,5	
DTI-19,8	19,8	+0,13	20,00	+0,110	0,8	11,0	20,20	8	0,50	0,604	3,5	800	1,5
DTI-20	20,0		20,20		0,8	11,0	20,35	8	0,40	0,512	3,5	800	1,5
DTI-22	22,0	-0,00	22,20	1,0	13,0	22,35	8	0,50	0,680	3,5	800	2,0	
DTI-25	25,0		25,20	1,0	16,0	25,35	10	0,50	0,810	3,5	800	2,0	
DTI-26	26,0		26,20	1,0	17,0	26,40	10	0,50	0,856	3,5	850	2,0	
DTI-28	28,0		28,20	1,0	19,0	28,40	10	0,50	0,922	3,5	850	2,0	
DTI-30	30,0		30,20	1,0	21,0	30,40	8	0,50	1,010	4,0	900	2,0	
DTI-32	32,0		32,20	1,0	22,5	32,40	12	0,50	1,210	4,0	900	2,0	
DTI-35	35,0	+0,160	35,20	+0,130	1,0	25,0	35,40	12	0,50	1,320	4,0	900	2,0
DTI-40	40,0	-0,00	40,20		1,0	30,0	40,40	12	0,50	1,720	4,0	950	2,0
DTI-45	45,0		45,20		1,0	35,0	45,40	12	0,50	1,830	4,0	950	2,0
DTI-46	46,0		46,20		1,0	36,0	46,50	12	0,50	1,870	4,0	1000	2,0
DTI-50	50,0		50,20		1,0	39,0	50,50	12	0,50	2,160	4,0	1000	2,0

ALL DIMENSIONS IN MILLIMETERS.

HARDNESS RANGES: STAINLESS STEEL RINGS (DIN 1.4122 X39CrMo17)

RING TYPE	SIZE RANGE	HARDNESS			
		HV	HRC	15N	30N
DTI	ALL	470-580	47-54	84-87.5	66-72

HARDNESS RANGES: STAINLESS STEEL RINGS (PH 15-7MO)

RING TYPE	SIZE RANGE	HARDNESS			
		VICKERS	ROCKWELL		
			HRC	LOWER SCALE*	
DTI	8-20***	435-530	44-51	82.5-86 HR15N**	
	19.8, 22-50	435-530	44-51	82.5-86 HR15N	

*WHERE APPLICABLE

**HARDNESS CAN NOT BE CHECKED WITH ANY DEGREE OF ACCURACY DIRECTLY ON THESE RINGS.

***EXCLUDING DTI-19.8

HARDNESS RANGES: CARBON STEEL RINGS (SAE 1060-1090)

RING TYPE	SIZE RANGE	HARDNESS			
		VICKERS	ROCKWELL		
			HRC	LOWER SCALE*	
DTI	8-20***	450-520	45-50	83-85.5 HR15N**	
	19.8, 22-50	450-520	45-50	83-85.5 HR15N	

*WHERE APPLICABLE

**HARDNESS CAN NOT BE CHECKED WITH ANY DEGREE OF ACCURACY DIRECTLY ON THESE RINGS.

***EXCLUDING DTI-19.8



MHO Housing Rings

Axially Assembled, Internal, ANSI Metric

Once installed in the groove of a housing/bore, the portion of the ring protruding from the groove (also called a "shoulder") holds an assembly in place.

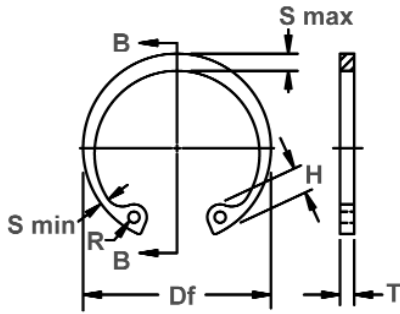

Free Diameter & Ring Measurements With Section B-B

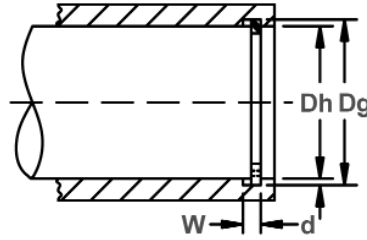

Housing Diameter & Groove Dimensions

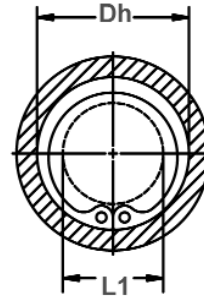

Clearance Diameter Compressed In Housing

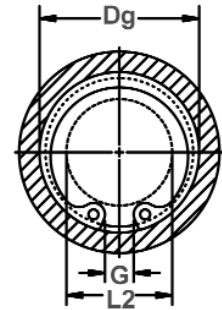

Clearance Diameter & Gap Width Released In Groove

RING NO.	HOUSING DIAMETER		GROOVE SIZE						RING SIZE & WEIGHT				CLEARANCE DIA.			î THRUST LD (kN)	
			DIAMETER			WIDTH		DEPTH	FREE DIAMETER		THICKNESS***		Wt. Per 1000 pcs.	Compressed in housing	Released in Groove	Sqr. corner abutment	
	Ds mm	Ds INCH	Dg	tol	F.I.M.*	W	tol	d	Df	tol	T	tol				kg	L1
MHO-8	8	0.315	8.40	+0.06	0.03	0.50	+0.10	0.20	8.80		0.4		0.05	4.4	4.8	2.4	1.0
MHO-9	9	0.354	9.45		0.03	0.70		0.23	10.00		0.6		0.11	4.6	5.0	4.4	1.2
MHO-10	10	0.393	10.50		0.03	0.70		0.25	11.10		0.6		0.14	5.5	6.0	4.9	1.5
MHO-11	11	0.433	11.60		0.05	0.70		0.30	12.20		0.6		0.17	5.7	6.3	5.4	2.0
MHO-12	12	0.472	12.65		0.05	0.70		0.33	13.30		0.6		0.19	6.7	7.3	5.8	2.4
MHO-13	13	0.512	13.70		0.05	1.00		0.35	14.25	+0.25	0.9		0.35	6.8	7.5	8.9	2.6
MHO-14	14	0.551	14.80	+0.10	0.05	1.00		0.40	15.45	-0.13	0.9		0.39	6.9	7.7	9.7	3.2
MHO-15	15	0.591	15.85		0.05	1.00		0.43	16.60		0.9		0.42	7.9	8.7	10.4	3.7
MHO-16	16	0.630	16.90		0.10	1.00		0.45	17.70		0.9		0.47	8.8	9.7	11.0	4.2
MHO-17	17	0.669	18.00		0.10	1.00		0.50	18.90		0.9		0.52	9.8	10.8	11.7	4.9
MHO-18	18	0.708	19.05		0.10	1.00		0.53	20.05		0.9		0.58	10.3	11.3	12.3	5.5
MHO-19	19	0.748	20.10		0.10	1.00		0.55	21.10		0.9		0.59	11.4	12.5	13.1	6.0
MHO-20	20	0.787	21.15		0.10	1.00		0.57	22.25		0.9		0.70	11.6	12.7	13.7	6.6
MHO-21	21	0.826	22.20		0.10	1.00	+0.15	0.60	23.30		0.9	±0.06	0.82	12.6	13.8	14.5	7.3
MHO-22	22	0.866	23.30		0.10	1.20		0.65	24.40		1.1		0.90	13.5	14.8	22.5	8.3
MHO-23	23	0.905	24.35	+0.15	0.10	1.20		0.67	25.45	+0.40	1.1		1.00	14.5	15.9	23.5	8.9
MHO-24	24	0.945	25.40		0.10	1.20		0.70	26.55	-0.25	1.1		1.09	15.5	16.9	24.8	9.7
MHO-25	25	0.984	26.60		0.10	1.20		0.80	27.75		1.1		1.26	16.5	18.1	25.7	11.6
MHO-26	26	1.023	27.70		0.15	1.20		0.85	28.85		1.1		1.3	17.5	19.2	26.8	12.7
MHO-27	27	1.063	28.80		0.15	1.40		0.90	29.95		1.3		1.7	17.4	19.2	33.0	14.0
MHO-28	28	1.102	29.80		0.15	1.40		0.90	31.10		1.3		1.8	18.2	20.0	34.0	14.6
MHO-30	30	1.181	31.90		0.15	1.40		0.95	33.40		1.3		2.0	20.0	21.9	37.0	16.5
MHO-32	32	1.260	33.90		0.15	1.40		0.95	35.35	+0.65	1.3		2.2	22.0	23.9	39.0	17.6
MHO-34	34	1.339	36.10		0.15	1.40		1.05	37.75	-0.50	1.3		2.3	24.0	26.1	42.0	20.6
MHO-35	35	1.378	37.20	+0.20	0.15	1.40		1.10	38.75		1.3		2.3	25.0	27.2	43.0	22.3
MHO-36	36	1.417	38.30		0.15	1.40		1.15	40.00		1.3		2.6	26.0	28.3	44.0	23.9
MHO-37	37	1.457	39.30		0.15	1.40		1.15	41.05		1.3		2.9	27.0	29.3	45.0	24.6
MHO-38	38	1.496	40.40		0.15	1.40		1.20	42.15		1.3		3.0	28.0	30.4	46.0	26.4

* F.I.M. (FULL INDICATOR MOVEMENT)- MAXIMUM ALLOWABLE DEVIATION OF CONCENTRICITY BETWEEN GROOVE & HOUSING.

î BASED ON HOUSINGS/SHAFTS MADE OF COLD ROLLED STEEL. FOR AN EXPLANATION OF FORMULAS USED TO DERIVE THRUST LOAD AND OTHER PERFORMANCE DATA CONTACT THE ROTOR CLIP ENGINEERING DEPARTMENT.

***FOR PLATED RINGS ADD 0.05 TO THE LISTED MAXIMUM THICKNESS. MAXIMUM THICKNESS WILL BE A MINIMUM OF 0.005 LESS THAN THE LISTED GROOVE WIDTH (W) MINIMUM.

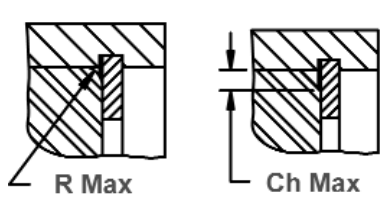

Allowable Corner Radius & Chamfer

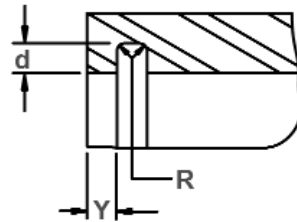

Exploded Groove Profile & Edge Margin (Y)
 Maximum bottom radii (R), 0.10 for ring sizes
 -8 thru -17; 0.2 for ring sizes -18 thru -30;
 0.3 for ring sizes -32 thru -55
 0.4 for ring sizes -56 thru -250

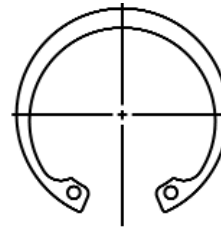

Alternate Lug Design
 For Larger Sizes
 (Manufacturer's Option)

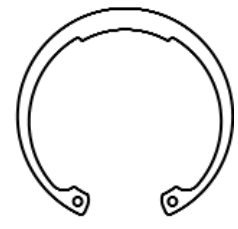

Alternate Design
 (Manufacturer's Option)

RING NO.	LUG HEIGHT	MAXIMUM SECTION	MINIMUM SECTION	HOLE DIAMETER	GAP WIDTH Ring in Groove	ALLOWABLE CORNER RADII & CHAMFERS		MAX. LOAD w/ R max or Ch max	EDGE MARGIN
	H nom	S max/Ref.	S min/Ref.	R min	G	R max	Ch max	P'r	Y
MHO-8	1.7	0.85	0.45	0.8	1.40	0.4	0.3	0.8	0.6
MHO-9	2.1	1.25	0.65	1.0	1.50	0.5	0.35	2.0	0.7
MHO-10	2.1	1.30	0.70	1.0	1.85	0.5	0.35	2.0	0.8
MHO-11	2.5	1.30	0.70	1.0	1.95	0.6	0.4	2.0	0.9
MHO-12	2.5	1.35	0.75	1.0	2.25	0.6	0.4	2.0	1.0
MHO-13	2.9	1.35	0.90	1.2	2.35	0.7	0.5	4.0	1.1
MHO-14	3.3	1.60	0.90	1.2	2.65	0.7	0.5	4.0	1.2
MHO-15	3.3	1.65	0.95	1.5	2.80	0.7	0.5	4.0	1.3
MHO-16	3.4	1.70	0.95	1.5	2.80	0.7	0.5	4.0	1.4
MHO-17	3.4	1.70	0.95	1.5	3.35	0.75	0.6	4.0	1.5
MHO-18	3.6	1.80	1.00	1.5	3.40	0.75	0.6	4.0	1.6
MHO-19	3.6	1.80	1.00	1.5	3.40	0.8	0.65	4.0	1.7
MHO-20	4.0	2.00	1.10	1.5	3.80	0.9	0.7	4.0	1.7
MHO-21	4.0	2.10	1.20	1.5	4.20	0.9	0.7	4.0	1.8
MHO-22	4.0	2.10	1.20	1.5	4.30	0.9	0.7	7.4	1.9
MHO-23	4.0	2.20	1.20	1.5	4.90	1.0	0.8	7.4	2.0
MHO-24	4.0	2.30	1.30	1.5	5.20	1.0	0.8	7.4	2.1
MHO-25	4.0	2.60	1.30	1.5	6.00	1.0	0.8	7.4	2.4
MHO-26	4.0	2.70	1.40	1.5	5.70	1.2	1.0	7.4	2.6
MHO-27	4.6	2.80	1.40	1.9	5.90	1.2	1.0	10.8	2.7
MHO-28	4.6	2.90	1.50	1.9	6.00	1.2	1.0	10.8	2.7
MHO-30	4.6	3.00	1.50	1.9	6.00	1.2	1.0	10.8	2.9
MHO-32	4.6	3.10	1.60	1.9	7.30	1.2	1.0	10.8	2.9
MHO-34	4.6	3.20	1.60	1.9	7.60	1.2	1.0	10.8	3.2
MHO-35	4.6	3.30	1.60	1.9	8.00	1.2	1.0	10.8	3.3
MHO-36	4.6	3.40	1.70	1.9	8.30	1.2	1.0	10.8	3.5
MHO-37	4.6	3.40	1.70	1.9	8.40	1.2	1.0	10.8	3.5
MHO-38	4.6	3.40	1.70	1.9	8.60	1.2	1.0	10.8	3.6

FOR HARDNESS SPECIFICATIONS, SEE END OF THE SECTION.

MHO Housing Rings

Axially Assembled, Internal, ANSI Metric

Once installed in the groove of a housing/bore, the portion of the ring protruding from the groove (also called a "shoulder") holds an assembly in place.

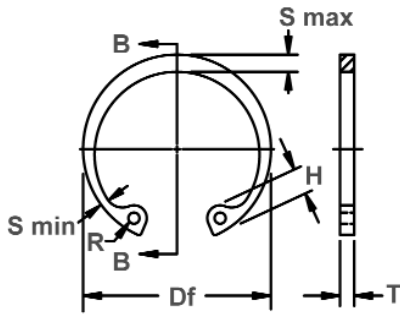

Free Diameter & Ring Measurements With Section B-B

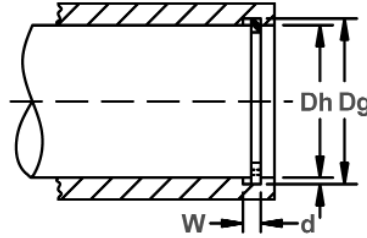

Housing Diameter & Groove Dimensions

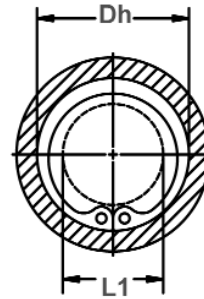

Clearance Diameter Compressed In Housing

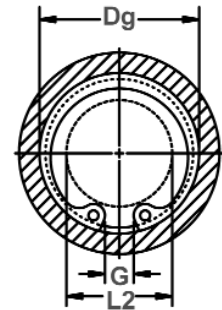

Clearance Diameter & Gap Width Released In Groove

RING NO.	HOUSING DIAMETER		GROOVE SIZE					RING SIZE & WEIGHT				CLEARANCE DIA.			THRUST LD (kN)		
			DIAMETER		WIDTH		DEPTH	FREE DIAMETER		THICKNESS***	Wt. Per 1000 pcs.	Compressed in housing	Released in Groove	Sqr. corner abutment			
	Ds mm	Ds INCH	Dg	tol	F.I.M.*	W	tol	d	Df	tol	T	tol	kg	L1	L2	Pr	Pg
MHO-40	40	1.575	42.40	+0.20	0.15	1.75	+0.20	1.20	44.25	-0.65	1.6	±0.08	4.0	29.2	31.6	62.0	27.7
MHO-42	42	1.654	44.50		0.15	1.75		1.25	46.60		1.6		4.7	29.7	32.2	65.0	30.2
MHO-45	45	1.772	47.60		0.15	1.75		1.30	49.95		1.6		5.1	32.3	34.9	69.0	33.8
MHO-46	46	1.811	48.70		0.20	1.75		1.35	51.05		1.6		5.2	33.3	36.0	71.0	36.0
MHO-47	47	1.850	49.80		0.20	1.75		1.40	52.15		1.6		5.8	34.3	37.1	72.0	38.0
MHO-48	48	1.890	50.90		0.20	1.75		1.45	53.30		1.6		6.1	35.0	37.9	74.0	40.0
MHO-50	50	1.969	53.10		0.20	1.75		1.55	55.35		1.6		6.2	36.9	40.0	77.0	45.0
MHO-52	52	2.047	55.30		0.20	2.15		1.65	57.90		2.0		8.1	38.6	41.9	99.0	50.0
MHO-55	55	2.165	58.40		0.20	2.15		1.70	61.10		2.0		8.9	40.8	44.2	105.0	54.0
MHO-57	57	2.244	60.50		0.20	2.15		1.75	63.25		2.0		9.9	42.2	45.7	109.0	58.0
MHO-58	58	2.283	61.60	0.20	2.15	1.80	64.40	2.0	10.1	43.2	46.8	111.0	60.0				
MHO-60	60	2.362	63.80	0.20	2.15	1.90	66.80	2.0	±0.08	10.5	45.5	49.3	115.0	66.0			
MHO-62	62	2.441	65.80	0.20	2.15	1.90	68.60	+1.00	2.0	11.5	47.0	50.8	119.0	68.0			
MHO-63	63	2.480	66.90	0.20	2.15	1.95	69.90	-0.75	2.0	11.6	47.8	51.7	120.0	71.0			
MHO-65	65	2.559	69.00	0.20	2.55	2.00	72.20	2.4	15.4	49.4	53.4	149.0	75.0				
MHO-68	68	2.677	72.20	+0.30	0.20	2.55	+0.20	2.10	75.70	2.4	15.9	52.0	56.2	156.0	82.0		
MHO-70	70	2.756	74.40	0.20	2.55	2.20	77.50	2.4	16.1	53.8	58.2	161.0	88.0				
MHO-72	72	2.835	76.50	0.20	2.55	2.25	79.60	2.4	16.3	55.9	60.4	166.0	93.0				
MHO-75	75	2.953	79.70	0.20	2.55	2.35	83.30	2.4	19.3	58.2	62.9	172.0	101.0				
MHO-78	78	3.071	82.80	0.20	2.95	2.40	86.80	2.8	24.0	61.2	66.0	209.0	108.0				
MHO-80	80	3.150	85.00	0.20	2.95	2.50	89.10	2.8	25.9	63.0	68.0	215.0	115.0				
MHO-82	82	3.228	87.20	0.25	2.95	2.60	91.10	+1.40	2.8	27.2	63.5	68.7	220.0	122.0			
MHO-85	85	3.346	90.40	0.25	2.95	2.70	94.40	-1.40	2.8	29.5	66.8	72.2	228.0	131.0			
MHO-88	88	3.464	93.60	0.25	2.95	2.80	97.90	2.8	31.3	69.6	75.2	236.0	141.0				
MHO-90	90	3.543	95.70	0.25	2.95	2.85	100.00	2.8	32.6	71.6	77.3	241.0	147.0				
MHO-92	92	3.622	97.80	0.25	2.95	2.90	102.20	2.8	33.1	73.6	79.4	247.0	153.0				

* F.I.M. (FULL INDICATOR MOVEMENT)- MAXIMUM ALLOWABLE DEVIATION OF CONCENTRICITY BETWEEN GROOVE & HOUSING.

† BASED ON HOUSINGS/SHAFTS MADE OF COLD ROLLED STEEL. FOR AN EXPLANATION OF FORMULAS USED TO DERIVE THRUST LOAD AND OTHER PERFORMANCE DATA CONTACT THE ROTOR CLIP ENGINEERING DEPARTMENT.

***FOR PLATED RINGS ADD 0.05 TO THE LISTED MAXIMUM THICKNESS. MAXIMUM THICKNESS WILL BE A MINIMUM OF 0.005 LESS THAN THE LISTED GROOVE WIDTH (W) MINIMUM.

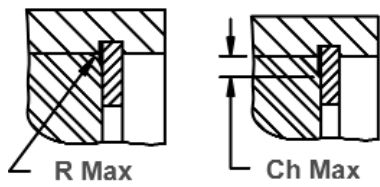

Allowable Corner Radius & Chamfer

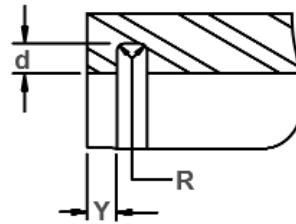

Exploded Groove Profile & Edge Margin (Y)
 Maximum bottom radii (R), 0.10 for ring sizes
 -8 thru -17; 0.2 for ring sizes -18 thru -30;
 0.3 for ring sizes -32 thru -55
 0.4 for ring sizes -56 thru -250

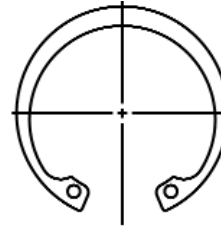

Alternate Lug Design
 For Larger Sizes
 (Manufacturer's Option)

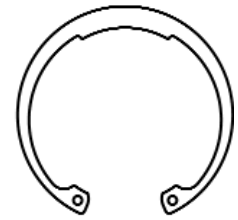

Alternate Design
 (Manufacturer's Option)

RING NO.	LUG HEIGHT	MAXIMUM SECTION	MINIMUM SECTION	HOLE DIAMETER	GAP WIDTH Ring in Groove	ALLOWABLE CORNER RADII & CHAMFERS		MAX. LOAD w/ R max or Ch max	EDGE MARGIN
	H nom	S max/Ref.	S min/Ref.	R min	G	R max	Ch max	P'r	Y
MHO-40	5.1	4.00	2.00	1.9	9.70	1.7	1.3	17.4	3.6
MHO-42	5.8	4.20	2.10	1.9	9.00	1.7	1.3	17.4	3.7
MHO-45	6.0	4.30	2.10	1.9	9.60	1.7	1.3	17.4	3.9
MHO-46	6.0	4.30	2.10	2.3	9.70	1.7	1.3	17.4	4.0
MHO-47	6.0	4.30	2.20	2.3	10.00	1.7	1.3	17.4	4.2
MHO-48	6.0	4.50	2.30	2.3	10.50	1.7	1.3	17.4	4.3
MHO-50	6.0	4.60	2.30	2.3	12.10	1.7	1.3	17.4	4.6
MHO-52	6.4	4.70	2.30	2.3	11.70	2.0	1.6	27.4	5.0
MHO-55	6.7	5.10	2.50	2.3	11.90	2.0	1.6	27.4	5.1
MHO-57	6.9	5.20	2.50	2.3	12.50	2.0	1.6	27.4	5.3
MHO-58	6.9	5.30	2.60	2.3	13.00	2.0	1.6	27.4	5.4
MHO-60	6.9	5.30	2.60	2.3	12.70	2.0	1.6	27.4	5.7
MHO-62	7.1	5.30	2.60	2.7	14.00	2.0	1.6	27.4	5.7
MHO-63	7.1	5.40	2.70	2.7	14.20	2.0	1.6	27.4	5.9
MHO-65	7.4	5.60	2.80	2.7	14.20	2.0	1.6	42.0	6.0
MHO-68	7.6	5.80	2.90	2.7	14.40	2.3	1.8	39.0	6.3
MHO-70	7.6	5.80	2.90	2.7	16.10	2.3	1.8	39.0	6.6
MHO-72	7.6	5.80	2.90	2.7	17.40	2.3	1.8	39.0	6.7
MHO-75	7.9	6.20	3.10	2.7	16.80	2.3	1.8	54.0	7.1
MHO-78	7.9	6.50	3.20	3.1	17.60	2.5	2.0	54.0	7.2
MHO-80	7.9	6.70	3.30	3.1	17.20	2.5	2.0	54.0	7.5
MHO-82	8.7	6.90	3.40	3.1	18.80	2.6	2.1	54.0	7.8
MHO-85	8.7	7.00	3.60	3.1	19.10	2.6	2.1	54.0	8.1
MHO-88	8.7	7.30	3.60	3.1	20.40	2.8	2.2	54.0	8.4
MHO-90	8.7	7.40	3.60	3.1	21.40	2.8	2.2	54.0	8.6
MHO-92	8.7	7.60	3.80	3.1	22.20	2.9	2.4	54.0	8.7

FOR HARDNESS SPECIFICATIONS, SEE END OF THE SECTION.

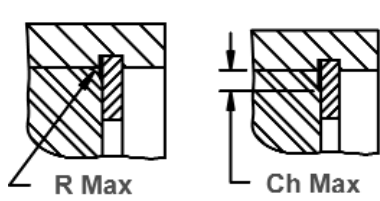

Allowable Corner Radius & Chamfer

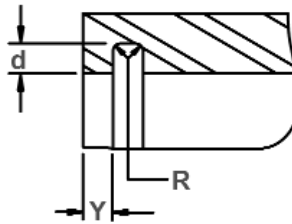

Exploded Groove Profile & Edge Margin (Y)
 Maximum bottom radii (R), 0.10 for ring sizes
 -8 thru -17; 0.2 for ring sizes -18 thru -30;
 0.3 for ring sizes -32 thru -55
 0.4 for ring sizes -56 thru -250

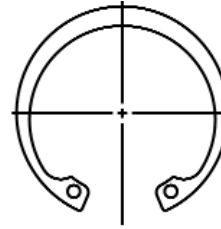

Alternate Lug Design
 For Larger Sizes
 (Manufacturer's Option)

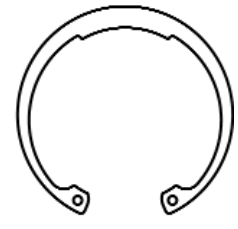

Alternate Design
 (Manufacturer's Option)

RING NO.	LUG HEIGHT	MAXIMUM SECTION	MINIMUM SECTION	HOLE DIAMETER	GAP WIDTH Ring in Groove	ALLOWABLE CORNER RADII & CHAMFERS		MAX. LOAD w/ R max or Ch max	EDGE MARGIN
						R max	Ch max		
	H nom	S max/Ref.	S min/Ref.	R min	G			P'r	Y
MHO-95	8.7	7.80	3.90	3.1	22.60	3.0	2.5	54.0	9.0
MHO-98	9.4	8.10	4.10	3.1	22.60	3.0	2.5	54.0	9.3
MHO-100	9.4	8.20	4.10	3.1	24.10	3.1	2.5	54.0	9.5
MHO-102	9.4	8.40	4.20	3.1	25.50	3.2	2.6	54.0	9.6
MHO-105	9.4	8.40	4.30	3.1	26.00	3.3	2.6	54.0	9.8
MHO-108	9.4	8.50	4.60	3.1	26.40	3.5	2.7	54.0	9.9
MHO-110	10.3	8.70	4.60	3.8	27.50	3.6	2.8	54.0	10.1
MHO-115	10.3	8.90	4.60	3.8	29.40	3.7	2.9	54.0	10.4
MHO-120	10.3	9.40	4.60	3.8	27.20	3.9	3.1	54.0	10.5
MHO-125	10.3	9.50	4.70	3.8	30.30	4.0	3.2	54.0	10.7
MHO-130	10.3	9.80	4.90	3.8	31.00	4.0	3.2	54.0	10.8
MHO-135	11.6	10.40	5.00	3.8	30.40	4.3	3.4	67.0	11.0
MHO-140	11.6	10.40	5.00	3.8	30.40	4.3	3.4	67.0	11.1
MHO-145	11.6	10.60	5.30	3.8	31.60	4.3	3.4	67.0	11.3
MHO-150	11.6	10.80	5.40	3.8	33.50	4.3	3.4	67.0	11.4
MHO-155	11.6	10.80	5.40	3.8	37.00	4.3	3.4	67.0	11.6
MHO-160	12.3	10.90	5.40	4.6	35.00	4.5	3.6	102.0	11.7
MHO-165	12.3	11.10	5.60	4.6	33.10	4.6	3.7	102.0	11.9
MHO-170	12.3	11.40	5.60	4.6	38.20	4.6	3.7	102.0	12.0
MHO-175	13.5	11.60	5.70	4.6	37.70	4.8	3.8	102.0	12.3
MHO-180	13.5	12.00	5.90	4.6	39.00	5.0	4.0	102.0	12.6
MHO-185	14.2	12.40	6.00	4.6	37.30	5.1	4.1	151.0	12.9
MHO-190	14.2	12.90	6.30	4.6	35.00	5.3	4.3	151.0	13.2
MHO-200	14.2	13.30	6.50	4.6	43.90	5.4	4.3	151.0	13.5
MHO-210	15.2	14.20	6.90	4.6	40.60	5.8	4.6	151.0	14.1
MHO-220	16.8	15.00	7.30	4.6	38.30	6.1	4.9	151.0	15.0
MHO-230	16.8	15.50	7.50	4.6	49.00	6.3	5.1	151.0	15.9
MHO-240	18.7	16.30	7.70	4.6	45.40	6.6	5.3	151.0	16.5
MHO-250	18.7	16.70	7.80	4.6	53.00	6.7	5.4	151.0	17.1

HARDNESS RANGES: STAINLESS STEEL RINGS (PH 15-7MO)

RING TYPE	SIZE RANGE	SCALE	ROCKWELL HARDNESS
MHO	8	15N	82.5-86
	9-26	30N	63-69.5
	27-250	C	44-51

HARDNESS RANGES: CARBON STEEL RINGS (SAE 1060-1090)

RING TYPE	SIZE RANGE	SCALE	ROCKWELL HARDNESS
MHO	8	15N	86-88
	9-13	30N	69.5-73
	14-20	30N	68.5-72
	21-26	30N	67.5-71
	27-250	C	48-52



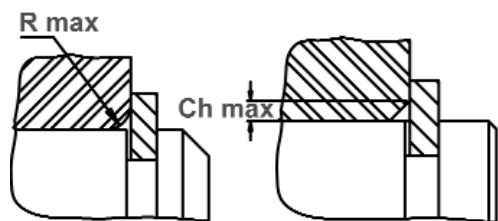

Allowable Corner Radius & Chamfer

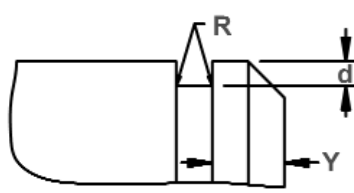

Exploded Groove Profile & Edge Margin (Y)
 Maximum bottom radii (R), 0.10 for ring sizes
 -7 thru -18; 0.2 for ring sizes -19 thru -30;
 0.3 for ring sizes -32 thru -50
 0.4 for ring sizes -52 thru -100



Alternate Lug Design
 For Sizes
 MSH-4 Thru MSH-6

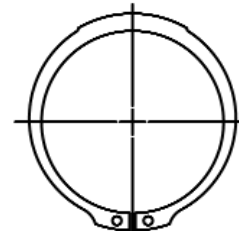

Alternate Design
 (Manufacturer's Option)

RING NO.	LUG HEIGHT	MAXIMUM SECTION	MINIMUM SECTION	HOLE DIAMETER	GAGING DIA.	ALLOWABLE CORNER RADII & CHAMFERS		MAX. LOAD w/ R max or Ch max (kN)	EDGE MARGIN	R.P.M. LIMITS Standard Material
	H nom	S max/Ref.	S min/Ref.	R min	Gd	R max	Ch max	P'r	Y	RPM
MSH-4*	1.35	0.65	0.40	0.6	4.90	0.35	0.25	0.2	0.3	70000
MSH-5*	1.40	0.65	0.40	0.6	5.85	0.35	0.25	0.5	0.4	70000
MSH-6*	1.40	0.75	0.50	0.6	6.95	0.35	0.25	0.5	0.5	70000
MSH-7	2.05	0.90	0.60	1.0	8.05	0.45	0.3	2.1	0.6	60000
MSH-8	2.20	1.00	0.65	1.0	9.15	0.5	0.35	2.1	0.8	55000
MSH-9	2.20	1.15	0.75	1.0	10.35	0.6	0.35	2.1	0.8	48000
MSH-10	2.20	1.30	0.80	1.0	11.50	0.7	0.4	2.1	0.9	42000
MSH-11	2.20	1.40	0.85	1.0	12.60	0.75	0.45	2.1	1.0	38000
MSH-12	2.20	1.50	0.90	1.0	13.80	0.8	0.45	2.1	1.0	34000
MSH-13	2.80	1.60	0.95	1.2	15.05	0.8	0.5	4.0	1.0	31000
MSH-14	2.80	1.70	1.00	1.2	15.60	0.9	0.5	4.0	1.2	28000
MSH-15	2.80	1.80	1.05	1.2	17.20	1.0	0.6	4.0	1.3	27000
MSH-16	2.80	2.05	1.15	1.2	18.35	1.1	0.6	4.0	1.4	25000
MSH-17	2.80	2.10	1.15	1.2	19.35	1.1	0.6	4.0	1.4	24000
MSH-18	3.45	2.25	1.25	1.3	20.60	1.2	0.7	6.0	1.5	23000
MSH-19	3.45	2.35	1.30	1.3	21.70	1.2	0.7	6.0	1.6	21500
MSH-20	3.45	2.40	1.35	1.3	22.65	1.2	0.7	6.0	1.7	20000
MSH-21	3.45	2.50	1.40	1.3	23.80	1.3	0.7	6.0	1.8	19000
MSH-22	3.45	2.70	1.50	1.3	24.90	1.3	0.8	6.0	1.9	18500
MSH-23	3.45	2.80	1.60	1.3	26.00	1.3	0.8	6.0	2.0	18000
MSH-24	4.20	2.90	1.60	1.9	27.15	1.4	0.8	6.0	2.1	17500
MSH-25	4.20	2.90	1.70	1.9	28.10	1.4	0.8	6.0	2.3	17000
MSH-26	4.20	3.00	1.70	1.9	29.25	1.5	0.9	6.0	2.3	16500
MSH-27	4.60	3.10	1.80	1.9	30.35	1.5	0.9	8.6	2.3	16300
MSH-28	4.60	3.20	1.80	1.9	31.45	1.6	1.0	8.6	2.4	15800
MSH-30	4.60	3.30	1.80	1.9	33.60	1.6	1.0	8.6	2.5	15000
MSH-32	4.60	3.60	1.90	1.9	35.90	1.7	1.0	8.6	2.7	14800
MSH-34	4.60	3.80	2.00	1.9	37.90	1.7	1.1	8.6	3.0	14000
MSH-35	4.60	3.90	2.10	1.9	39.00	1.8	1.1	8.6	3.1	13500
MSH-36	5.40	4.10	2.20	1.9	40.20	1.9	1.2	8.6	3.2	13300
MSH-38	5.40	4.30	2.30	3.1	42.50	2.0	1.2	8.6	3.3	12700
MSH-40	6.00	4.40	2.30	3.1	44.50	2.1	1.2	13.2	3.4	12000
MSH-42	6.00	4.60	2.40	3.1	46.90	2.2	1.3	13.2	3.6	11000
MSH-43	6.00	4.70	2.50	3.1	47.90	2.3	1.4	13.2	3.8	10800
MSH-45	6.00	4.80	2.60	3.1	50.00	2.3	1.4	13.2	3.9	10000
MSH-46	6.00	4.90	2.60	3.1	50.90	2.4	1.4	13.2	4.0	9500
MSH-48	6.20	5.00	2.60	3.1	53.00	2.4	1.4	13.2	4.2	8800
MSH-50	6.20	5.10	2.70	3.1	55.20	2.4	1.4	13.2	4.2	8000

FOR HARDNESS SPECIFICATIONS SEE END OF THE SECTION.



MSH Shaft Rings

Axially Assembled, External, ANSI Metric

Once installed in the groove of a shaft, the portion of the ring protruding from the groove (also called a "shoulder") holds an assembly in place.

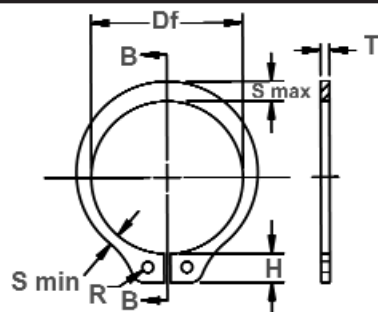

Free Diameter & Ring Measurements with Section B-B

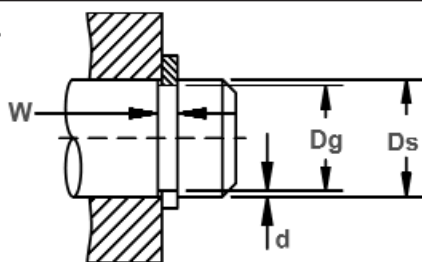

Shaft Diameter & Groove Dimensions

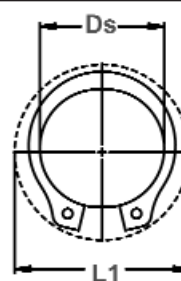

Clearance Diameter Expanded Over Shaft



Clearance Diameter & Gaging Diameter Released in Groove.

RING NO.	SHAFT DIAMETER		GROOVE SIZE						RING SIZE & WEIGHT				CLEARANCE DIA.			THRUST LD (kN)	
			DIAMETER			WIDTH		DEPTH	FREE DIAMETER		THICKNESS ***		Wt. Per 1000 pcs.	Ex-panded over Shaft	Re-leased in Groove	Sqr. corner abutment	
	Ds mm	Ds INCH	Dg	tol	F.I.M.**	W	tol	d	Df	tol	T	tol				kg	L1
MSH-54	54	2.126	51.00	-0.30	0.15	2.15		1.50	49.90		2.00		11.8	69.6	66.1	87.0	40.0
MSH-55	55	2.165	51.80		0.15	2.15		1.60	50.60		2.00		11.9	70.6	66.9	89.0	44.0
MSH-57	57	2.244	53.80		0.20	2.15		1.60	52.90	+0.35	2.00		12.5	72.6	68.9	91.0	45.0
MSH-58	58	2.283	54.70		0.20	2.15		1.65	53.60	-0.65	2.00		12.6	73.6	69.8	93.0	46.0
MSH-60	60	2.362	56.70		0.20	2.15		1.65	55.80		2.00		13.2	75.6	71.8	97.0	49.0
MSH-62	62	2.441	58.60		0.20	2.15		1.70	57.30		2.00		13.4	77.6	73.6	100.0	52.0
MSH-65	65	2.559	61.60		0.20	2.15		1.70	60.40		2.00		15.4	80.6	76.6	105.0	54.0
MSH-68	68	2.677	64.50		0.20	2.15		1.75	63.10		2.00		16.3	83.6	79.5	110.0	58.0
MSH-70	70	2.756	66.40		0.20	2.55	+0.20	1.80	64.60		2.40	±0.08	19.3	88.1	83.9	136.0	62.0
MSH-72	72	2.835	68.30	-0.40	0.20	2.55		1.85	66.60		2.40		20.6	90.1	85.8	140.0	65.0
MSH-75	75	2.953	71.20		0.20	2.55		1.90	69.00		2.40		22.6	93.1	88.7	147.0	69.0
MSH-78	78	3.071	74.00		0.20	2.55		2.00	72.00	+0.50	2.40		21.5	95.4	92.1	151.0	76.0
MSH-80	80	3.150	75.90		0.20	2.55		2.05	74.20	-0.75	2.40		26.8	97.9	93.1	155.0	80.0
MSH-82	82	3.228	77.80		0.20	2.55		2.10	76.40		2.40		28.1	100.0	95.1	159.0	84.0
MSH-85	85	3.346	80.60		0.20	2.55		2.20	78.60		2.40		29.0	103.0	97.9	165.0	91.0
MSH-88	88	3.464	83.50		0.20	2.95		2.25	81.40		2.80		32.2	107.0	100.8	199.0	97.0
MSH-90	90	3.543	85.40		0.20	2.95		2.30	83.20		2.80		33.1	109.0	103.6	204.0	101.0
MSH-95	95	3.740	90.20		0.20	2.95		2.40	88.10		2.80		37.6	114.0	108.6	215.0	112.0
MSH-100	100	3.852	95.20		0.20	2.95		2.42	92.50		2.80		43.1	119.5	113.7	227.0	123.0

** F.I.M. (FULL INDICATOR MOVEMENT)- MAXIMUM ALLOWABLE DEVIATION OF CONCENTRICITY BETWEEN GROOVE & SHAFT.

† BASED ON HOUSINGS/SHAFTS MADE OF COLD ROLLED STEEL.

FOR AN EXPLANATION OF FORMULAS USED TO DERIVE THRUST LOAD AND OTHER PERFORMANCE DATA CONTACT THE ROTOR CLIP ENGINEERING DEPARTMENT.

***FOR PLATED RINGS ADD 0.05 TO THE LISTED MAXIMUM THICKNESS (T) AND BEVELED END THICKNESS (U) VALUES.

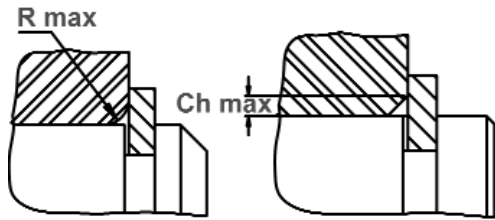

Allowable Corner Radius & Chamfer

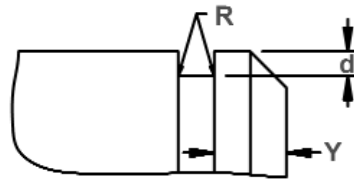

Exploded Groove Profile & Edge Margin (Y)
 Maximum bottom radii (R), 0.10 for ring sizes
 -7 thru -18; 0.2 for ring sizes -19 thru -30;
 0.3 for ring sizes -32 thru -50
 0.4 for ring sizes -52 thru -100

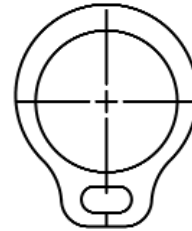

Alternate Lug Design
 For Sizes
 MSH-4 Thru MSH-6

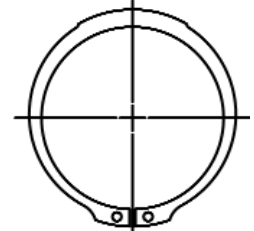

Alternate Design
 (Manufacturer's Option)

RING NO.	LUG HEIGHT	MAXIMUM SECTION	MINIMUM SECTION	HOLE DIAMETER	GAGING DIA.	ALLOWABLE CORNER RADII & CHAMFERS		MAX. LOAD w/ R max or Ch max (kN)	EDGE MARGIN	R.P.M. LIMITS Standard Material
						R max	Ch max			
	H nom	S max/Ref.	S min/Ref.	R min	Gd			P'r	Y	RPM
MSH-54	6.80	5.40	2.90	3.1	59.50	2.5	1.5	22.0	4.5	7500
MSH-55	6.80	5.40	2.90	3.1	60.40	2.5	1.5	22.0	4.8	7400
MSH-57	6.80	5.60	3.00	3.1	62.70	2.6	1.5	22.0	4.8	7200
MSH-58	6.80	5.60	3.00	3.1	63.60	2.6	1.6	22.0	4.9	7100
MSH-60	6.80	5.70	3.00	3.1	65.80	2.6	1.6	22.0	4.9	7000
MSH-62	6.80	5.80	3.00	3.1	67.90	2.7	1.6	22.0	5.1	6900
MSH-65	6.80	6.00	3.10	3.1	71.20	2.8	1.7	22.0	5.1	6700
MSH-68	6.80	6.20	3.30	3.1	74.50	2.9	1.7	22.0	5.3	6500
MSH-70	7.80	6.30	3.30	3.1	76.40	2.9	1.7	32.0	5.4	6400
MSH-72	7.80	6.40	3.30	3.1	78.50	2.9	1.7	32.0	5.5	6200
MSH-75	7.80	6.60	3.40	3.1	81.70	3.0	1.8	32.0	5.7	5900
MSH-78	7.80	6.60	3.40	3.1	84.60	3.0	1.8	32.0	6.0	5600
MSH-80	7.80	7.00	3.60	3.1	87.00	3.1	1.9	32.0	6.1	5400
MSH-82	7.80	7.10	3.70	3.1	89.00	3.2	1.9	32.0	6.3	5200
MSH-85	7.80	7.30	3.80	3.1	92.10	3.2	1.9	32.0	6.6	5000
MSH-88	8.40	7.50	3.90	3.1	95.10	3.2	1.9	47.0	6.7	4800
MSH-90	8.40	7.50	3.90	3.1	97.10	3.2	1.9	47.0	6.9	4500
MSH-95	8.40	7.90	4.10	3.1	102.70	3.4	2.1	47.0	7.2	4350
MSH-100	8.70	8.00	4.10	3.1	108.00	3.5	2.1	47.0	7.5	4150

HARDNESS RANGES: STAINLESS STEEL RINGS (PH 15-7MO)

RING TYPE	SIZE RANGE	SCALE	ROCKWELL HARDNESS
MSH	7-21	30N	63-69.5
	22-100	C	44-51

HARDNESS RANGES: CARBON STEEL RINGS (SAE 1060-1090)

RING TYPE	SIZE RANGE	SCALE	ROCKWELL HARDNESS
MSH	7-12	30N	69.5-73
	13-21	30N	67.5-71
	22-26	C	49-53
	27-85	C	48-52
	88-100	C	47-51





MSR Shaft Rings

Axially Assembled, External Reinforced, ANSI Metric

The MSR is an extra thick version of a regular MSH retaining ring. As such, it is stronger and can withstand greater thrust loads than its standard counterpart.

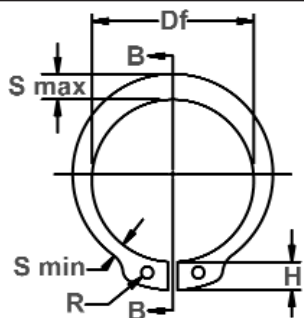

Free Diameter & Ring Measurements
With Section B-B

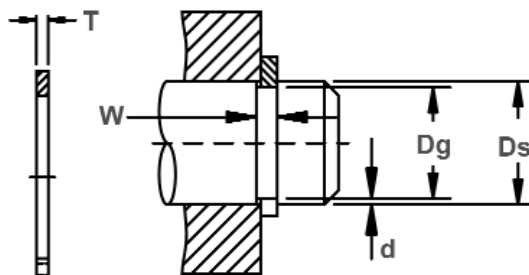

Shaft Diameter &
Groove Dimensions

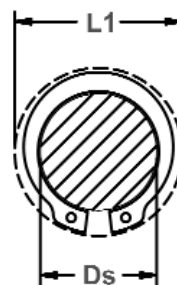

Clearance Diameter
Expanded Over Shaft

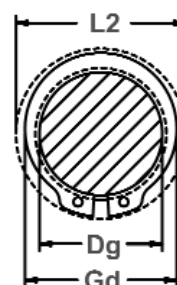

Clearance Diameter &
Gaging Diameter Released
In Groove

RING NO.	SHAFT DIAMETER		GROOVE SIZE						RING SIZE & WEIGHT				CLEARANCE DIA.			i THRUST LD (kN.)	
			DIAMETER		WIDTH		DEPTH	FREE DIAMETER		THICKNESS***		Wt. Per 1000 pcs.	Ex-panded over Shaft	Re-leased in Groove	Sqr. corner abutment		
	Ds mm	Ds INCH	Dg	tol	F.I.M.*	W	tol	d	Df	tol	T				tol	kg	L1
MSR-10	10	0.393	9.40		0.05	1.00		0.30	9.20	+0.08	0.9		0.32	15.6	14.8	9.3	2.9
MSR-11	11	0.433	10.30	-0.08	0.05	1.00		0.35	10.00	-0.20	0.9		0.39	16.6	15.8	10.8	3.8
MSR-12	12	0.472	11.30		0.05	1.20		0.35	11.05		1.1		0.63	17.6	16.8	13.7	4.0
MSR-13	13	0.512	12.20		0.05	1.40		0.40	11.80		1.3	±0.06	0.72	19.5	18.5	17.6	5.0
MSR-14	14	0.551	13.15		0.05	1.40	+0.15	0.43	12.80		1.3		0.80	20.5	19.5	18.9	5.8
MSR-15	15	0.591	14.10		0.05	1.40		0.45	13.80		1.3		1.00	22.1	21.1	20.3	6.5
MSR-16	16	0.630	15.00		0.08	1.40		0.50	14.70	+0.13	1.3		1.04	23.2	22.0	21.6	7.7
MSR-17	17	0.669	15.95	-0.10	0.08	1.40		0.53	15.65	-0.25	1.3		1.2	24.2	22.9	23.0	8.7
MSR-18	18	0.708	16.85		0.08	1.75		0.58	16.55		1.6		1.9	26.8	25.5	30.0	10.0
MSR-19	19	0.748	17.80		0.08	2.15		0.60	17.50		2.0		2.5	28.8	27.4	40.0	11.0
MSR-20	20	0.787	18.75		0.08	2.15		0.63	18.45		2.0		2.8	29.8	28.4	42.0	13.1
MSR-22	22	0.866	20.70		0.08	2.15		0.65	20.40		2.0		3.4	31.9	30.4	46.0	13.7
MSR-25	25	0.984	23.50		0.08	2.15		0.75	23.10		2.0		3.5	34.9	33.1	52.0	18.0
MSR-27	27	1.063	25.40		0.10	2.55		0.80	24.85		2.4		5.2	39.0	37.1	67.0	20.8
MSR-28	28	1.102	26.30		0.10	2.55		0.85	25.70		2.4	±0.08	5.6	40.0	38.0	69.0	22.8
MSR-30	30	1.181	28.20	-0.15	0.10	2.55	+0.20	0.90	27.60	+0.25	2.4		6.1	42.0	40.0	74.0	26.0
MSR-32	32	1.260	30.00		0.10	2.55		1.00	29.35	-0.40	2.4		6.8	44.1	41.8	79.0	30.8
MSR-35	35	1.378	32.80		0.10	2.55		1.10	32.20		2.4		8.1	47.1	44.6	87.0	38.0
MSR-38	38	1.496	35.60		0.10	2.95		1.20	35.05		2.8		12.2	53.2	50.5	111.0	44.0
MSR-40	40	1.575	37.50		0.15	2.95		1.25	36.70	+0.35	2.8		14.1	55.2	52.4	116.0	48.0
MSR-45	45	1.772	42.20	-0.20	0.15	2.95		1.40	41.10	-0.50	2.8		15.1	60.9	57.7	130.0	61.0
MSR-50	50	1.969	47.00		0.15	3.40	+0.25	1.50	45.50		3.2	±0.10	21.8	67.1	63.8	165.0	72.0

* F.I.M.(FULL INDICATOR MOVEMENT)-MAXIMUM ALLOWABLE DEVIATION OF CONCENTRICITY BETWEEN GROOVE AND SHAFT.

i BASED ON HOUSINGS/SHAFTS MADE OF COLD ROLLED STEEL. FOR AN EXPLANATION OF FORMULAS USED TO DERIVE THRUST LOAD AND OTHER PERFORMANCE DATA, CONTACT THE ROTOR CLIP ENGINEERING DEPARTMENT.

*** FOR PLATED RINGS, ADD 0.05 TO THE LISTED MAXIMUM THICKNESS. MAXIMUM RING THICKNESS WILL BE A MINIMUM OF 0.005 LESS THAN THE LISTED GROOVE WIDTH (W) MINIMUM.

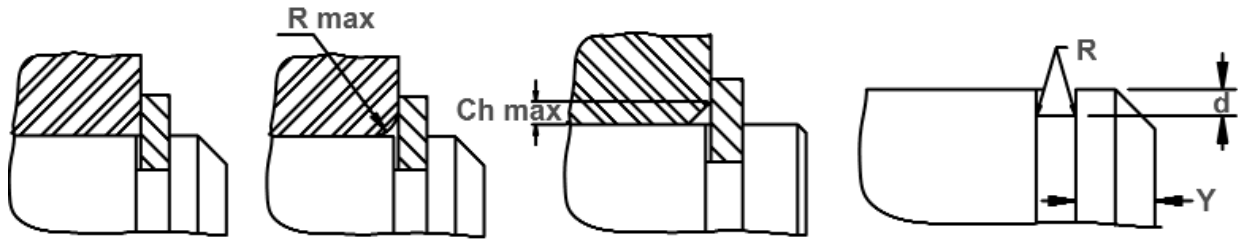

Square Corner Abutment

Allowable Corner Radius & Chamfer

Exploded Groove Profile & Edge Margin (Y)
 Maximum bottom radii (R), 0.10 for ring sizes -10 thru -15; 0.15 for ring sizes -16 thru -20; 0.20 for ring sizes -22 thru -30 0.30 for ring sizes -32 thru -50

RING NO.	LUG HEIGHT	MAXIMUM SECTION	MINIMUM SECTION	HOLE DIAMETER	GAGING DIA.	ALLOWABLE CORNER RADII & CHAMFERS		MAX. LOAD w/ R max or Ch max (kN)	EDGE MARGIN	R.P.M. LIMITS Standard Material
	H nom	S max	S min	R min	Gd	R max	Ch max	P'r	Y	RPM
MSR-10	2.6	1.7	1.0	1.0	12.15	1.0	0.8	2.7	0.9	66000
MSR-11	2.6	1.9	1.1	1.0	13.40	1.0	0.8	3.0	1.0	60000
MSR-12	2.6	2.2	1.3	1.0	14.95	1.6	1.3	3.2	1.0	55000
MSR-13	3.0	2.3	1.3	1.2	15.80	1.6	1.3	4.6	1.2	52000
MSR-14	3.0	2.4	1.4	1.2	16.90	1.6	1.3	4.8	1.3	47000
MSR-15	3.3	2.6	1.4	1.2	18.20	1.6	1.3	5.2	1.3	42000
MSR-16	3.3	2.7	1.5	1.2	19.20	1.6	1.3	5.4	1.5	39000
MSR-17	3.3	2.8	1.6	1.2	20.45	1.6	1.3	5.7	1.6	36000
MSR-18	4.1	3.0	1.8	1.9	21.75	1.8	1.5	8.0	1.7	35000
MSR-19	4.6	3.2	2.0	1.9	23.05	1.8	1.5	13.2	1.8	30000
MSR-20	4.6	3.4	2.0	1.9	24.30	2.0	1.6	13.2	1.9	29000
MSR-22	4.6	3.8	2.1	1.9	26.60	2.0	1.6	14.7	2.0	27000
MSR-25	4.6	3.8	2.1	1.9	29.45	2.0	1.6	14.7	2.2	24000
MSR-27	5.6	4.1	2.3	2.3	32.00	2.0	1.6	22.9	2.4	22000
MSR-28	5.6	4.3	2.4	2.3	33.20	2.0	1.6	24.0	2.5	20000
MSR-30	5.6	4.5	2.5	2.3	35.40	2.0	1.6	25.0	2.7	19000
MSR-32	5.6	4.7	2.6	2.3	37.30	2.5	2.1	19.0	3.0	18000
MSR-35	5.6	5.1	2.8	2.3	40.80	2.5	2.1	22.0	3.3	16000
MSR-38	7.1	5.5	3.1	2.7	44.40	2.5	2.1	32.0	3.6	15000
MSR-40	7.1	5.8	3.2	2.7	46.70	2.5	2.1	34.0	3.7	13500
MSR-45	7.4	6.5	3.6	2.7	52.20	2.5	2.1	38.0	4.2	12500
MSR-50	8.0	7.1	3.9	3.1	58.40	3.5	2.9	39.0	4.5	11000

LARGER SIZES MAY BE AVAILABLE UPON REQUEST.

HARDNESS RANGES: STAINLESS STEEL RINGS (PH 15-7MO)

RING TYPE	SIZE RANGE	SCALE	ROCKWELL HARDNESS
MSR	10-16	30N	63-69.5
	17-50	C	44-51

HARDNESS RANGES: CARBON STEEL RINGS (SAE 1060-1090)

RING TYPE	SIZE RANGE	SCALE	ROCKWELL HARDNESS
MSR	10-16	30N	68.5-72
	17-50	C	48-52



Perhaps the most popular and widely used radial retaining ring is the "E" (so named because it is shaped like the letter "E").

Three prongs make contact with the bottom of the groove and provide a shoulder for effective retention of assemblies.

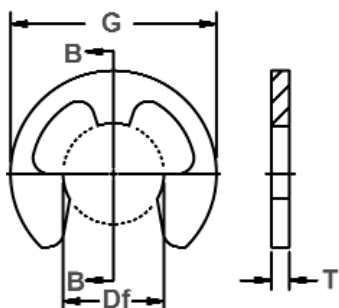

Free Diameter & Ring Measurements
With Section B-B

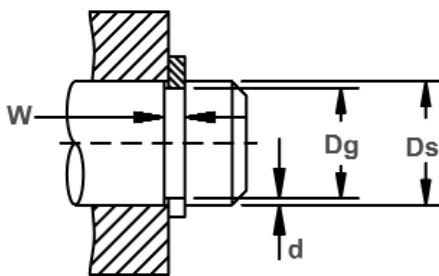

Shaft Diameter &
Groove Dimensions

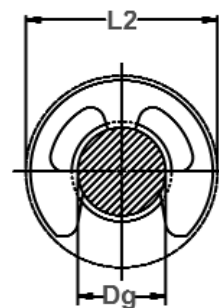

Clearance Diameter &
Installed In Groove

RING NO.	SHAFT DIAMETER		GROOVE SIZE					RING SIZE & WEIGHT					CLEARANCE DIA.		i THRUST LD (kN) Sqr. Corner Abutment		
	Ds mm	Ds DEC	DIAMETER		WIDTH	DEPTH	FREE DIAMETER		THICKNESS***	Wt. Per 1000 Pcs.	Free Out- Side Dia. Ref.	Re- leased In Groove	Ring (Safety factor of 3)	Groove (Safety factor of 2)			
			Dg	Tol.			F.I.M.**	Tol.							d	Df	Tol.
ME-1*	1	.039	0.72	-0.05	0.04	0.32	+0.05	0.14	0.64		0.25	±0.05	0.004	2.0	2.2	0.06	0.02
ME-2	2	.079	1.45		0.04	0.32		0.28	1.30		0.25		0.014	4.0	4.3	0.13	0.09
ME-3	3	.118	2.30		0.04	0.50	+0.10	0.35	2.10	+0.03	0.40		0.036	5.6	6.0	0.30	0.17
ME-4	4	.157	3.10	-0.08	0.05	0.70		0.45	2.90	-0.08	0.60		0.095	7.2	7.6	0.70	0.30
ME-5	5	.197	3.90		0.05	0.70		0.55	3.70		0.60		0.13	8.5	8.9	0.90	0.40
ME-6	6	.236	4.85		0.05	0.70		0.58	4.70		0.60		0.21	11.1	11.5	1.10	0.60
ME-7	7	.275	5.55		0.08	0.70		0.73	5.25		0.60		0.34	13.4	14.0	1.20	0.80
ME-8	8	.315	6.40		0.08	0.70		0.80	6.15		0.60		0.35	14.6	15.1	1.40	1.00
ME-9	9	.354	7.20	-0.10	0.08	1.00		0.90	6.80		0.90	±0.06	0.58	15.8	16.5	3.00	1.30
ME-10	10	.393	8.00		0.08	1.00	+0.15	1.00	7.60	+0.05	0.90		0.68	16.8	17.5	3.40	1.60
ME-11	11	.433	8.90		0.10	1.00		1.05	8.55	-0.10	0.90		0.68	17.4	18.0	3.70	1.90
ME-12	12	.472	9.60		0.10	1.20		1.20	9.20		1.10		1.00	18.6	19.3	4.90	2.30
ME-13	13	.512	10.30		0.10	1.20		1.35	9.95		1.10		1.13	20.3	21.0	5.40	2.90
ME-15	15	.591	11.80	-0.15	0.10	1.20		1.60	11.40		1.10		1.40	22.8	23.5	6.20	4.00
ME-16	16	.630	12.50		0.10	1.20		1.75	12.15		1.10		1.45	23.8	24.5	6.60	4.50
ME-18	18	.709	14.30		0.10	1.40		1.85	13.90	+0.10	1.30		2.3	27.2	27.9	8.70	5.40
ME-20	20	.787	16.00		0.10	1.40		2.00	15.60	-0.15	1.30		2.8	30.0	30.7	9.80	6.50
ME-22	22	.866	17.40	-0.20	0.10	1.40		2.30	17.00		1.30		3.4	33.0	33.7	10.80	8.10
ME-25	25	.984	20.00		0.10	1.40		2.50	19.50		1.30		4.2	37.1	37.9	12.20	10.10

* AVAILABLE IN BERYLLIUM COPPER ONLY.

** F.I.M. (FULL INDICATOR MOVEMENT)- MAXIMUM ALLOWABLE DEVIATION OF CONCENTRICITY BETWEEN GROOVE AND SHAFT.

i BASED ON GROOVES MADE OF COLD ROLLED STEEL. FOR AN EXPLANATION OF FORMULAS USED TO DERIVE THRUST LOAD AND OTHER PERFORMANCE DATA CONTACT THE ROTOR CLIP ENGINEERING DEPARTMENT.

*** FOR PLATED RINGS, ADD 0.05 TO THE LISTED MAXIMUM THICKNESS. MAXIMUM THICKNESS WILL BE A MINIMUM OF 0.005 LESS THAN THE LISTED GROOVE WIDTH (W) MINIMUM.

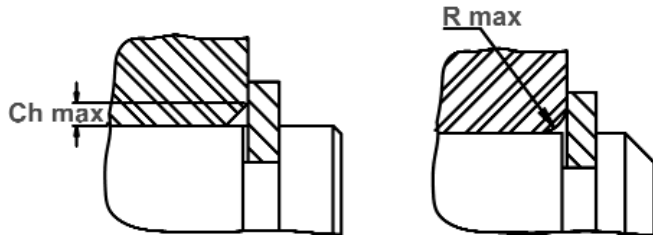

Maximum Corner Radius & Chamfer

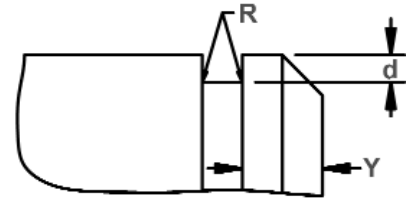

Exploded Groove Profile & Edge Margin (Y)
 Maximum bottom radii (R), 0.05 for ring sizes
 -1 thru -2; 0.15 for ring sizes -3 thru -7;
 0.25 for ring sizes -8 thru -13
 0.40 for ring sizes -15 thru -25

RING NO.	ALLOWABLE CORNER RADII & CHAMFERS		MAX. LOAD w/ R max or Ch max (kN)	EDGE MARGIN		R.P.M. LIMITS Standard Material
	R max	Ch max		P'r	Y	
ME-1*	0.4	0.25	0.06	0.3	40000	
ME-2	0.8	0.50	0.13	0.6	40000	
ME-3	1.1	0.70	0.30	0.7	34000	
ME-4	1.6	1.20	0.70	0.9	31000	
ME-5	1.6	1.20	0.90	1.1	27000	
ME-6	1.6	1.20	1.10	1.2	25000	
ME-7	1.6	1.20	1.20	1.5	23000	
ME-8	1.7	1.30	1.40	1.6	21500	
ME-9	1.7	1.30	3.00	1.8	19500	
ME-10	1.7	1.30	3.40	2.0	18000	
ME-11	1.7	1.30	3.70	2.1	16500	
ME-12	1.9	1.40	4.90	2.4	15000	
ME-13	2.0	1.50	5.40	2.7	13000	
ME-15	2.0	1.50	6.20	3.2	11500	
ME-16	2.0	1.50	6.60	3.5	10000	
ME-18	2.1	1.60	8.70	3.7	9000	
ME-20	2.2	1.70	9.80	4.0	8000	
ME-22	2.2	1.70	10.80	4.6	7000	
ME-25	2.4	1.90	12.20	5.0	5000	

LARGER SIZES MAY BE AVAILABLE UPON REQUEST.

HARDNESS RANGES: STAINLESS STEEL RINGS (PH 15-7MO)

RING TYPE	SIZE RANGE	SCALE	ROCKWELL HARDNESS
ME	2-3	15N	82.5-86*
	4-8	30N	63-69.5
	9-25	C	44-51

HARDNESS RANGES: BERYLLIUM COPPER RINGS

RING TYPE	SIZE RANGE	SCALE	ROCKWELL HARDNESS
ME	1-3	15N	79-82*
	4-9	30N	56.5-68
	10-25	C	37-43

HARDNESS RANGES: CARBON STEEL RINGS (SAE 1060-1090)

RING TYPE	SIZE RANGE	SCALE	ROCKWELL HARDNESS
ME	2-3	15N	85-87*
	4-8	30N	67.5-71
	9-25	C	48-52

*HARDNESS CAN NOT BE CHECKED WITH ANY DEGREE OF ACCURACY DIRECTLY ON THESE RINGS.

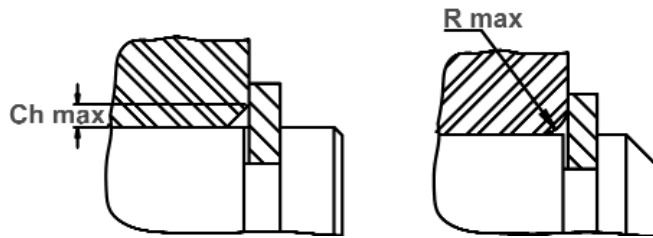

Maximum Corner Radius & Chamfer

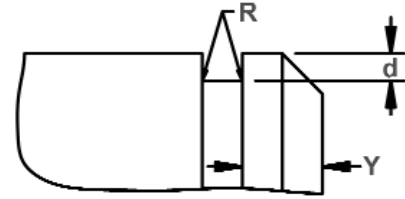

Exploded Groove Profile & Edge Margin (Y)
 Maximum bottom radii (R), 0.10 for ring sizes
 -3 thru -4; 0.20 for ring sizes -5 thru -16;
 0.30 for ring sizes -17 thru -30
 0.40 for ring sizes -32 thru -55

RING NO.	MAXIMUM SECTION	ALLOWABLE CORNER RADII & CHAMFERS		MAX. LOAD w/ R max or Ch max (kN)	EDGE MARGIN	R.P.M.
		Smax/Ref.	R max			
MC-3	0.90	0.4	0.30	0.4	1.0	80000
MC-4	1.00	0.4	0.30	0.4	1.2	80000
MC-5	1.20	0.6	0.45	0.7	1.5	80000
MC-6	1.30	0.6	0.45	0.7	1.5	80000
MC-7	1.40	0.6	0.45	0.7	1.5	69000
MC-8	1.60	0.6	0.45	0.7	1.5	67000
MC-9	1.70	0.6	0.45	0.7	1.5	58000
MC-10	1.70	0.6	0.45	0.7	1.5	50000
MC-11	1.80	0.6	0.45	0.7	1.5	40000
MC-12	1.90	0.6	0.45	0.7	1.7	35000
MC-13	2.00	1.0	0.8	2.0	1.8	30000
MC-14	2.00	1.0	0.8	2.0	2.0	27000
MC-15	2.10	1.0	0.8	2.0	2.1	25000
MC-16	2.20	1.0	0.8	2.0	2.3	24000
MC-17	2.25	1.0	0.8	2.0	2.4	23000
MC-18	2.30	1.2	0.9	2.8	2.6	21000
MC-19	2.40	1.2	0.9	2.8	2.7	20500
MC-20	2.55	1.2	0.9	3.0	2.9	20000
MC-22	2.80	1.2	0.9	3.0	3.2	16500
MC-23	2.90	1.2	0.9	3.2	3.3	15200
MC-24	3.00	1.2	0.9	3.2	3.5	15100
MC-25	3.15	1.2	0.9	3.2	3.6	15000
MC-26	3.25	1.2	0.9	3.2	3.8	14500
MC-28	3.50	1.5	1.15	6.3	4.2	13200
MC-30	3.70	1.5	1.15	6.4	4.5	13000
MC-32	4.00	1.5	1.15	6.6	4.8	12900
MC-35	4.30	1.5	1.15	6.8	5.3	11000
MC-36	4.40	1.5	1.15	6.8	5.4	10200
MC-38	4.60	1.5	1.15	7.1	5.7	9600
MC-40	4.90	1.5	1.15	7.2	6.0	9200
MC-42	5.10	1.5	1.15	7.4	6.3	8600
MC-45	5.50	1.5	1.15	7.6	6.8	8300
MC-48	5.90	1.5	1.15	7.9	7.2	7500
MC-50	6.20	2.0	1.5	12.0	7.5	6800
MC-52	6.30	2.0	1.5	12.0	7.5	6600
MC-55	6.50	2.0	1.5	12.0	7.5	6500

LARGER SIZES MAY BE AVAILABLE UPON REQUEST.

HARDNESS RANGES: STAINLESS STEEL RINGS (PH 15-7M0)

RING TYPE	SIZE RANGE	SCALE	ROCKWELL HARDNESS
MC	3-4	15N	82.5-86
	5-19	30N	63-69.5
	20-55	C	44-51

HARDNESS RANGES: CARBON STEEL RINGS (SAE 1060-1090)

RING TYPE	SIZE RANGE	SCALE	ROCKWELL HARDNESS
MC	3-4	15N	84-86
	5-19	30N	66-69.5
	20-55	C	47-51



MRE Shaft Rings

Radially Assembled, External Reinforced 'E', ANSI Metric

The MRE retaining ring is a reinforced version of the ME ring, which will accommodate higher thrust loadings and RPM. MRE rings function in the same size grooves as regular E rings, so that you can change from one to the other without re-engineering the application.

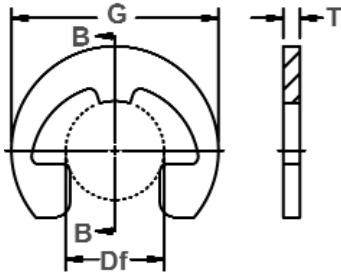

Free Diameter & Ring Measurements
With Section B-B

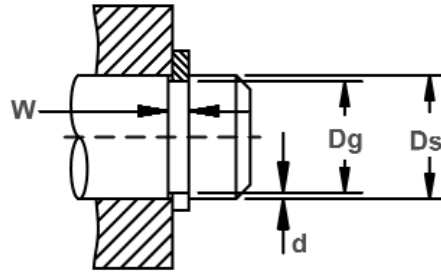

Shaft Diameter &
Groove Dimensions

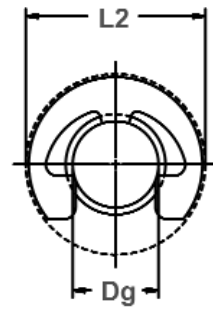

Clearance Diameter
Installed in Groove

RING NO.	SHAFT DIAMETER		GROOVE SIZE				RING SIZE & WEIGHT				CLEARANCE		I THRUST LD (kN)					
			DIAMETER		WIDTH	DEPTH	FREE DIAMETER		THICKNESS***	Wt. Per 1000 Pcs.	Free Out-Side Dia. Ref.	Re-leased In Groove	Ring (Safety factor of 3)	Groove (Safety factor of 2)				
	Ds mm	Ds DEC	Dg	Tol.	F.I.M.*	W	Tol.	d	Df	Tol.	T	Tol.	kg	G	L2	Pr	Pg	
MRE-4	4	0.157	3.00	-0.05	0.05	0.7	+0.15	0.50	2.90	+0.05-0.08	0.6	±0.06	0.14	8.50	8.9	0.6	0.18	
MRE-5	5	0.197	3.85	-0.10	0.05	0.7		0.57	3.65	+0.08	0.6		0.6	0.18	9.50	9.9	0.8	0.27
MRE-6	6	0.236	4.85		0.05	0.7		0.57	4.65		0.6			0.24	11.35	11.8	1.0	0.34
MRE-7	7	0.276	5.40		0.08	0.7		0.80	5.20		0.6			0.32	13.10	13.7	1.1	0.54
MRE-8	8	0.315	6.40	-0.15	0.08	0.7		0.80	6.15	-0.10	0.6		0.9	0.36	14.95	15.6	1.3	0.63
MRE-9	9	0.354	7.10		0.10	1.0		0.95	6.75		0.9			0.60	15.70	16.4	2.2	0.80
MRE-10	10	0.394	7.80		0.10	1.0		1.10	7.45		0.9			0.68	16.75	17.5	2.4	1.10
MRE-11	11	0.433	8.80		0.10	1.0		1.10	8.45		0.9			0.86	18.95	19.7	2.7	1.20
MRE-12	12	0.472	9.50		0.10	1.2		1.25	9.10		1.1			1.20	19.60	20.4	3.5	1.50
MRE-13	13	0.512	10.2	0.10	1.2	1.40		9.80	1.1	1.45	20.55		21.3	3.9	1.70			
MRE-14	14	0.551	11.2		0.10	1.2		1.40	10.90	1.1	1.60		22.10	22.8	4.2	1.90		
MRE-15	15	0.591	11.8		0.10	1.2		1.60	11.50	1.1	1.75		23.20	23.9	4.5	2.30		

*F.I.M. (FULL INDICATOR MOVEMENT)-MAXIMUM ALLOWABLE DEVIATION OF CONCENTRICITY BETWEEN GROOVE AND SHAFT.

† BASED ON HOUSINGS/SHAFTS MADE OF COLD ROLLED STEEL. FOR AN EXPLANATION OF FORMULAS USED TO DERIVE THRUST LOAD AND OTHER PERFORMANCE DATA, CONTACT THE ROTOR CLIP ENGINEERING DEPT.

*** FOR PLATED RINGS, ADD 0.05 TO THE LISTED MAXIMUM THICKNESS. MAXIMUM RING THICKNESS WILL BE A MINIMUM OF 0.005 LESS THAN THE LISTED GROOVE WIDTH (W) MINIMUM.

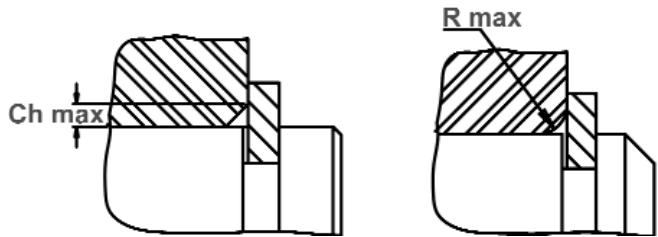

Maximum Corner Radius & Chamfer

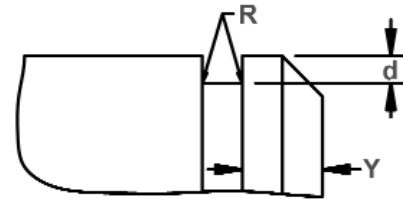

Exploded Groove Profile & Edge Margin (Y)
Maximum bottom radii (R), 0.1 for ring sizes
-4; 0.15 for ring sizes -5 thru -9;
0.25 for ring sizes -10 thru -15

RING NO.	CORNER RADII & CHAMFERS		LOAD w/ R max or Ch max (kN)	MARGIN	LIMITS Standard Material
	R max	Ch max			
MRE-4	1.6	1.3	0.6	1.0	50000
MRE-5	1.6	1.3	0.8	1.1	43000
MRE-6	1.6	1.3	1.0	1.1	38000
MRE-7	1.6	1.3	1.1	1.6	33000
MRE-8	1.6	1.3	1.3	1.6	28000
MRE-9	1.8	1.4	2.2	1.9	27000
MRE-10	1.8	1.4	2.4	2.2	25000
MRE-11	1.8	1.4	2.7	2.2	21500
MRE-12	2.0	1.5	3.5	2.5	19500
MRE-13	2.0	1.5	3.9	2.8	17500
MRE-14	2.0	1.5	4.2	2.8	15500
MRE-15	2.0	1.5	4.5	3.2	14000

NOTE: CONTACT ROTOR CLIP FOR AVAILABILITY OF SIZES LISTED.
LARGER SIZES MAY BE AVAILABLE UPON REQUEST.

HARDNESS RANGES: STAINLESS STEEL RINGS (PH 15-7MO)

RING TYPE	SIZE RANGE	SCALE	ROCKWELL HARDNESS
MRE	4-8	30N	63-69.5
	9-15	C	44-51

HARDNESS RANGES: CARBON STEEL RINGS (SAE 1060-1090)

RING TYPE	SIZE RANGE	SCALE	ROCKWELL HARDNESS
MRE	4-8	30N	67.5-71
	9-15	C	48-52

Radially Assembled, External 'E', JIS

Perhaps the most popular and widely used radial retaining ring is the "E" (so named because it is shaped like the letter "E").

Three prongs make contact with the bottom of the groove and provide a shoulder for effective retention of assemblies.

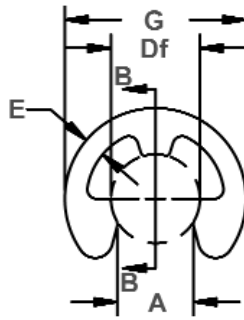

Free Diameter & Ring Measurements
With Section B-B

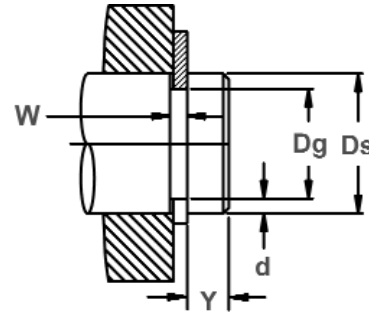
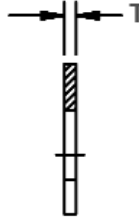

Shaft Diameter & Groove Dimensions

RING NO.	SHAFT Diameter Ds (mm)		GROOVE SIZE				RING SIZE									
	From	To	DIAMETER		WIDTH		EDGE MARGIN Y Min.	FREE DIAMETER		THICKNESS ***		GAP		BEAM WIDTH E	FREE OUTSIDE DIA. G	Tol.
			Dg	Tol.	W	Tol.		Df	Tol.	T	Tol.	A	Tol.			
JE-0,8	1	1,4	0,8	+0,05	0,3	+0,05	0,4	0,8	-0,08	0,2	±0,02	0,7	-0,25	0,3	2	±0,1
JE-1,2	1,4	2,0	1,2	+0,06	0,4		0,6	1,2	-0,09	0,3	±0,025	1		-0,30	0,4	
JE-1,5	2,0	2,5	1,5		+0,075	0,5	+0,10	0,8		1,5	-0,12	0,4	±0,03		1,3	-0,35
JE-2	2,5	3,2	2,0	0,5		1,0		2	0,4	2,5		0,4		2,1	0,8	
JE-2,5	3,2	4,0	2,5	+0,09	0,5	+0,14	1,0	2,5	-0,15	0,4	±0,04	2,1	-0,40	0,8	6	±0,3
JE-3	4,0	5,0	3,0		0,7		1,0	3		0,6		3		0,6	2,6	
JE-4	5,0	7,0	4,0	+0,11	0,7	+0,14	1,2	4	-0,18	0,6	±0,05	3,5	-0,45	1,1	9	±0,2
JE-5	6,0	8,0	5,0		0,7		1,2	5		0,6		5		0,8	4,3	
JE-6	7,0	9,0	6,0	+0,13	0,9	+0,14	1,2	6	-0,21	0,8	±0,06	5,2	-0,50	1,4	12	±0,3
JE-7	8,0	11,0	7,0		0,9		1,5	7		0,8		7		0,8	6,1	
JE-8	9,0	12,0	8,0	+0,13	0,9	+0,14	1,8	8	-0,21	0,8	±0,07	6,9	-0,50	1,8	16	±0,3
JE-9	10,0	14,0	9,0		0,9		2,0	9		0,8		9		0,8	7,8	
JE-10	11,0	15,0	10,0	+0,13	1,15	+0,14	2,0	10	-0,21	1,0	±0,05	8,7	-0,50	2,2	20	±0,3
JE-12	13,0	18,0	12,0		1,15		2,5	12		1,0		12		1,0	10,4	
JE-15	16,0	24,0	15,0	+0,13	1,65	+0,14	3,0	15	-0,21	1,5	±0,06	13,0	-0,50	2,8	29	±0,3
JE-19	20,0	31,0	19,0		1,65		3,5	19		1,5		19		1,5	16,5	
JE-24	25,0	38,0	24,0	+0,13	2,2	+0,14	4,0	24	-0,21	2,0	±0,07	20,8	-0,50	5,0	44	±0,3

ALL DIMENSIONS IN MILLIMETERS.

***FOR PLATED RINGS, ADD 0.05 TO THE LISTED MAXIMUM THICKNESS. MAXIMUM RING THICKNESS WILL BE A MINIMUM OF 0.005 LESS THAN THE LISTED GROOVE WIDTH (W) MINIMUM.

HARDNESS RANGES: STAINLESS STEEL RINGS (PH 15-7MO)

RING TYPE	SIZE RANGE	SCALE	ROCKWELL HARDNESS
JE	0,8-2,5	15N	82.5-86*
	3-9	30N	63-69.5
	10-24	C	44-51

HARDNESS RANGES: BERYLLIUM COPPER RINGS

RING TYPE	SIZE RANGE	SCALE	ROCKWELL HARDNESS
JE	0,8-2,5	15N	79-82*
	3-9	30N	56.5-62
	10-24	C	37-43

HARDNESS RANGES: CARBON STEEL RINGS (SAE 1060-1090)

RING TYPE	SIZE RANGE	SCALE	ROCKWELL HARDNESS
JE	0,8-2,5	15N	82.5-87
	3-9	30N	63-71
	10-24	C	44-53

*HARDNESS CAN NOT BE CHECKED WITH ANY DEGREE OF ACCURACY DIRECTLY ON THESE RINGS.

Installation tools can be found at rotorclip.com/pliers_tools_applicators_kits

Once installed in the groove of a shaft, the portion of the ring protruding from the groove holds an assembly in place.

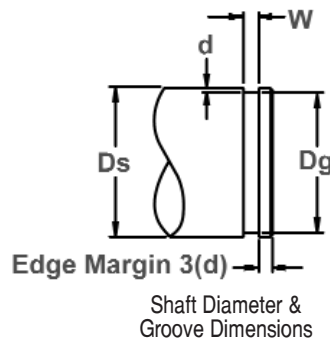
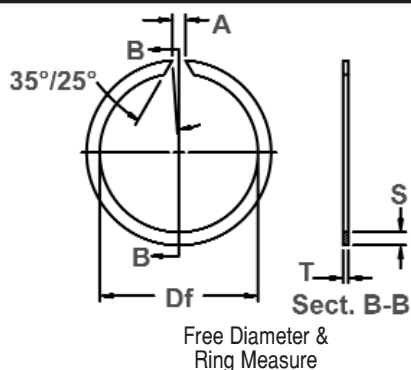

Material: SAE 1060-1075

RING SIZE	SHAFT DIAMETER			GROOVE SIZE			RING DIMENSIONS			FREE GAP A		ALLOWABLE STATIC THRUST LOAD (Lbs.)			
				DIAMETER		WIDTH	DEPTH	FREE DIAMETER	THICKNESS				SECTION		
	Ds DEC	Ds FRACT.	Ds mm	Dg	TOL.	W	d	Df	TOL.	T +/- .002	S +/- .005		TOL.	Min	Max
USC-156	1.562	1-9/16	39.67	1.490	+/- .004	.068 +.004 -.000	.036	1.467	+.000 -.046	.062	.125	+/- .005	.156	.375	3060
USC-162	1.625	1-5/8	41.28	1.551			.037	1.527		.062	.125		.156	.375	3190
USC-168	1.688	1-11/16	42.90	1.611			.038	1.581		.062	.125		.156	.375	3370
USC-175	1.750	1-3/4	44.40	1.670			.04	1.640		.062	.125		.156	.375	3510
USC-177	1.772	-	45.00	1.687			.042	1.657		.062	.141		.156	.375	3550
USC-181	1.812	1-13/16	46.00	1.728			.042	1.698		.062	.141		.156	.375	3640
USC-187	1.875	1-7/8	47.60	1.789			.043	1.759		.062	.156		.156	.375	3760
USC-196	1.969	1-31/32	50.00	1.879			.045	1.849		.062	.156		.156	.375	3940
USC-200	2.000	2	50.80	1.910			.045	1.880		.062	.156		.156	.375	4010
USC-206	2.062	2-1/16	52.40	1.966			.048	1.936		.078	.156		.156	.375	5350
USC-212	2.125	2-1/8	54.00	2.027			.049	1.997		.078	.156		.156	.375	5470
USC-215	2.156	2-5/32	54.80	2.056	.050	2.026	.078	.156	.156	.375	5680				
USC-225	2.250	2-1/4	57.10	2.146	.052	2.116	.078	.156	.156	.375	5790				
USC-231	2.312	2-5/16	58.70	2.204	.054	2.174	.078	.187	.156	.375	6300				
USC-237	2.375	2-3/8	60.30	2.265	.055	2.235	.078	.187	.156	.375	6400				
USC-243	2.438	2-7/16	61.90	2.325	.056	2.295	.078	.187	.156	.375	6500				
USC-250	2.500	2-1/2	63.50	2.386	.057	2.356	.078	.187	.156	.375	6600				
USC-255	2.559	-	65.00	2.443	.058	2.413	.078	.187	.156	.375	6700				
USC-262	2.625	2-5/8	66.70	2.505	.060	2.475	.078	.187	.156	.375	6800				
USC-268	2.688	2-11/16	68.30	2.565	.061	2.535	.078	.187	.156	.375	6900				
USC-275	2.750	2-3/4	69.80	2.624	.063	2.594	.093	.187	.187	.437	8460				
USC-287	2.875	2-7/8	73.00	2.743	.066	2.713	.093	.187	.187	.437	8840				
USC-293	2.938	2-15/16	74.60	2.801	.068	2.771	.093	.187	.187	.437	9030				
USC-300	3.000	3	76.20	2.860	.070	2.830	.093	.218	.187	.437	9230				
USC-306	3.062	3-1/16	77.80	2.920	.071	2.890	.093	.218	.187	.437	9420				
USC-312	3.125	3-1/8	79.40	2.981	.072	2.951	.093	.218	.187	.437	9630				
USC-315	3.156	3-5/32	80.20	3.010	.073	2.980	.093	.218	.187	.437	9800				
USC-325	3.250	3-1/4	82.50	3.100	.075	3.070	.093	.250	.187	.437	10000				
USC-334	3.346	3-11/32	85.00	3.190	.077	3.160	.093	.250	.187	.437	10290				
USC-343	3.438	3-7/16	87.3	3.281	.078	3.251	.093	.250	.187	.437	10570				

Hardness: All ring sizes - HRC 42-53

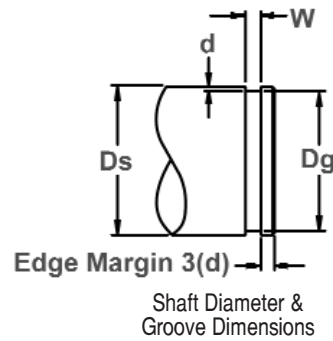
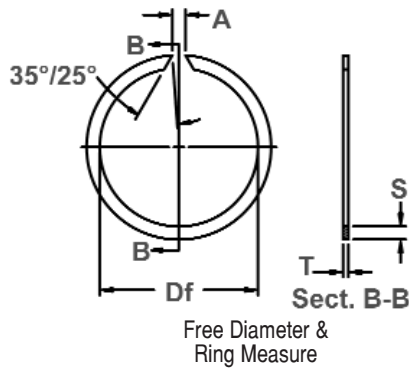

Material: SAE 1060-1075

RING SIZE	SHAFT DIAMETER			GROOVE SIZE					RING DIMENSIONS					ALLOWABLE STATIC THRUST LOAD (Lbs.)						
				DIAMETER		WIDTH	DEPTH	FREE DIAMETER		THICKNESS	SECTION		FREE GAP A							
	Ds DEC	Ds FRACT.	Ds mm	Dg	TOL.	W	d	Df	TOL.	T +/- .002	S +/- .005	TOL.	Min		Max					
USC-350	3.500	3-1/2	88.9	3.340	+/- .006	.120	.080	3.305	+ .000	.109	.250	+/- .005	.250	.562	11970					
USC-354	3.543	-	90.0	3.381			.081	3.346		.109	.250									
USC-362	3.625	3-5/8	92.1	3.458			.083	3.423		.109	.250									
USC-368	3.688	3-11/16	93.7	3.517			- .078	.120	.085	3.482	+ .000		.109	.250	.250	.562	12300			
USC-375	3.750	3-3/4	95.2	3.576					.087	3.541			.109	.250						
USC-387	3.875	3-7/8	98.4	3.697					.089	3.657			.109	.281						
USC-393	3.938	3-15/16	100.0	3.758					.090	3.713			.109	.281						
USC-400	4.000	4	101.6	3.816					.092	3.771			.109	.281						
USC-425	4.250	4-1/4	108.0	4.066					- .093	.139			.092	4.016	+ .000	.109	.281	.250	.656	13650
USC-437	4.375	4-3/8	111.1	4.191									.092	4.141		.109	.281			
USC-450	4.500	4 1/2	114.3	4.310									.095	4.255		.109	.312			
USC-475	4.750	4-3/4	120.6	4.550									.100	4.495		.109	.312			
USC-500	5.000	5	127.0	4.790									.105	4.730		.109	.312			
USC-525	5.250	5-1/4	133.3	5.030			- .000	.174			.110		4.970	+ .000		.125	.375	.250	.750	15000
USC-550	5.500	5-1/2	139.7	5.266							.117		5.206			.125	.375			
USC-575	5.750	5-3/4	146.0	5.506							.122		5.446			.125	.375			
USC-590	5.900	-	149.9	5.656							.122		5.600			.125	.375			
USC-600	6.000	6	152.4	5.746	.127	5.687					.125	.375								
USC-625	6.250	6-1/4	158.7	5.986	- .000	.209			.132	5.916	+ .000	.156	.437		.250	.750	20590			
USC-650	6.500	6-1/2	165.1	6.226					.137	6.151		.156	.437							
USC-675	6.750	6-3/4	171.4	6.466					.142	6.386		.156	.437							
USC-700	7.000	7	177.8	6.706					.147	6.621		.156	.437							
USC-725	7.250	7-1/4	184.2	6.930					+ .008	.209		.160	6.840		- .156	.187	.500	.250	.875	30310
USC-750	7.500	7-1/2	190.5	7.180			.160	7.090				.187	.500							
USC-800	8.000	8	203.2	7.660			.170	7.560				.187	.500							
USC-850	8.500	8-1/2	215.9	8.160			.170	8.050				.187	.500							
USC-900	9.000	9	228.6	8.660			.170	8.545				.187	.500							
USC-925	9.250	9-1/4	234.9	8.910			- .000	.170				.170	8.800	.187		.500	.250	.875	43100	
USC-950	9.500	9-1/2	241.3	9.160	.170	9.040					.187	.500								
USC-975	9.750	9-3/4	247.6	9.410	+ .000	.170					.170	8.925	.187	.500		.250	.875	44500		
USC-1000	10.000	10	254.0	9.660							.170	9.535	.187	.500		.250	.875	45500		

Hardness: All ring sizes - HRC 42-53

Snap Ring, External, Metric

For SAE Standard Metric Bearings.

Once installed in the groove of a shaft, the portion of the ring protruding from the groove holds an assembly in place.

SB Constant Section

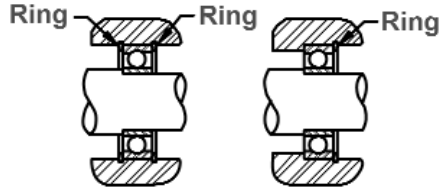

Drawing depicts using rings to retain bearings in a typical shaft application.

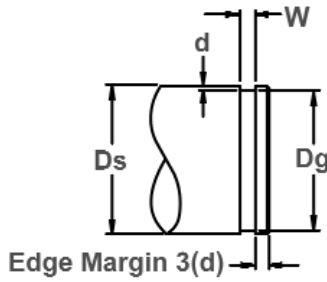

Shaft Diameter & Groove Dimensions

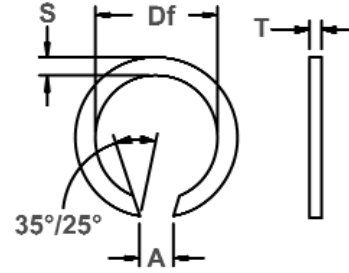

Free Diameter & Ring Measurements

RING NUMBER	SHAFT DIAMETER		BEARING NUMBER			GROOVE DIAMETER			RING DIMENSIONS							
						DIAMETER		WIDTH	DEPTH	FREE DIAMETER		THICKNESS	SECTION		FREE GAP	
	Ds DEC	Ds mm				Dg	TOL.	W	d	Df	Tol.	T ±.002	S	A Min.	A Max.	
SB-12	.4724	12.00	201	301	--	.436	±.002	.046 +.003 -.000	.018	.421	+ .000 -.020	.042	.062 ±.003	.062	.187	
SB-15	.5906	15.00	202	302	--	.550		.053	.020	.538	+ .000	.047	.078	.078	.218	
SB-17	.6693	17.00	203	303	403	.629		+ .004 -.000	.020	.616	- .025	.047	±.003	.078	.218	
SB-20	.7874	20.00	204	304	404	.731	±.002	.068	.028	.710	+ .000	.062	.093 ±.003	.078	.218	
SB-25	.9843	25.00	205	305	405	.924		+ .004 -.000	.030	.910		- .031	.062	.109 ±.003	.156	.312
SB-30	1.1811	30.00	206	306	406	1.111		.085 +.004 -.000	.035	1.093		+ .000	.075	.125 ±.005	.156	.312
SB-35	1.3780	35.00	207	307	407	1.288	.108	.045	1.265	- .031	.093		.156	.250	.406	
SB-40	1.5748	40.00	208	308	408	1.465	+ .005	.055	1.452	+ .000	.093		±.005	.250	.406	
SB-45	1.7717	45.00	209	309	409	1.648	- .000	.062	1.625		- .046	.093	.188	.250	.468	
SB-50	1.9685	50.00	210	310	410	1.844		.062	1.820		+ .000	.093	±.005	.250	.468	
SB-55	2.1654	55.00	211	311	411	2.015	.120	.075	1.995	- .046		.109	.218	.250	.468	
SB-60	2.3622	60.00	212	312	412	2.212	+ .005 -.000	.075	2.187	+ .000		.109	±.005	.250	.468	
SB-65	2.5591	65.00	213	313	413	2.389		.085	2.359		+ .000	.125	.250 ±.005	.250	.468	
SB-70	2.7559	70.00	214	314	414	2.586		.085	2.556			- .062		.125	.250	.500
SB-75	2.9528	75.00	215	315	415	2.783	±.006	.139	.085	2.750		+ .000		.125	±.005	.250
SB-80	3.1496	80.00	216	316	416	2.979		+ .006	.085	2.946	- .062	.125	.250	.500		
SB-85	3.3465	85.00	217	317	417	3.176		- .000	.085	3.139	+ .000	.125	.312 ±.005	.250	.500	
SB-90	3.5433	90.00	218	318	418	3.343		.100	3.308	- .078		.125		.312	.625	
SB-95	3.7402	95.00	219	319	419	3.540		.100	3.500	+ .000		.125		±.005	.312	.625
SB-100	3.9370	100.00	220	320	420	3.737	±.006	.174	.100		3.697	- .078	.156	.312	.625	
SB-105	4.1339	105.00	221	321	421	3.934		+ .008	.100		3.888	+ .000	.156	.312	.625	
SB-110	4.3307	110.00	222	322	422	4.131		- .000	.100	4.080	- .093	.156	.312	.687		

Hardness: All Ring Sizes - HRC 42-52

For alternate cutoff styles, contact Rotor Clip Technical Sales at 1-800-557-6867 (E-mail: tech@rotorclip.com)



For the most up-to-date specifications, online ordering, quotations & sample orders, visit www.rotorclip.com

CFS Constant Section

Snap Ring, External, Metric

Flat Wire.

Once installed in the groove of a shaft, the portion of the ring protruding from the groove holds an assembly in place.

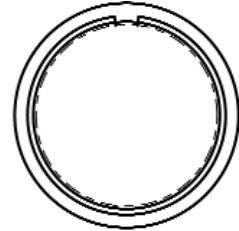
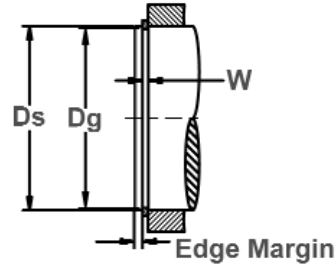
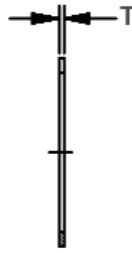
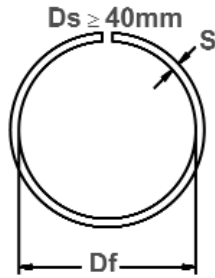
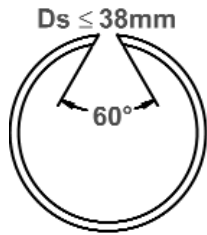

$$\text{Edge Margin} = \frac{D_s - D_g}{2}$$

Free Diameter & Ring Dimensions

Shaft Diameter & Groove Dimensions

RING SIZE	SHAFT DIAMETER		GROOVE DIMENSIONS		RING DIMENSIONS & WEIGHT				SUPPLEMENTARY DATA			
	Ds DEC	Ds mm	DIAMETER		W min	Df max	T -0,1	S -0,1	WEIGHT kg/1000	Pg (kN)	Pr (kN)	R.P.M. X1000 (1/min)
			Dg	TOL.								
CFS-4	0.1575	4	3,8	-0,09	0,6	3,7	0,5	0,80	0,02	0,20	1,25	275,0
CFS-5	0.1969	5	4,8		0,6	4,7	0,5	1,00	0,05	0,26	1,30	192,0
CFS-6	0.2362	6	5,7		0,8	5,6	0,7	1,10	0,09	0,46	3,50	141,0
CFS-7	0.2756	7	6,7		0,8	6,5	0,7	1,20	0,12	0,54	3,50	134,0
CFS-8	0.3150	8	7,6		1,1	7,4	1,0	1,30	0,20	0,82	6,50	108,0
CFS-9	0.3543	9	8,6	1,1	8,4	1,0	1,30	0,24	0,92	6,50	80,0	
CFS-10	0.3937	10	9,6	1,1	9,4	1,0	1,30	0,25	1,03	6,50	68,0	
CFS-11	0.4331	11	10,5	1,1	10,2	1,0	1,30	0,29	1,40	9,80	64,0	
CFS-12	0.4724	12	11,5	1,1	11,2	1,0	1,30	0,30	1,53	9,30	53,0	
CFS-13	0.5118	13	12,5	1,1	12,2	1,0	1,30	0,34	1,70	8,90	43,0	
CFS-14	0.5512	14	13,5	1,3	13,1	1,2	1,50	0,50	1,80	17,00	45,0	
CFS-15	0.5906	15	14,4	1,3	14,0	1,2	1,75	0,66	2,30	18,70	44,0	
CFS-16	0.6299	16	15,4	1,3	15,0	1,2	1,75	0,69	2,47	17,70	38,0	
CFS-17	0.6693	17	16,4	1,3	16,0	1,2	1,75	0,72	2,63	17,00	34,0	
CFS-18	0.7087	18	17,4	1,3	17,0	1,2	1,75	0,75	2,78	16,20	30,0	
CFS-19	0.7480	19	18,4	1,3	17,9	1,2	1,75	0,80	2,94	15,60	29,0	
CFS-20	0.7874	20	19,2	1,3	18,7	1,2	1,75	0,84	4,10	15,00	26,0	
CFS-21	0.8268	21	20,2	1,3	19,7	1,2	1,75	0,87	4,30	14,60	23,0	
CFS-22	0.8661	22	21,2	1,3	20,7	1,2	1,75	0,91	4,50	14,00	21,0	
CFS-24	0.9449	24	23,0	1,3	22,5	1,2	1,75	0,99	6,15	13,30	18,0	
CFS-25	0.9843	25	24,0	1,3	23,5	1,2	1,75	1,00	6,40	12,80	16,0	
CFS-26	1.0236	26	25,0	1,3	24,5	1,2	1,75	1,10	6,65	12,50	15,0	
CFS-27	1.0630	27	26,0	1,6	25,5	1,5	2,30	2,00	6,95	30,00	16,0	
CFS-28	1.1024	28	27,0	1,6	26,5	1,5	2,30	2,11	7,20	29,30	15,0	
CFS-29	1.1417	29	28,0	1,6	27,5	1,5	2,30	2,20	7,45	28,20	14,0	
CFS-30	1.1811	30	29,0	1,6	28,5	1,5	2,30	2,33	7,70	27,50	13,0	
CFS-32	1.2598	32	30,8	1,6	30,2	1,5	2,30	2,41	9,90	26,50	13,0	
CFS-35	1.3780	35	33,8	1,6	33,2	1,5	2,30	2,51	10,80	24,40	11,0	
CFS-37	1.4567	37	35,8	1,6	35,2	1,5	2,30	2,72	11,30	23,50	9,0	
CFS-38	1.4961	38	36,8	1,6	36,2	1,5	2,30	2,83	11,60	22,70	9,0	
CFS-40	1.5748	40	38,5	1,6	37,8	1,5	2,30	2,91	15,50	22,00	8,0	
CFS-42	1.6535	42	40,5	1,6	39,8	1,5	2,30	3,10	16,20	21,40	7,0	
CFS-43	1.6929	43	41,5	1,6	40,8	1,5	2,30	3,25	16,50	21,10	7,0	

Hardness: Sizes 4-20, 47-52 HRC; Sizes 21 & Over, 45-50 HRC

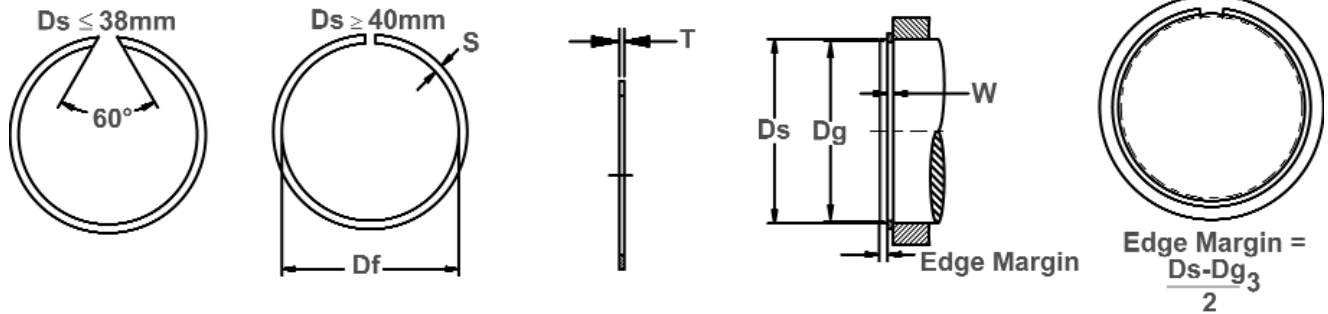

Free Diameter & Ring Dimensions

Shaft Diameter & Groove Dimensions

RING SIZE	SHAFT DIAMETER		GROOVE DIMENSIONS				RING DIMENSIONS & WEIGHT				SUPPLEMENTARY DATA		
	Ds DEC	Ds mm	DIAMETER		WIDTH W min	FREE DIAMETER Df max	THICKNESS T -0,1	SECTION S -0,1	WEIGHT kg/1000	Pg (kN)	Pr (kN)	R.P.M. X1000 (1/min)	
			Dg	TOL.									
CFS-45	1.7717	45	43,5	-0,16	1,6	42,8	1,5	2,30	3,39	17,30	20,60	6,0	
CFS-47	1.8504	47	45,5	-0,16	1,6	44,8	1,5	2,30	3,48	18,20	19,20	6,0	
CFS-48	1.8898	48	46,5	-0,16	1,6	45,8	1,5	2,30	3,60	18,70	18,60	5,0	
CFS-50	1.9685	50	48,5	-0,16	1,6	47,8	1,5	2,30	3,73	19,50	18,10	5,0	
CFS-52	2.0472	52	50,5	-0,19	1,6	49,8	1,5	2,30	3,92	20,20	17,70	4,0	
CFS-55	2.1654	55	53,5	-0,19	1,6	52,6	1,5	2,30	4,11	21,00	16,50	4,0	
CFS-58	2.2835	58	56,5	-0,19	1,6	55,6	1,5	2,30	4,40	22,50	15,70	4,0	
CFS-60	2.3622	60	58,5	-0,19	1,6	57,6	1,5	2,30	4,55	23,20	15,40	4,0	
CFS-63	2.4803	63	61,5	-0,19	1,6	60,6	1,5	2,30	4,58	24,40	14,70	3,0	
CFS-65	2.5591	65	63,5	-0,19	1,6	62,6	1,5	2,30	4,64	25,20	14,20	3,0	
CFS-68	2.6772	68	66,2	-0,19	2,2	65,4	2,0	2,80	8,59	31,70	39,60	3,0	
CFS-70	2.7559	70	68,2	-0,19	2,2	67,4	2,0	2,80	8,71	32,50	38,40	3,0	
CFS-72	2.8346	72	70,2	-0,19	2,2	69,4	2,0	2,80	8,80	33,70	37,60	3,0	
CFS-73	2.8740	73	71,2	-0,19	2,2	70,4	2,0	2,80	8,90	34,00	37,00	3,0	
CFS-75	2.9528	75	73,2	-0,19	2,2	72,4	2,0	2,80	9,32	35,00	36,20	2,0	
CFS-80	3.1496	80	78,2	-0,22	2,2	77,4	2,0	2,80	9,67	37,40	34,20	2,0	
CFS-85	3.3465	85	83,0	-0,22	2,7	82,0	2,5	3,40	16,00	44,00	72,00	2,0	
CFS-90	3.5433	90	88,0	-0,22	2,7	87,0	2,5	3,40	16,00	46,50	66,30	2,0	
CFS-95	3.7402	95	93,0	-0,22	2,7	92,0	2,5	3,40	18,20	49,20	61,80	2,0	
CFS-100	3.9370	100	98,0	-0,22	2,7	97,0	2,5	3,40	18,90	51,90	57,30	2,0	
CFS-105	4.1339	105	102,7	-0,22	2,7	101,7	2,5	3,40	20,70	65,00	54,00	2,0	
CFS-110	4.3307	110	107,7	-0,22	2,7	106,6	2,5	3,40	20,90	69,00	50,40	1,0	
CFS-115	4.5276	115	112,7	-0,22	2,7	111,6	2,5	3,40	22,10	71,00	47,20	1,0	
CFS-120	4.7244	120	117,7	-0,22	2,7	116,5	2,5	3,40	24,10	75,00	44,80	1,0	
CFS-125	4.9213	125	122,7	-0,25	2,7	121,5	2,5	3,40	25,10	78,50	41,80	1,0	
CFS-130	5.1181	130	127,7	-0,25	2,7	126,4	2,5	3,40	26,60	84,00	39,60	1,0	
CFS-135	5.3150	135	132,4	-0,25	2,7	131,1	2,5	4,00	30,20	87,00	44,00	1,0	
CFS-140	5.5118	140	137,4	-0,25	2,7	136,0	2,5	4,00	31,10	91,50	41,60	1,0	
CFS-145	5.7087	145	142,4	-0,25	2,7	141,0	2,5	4,00	32,60	95,00	39,60	1,0	
CFS-150	5.9055	150	147,4	-0,25	2,7	145,9	2,5	4,00	32,80	98,00	37,50	1,0	
CFS-155	6.1024	155	154,4	-0,25	2,7	150,9	2,5	4,00	34,70	100,00	36,30	1,0	
CFS-160	6.2992	160	157,4	-0,25	2,7	155,8	2,5	4,00	36,60	103,00	35,60	1,0	
CFS-165	6.4961	165	162,4	-0,25	2,7	160,8	2,5	4,00	37,40	106,00	34,20	0,5	

Hardness: Sizes 4-20, 47-52 HRC; Sizes 21 & Over, 45-50 HRC

CFS Constant Section

Snap Ring, External, Metric

Flat Wire.

Once installed in the groove of a shaft, the portion of the ring protruding from the groove holds an assembly in place.

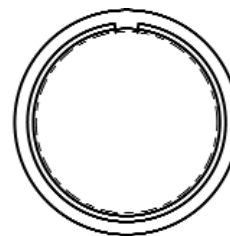
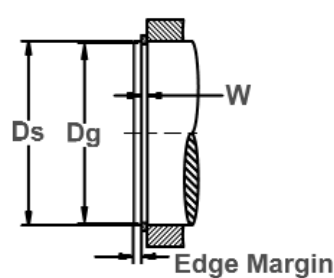
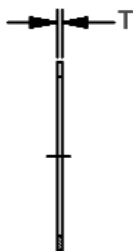
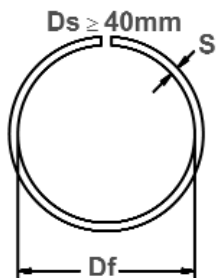

$$\text{Edge Margin} = \frac{D_s - D_g}{2}$$

Free Diameter & Ring Dimensions

Shaft Diameter & Groove Dimensions

RING SIZE	SHAFT DIAMETER		GROOVE DIMENSIONS		RING DIMENSIONS & WEIGHT				SUPPLEMENTARY DATA			
	Ds DEC	Ds mm	DIAMETER		W min	Df max	T -0,1	S -0,1	kg/1000	Pg (kN)	Pr (kN)	R.P.M. X1000 (1/min)
			Dg	TOL.								
CFS-170	6.6929	170	167,4	-0,25	2,7	165,7	2,5	4,00	38,50	108,00	33,50	0,5
CFS-175	6.8898	175	172,4	-0,25	2,7	170,7	2,5	4,00	39,40	117,00	32,20	0,4
CFS-180	7.0866	180	177,0	-0,29	3,2	175,2	3,0	5,00	61,20	140,00	67,50	1,0
CFS-185	7.2835	185	182,0	-0,29	3,2	180,2	3,0	5,00	63,90	144,00	66,20	1,0
CFS-190	7.4803	190	187,0	-0,29	3,2	185,1	3,0	5,00	65,90	148,00	64,00	1,0
CFS-195	7.6772	195	192,0	-0,29	3,2	190,1	3,0	5,00	67,50	152,00	62,60	1,0
CFS-200	7.8740	200	197,0	-0,29	3,2	196,0	3,0	5,00	68,40	156,00	61,40	0,5
CFS-210	8.2677	210	207,0	-0,29	3,2	204,9	3,0	5,00	72,00	164,00	58,00	0,5
CFS-220	8.6614	220	217,0	-0,29	3,2	214,8	3,0	5,00	76,30	171,00	55,50	0,4
CFS-230	9.0551	230	227,0	-0,29	3,2	224,7	3,0	5,00	79,80	180,00	53,00	0,3
CFS-240	9.4488	240	237,0	-0,29	3,2	234,6	3,0	5,00	81,70	187,00	51,00	0,3
CFS-250	9.8425	250	247,0	-0,29	3,2	244,5	3,0	5,00	86,50	195,00	49,00	0,3
CFS-260	10.2362	260	255,0	-0,32	4,2	252,4	4,0	7,50	179,00	338,00	168,00	0,4
CFS-265	10.4331	265	260,0	-0,32	4,2	257,4	4,0	7,50	185,20	344,00	165,00	0,4
CFS-270	10.6299	270	265,0	-0,32	4,2	262,3	4,0	7,50	197,70	350,00	162,00	0,4
CFS-280	11.0236	280	275,0	-0,32	4,2	272,2	4,0	7,50	198,70	362,00	155,00	0,4
CFS-285	11.2205	285	280,0	-0,32	4,2	277,2	4,0	7,50	199,50	370,00	151,00	0,3
CFS-290	11.4173	290	285,0	-0,32	4,2	282,1	4,0	7,50	205,30	377,00	148,00	0,3
CFS-300	11.8110	300	295,0	-0,32	4,2	292,1	4,0	7,50	214,20	390,00	145,00	0,3
CFS-305	12.0079	305	300,0	-0,32	4,2	297,1	4,0	7,50	219,40	396,00	142,00	0,3
CFS-310	12.2047	310	305,0	-0,32	4,2	302,0	4,0	7,50	223,10	402,00	139,00	0,3
CFS-320	12.5984	320	315,0	-0,32	4,2	311,9	4,0	7,50	225,30	416,00	137,00	0,3
CFS-330	12.9921	330	325,0	-0,36	4,2	321,8	4,0	7,50	228,60	428,00	132,00	0,2
CFS-340	13.3858	340	335,0	-0,36	4,2	331,7	4,0	7,50	239,30	442,00	129,00	0,2
CFS-350	13.7795	350	345,0	-0,36	4,2	341,6	4,0	7,50	251,20	455,00	123,00	0,2
CFS-360	14.1732	360	355,0	-0,36	4,2	351,5	4,0	7,50	253,10	468,00	120,00	0,2
CFS-370	14.5669	370	365,0	-0,36	4,2	361,5	4,0	7,50	259,20	482,00	117,00	0,2
CFS-380	14.9606	380	375,0	-0,36	4,2	371,4	4,0	7,50	265,80	494,00	115,00	0,2
CFS-390	15.3543	390	385,0	-0,36	4,2	381,3	4,0	7,50	273,90	507,00	112,00	0,2
CFS-400	15.7480	400	395,0	-0,36	4,2	391,2	4,0	7,50	281,10	521,00	109,00	0,1
CFS-420	16.5354	420	415,0	-0,36	4,8	410,0	4,5	12,00	531,00	547,00	133,00	0,3
CFS-460	18.1102	460	455,0	-0,36	4,8	449,5	4,5	12,00	582,00	600,00	126,00	0,2

Hardness: Sizes 4-20, 47-52 HRC; Sizes 21 & Over, 45-50 HRC

Snap Ring, Internal, Metric

Flat Wire.

Once installed in the groove of a housing/bore, the portion of the ring protruding from the groove holds an assembly in place.

CFH Constant Section

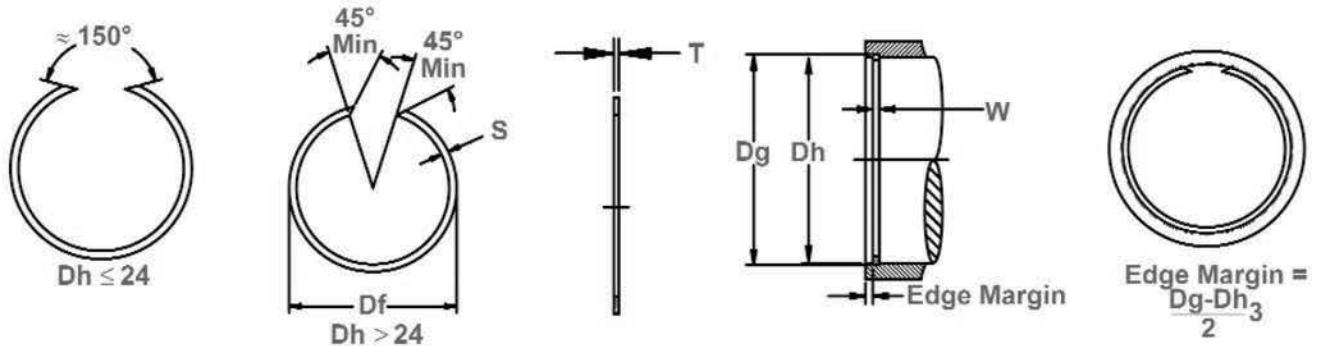

Free Diameter & Ring Dimensions

Housing Diameter & Groove Dimensions

RING SIZE	HOUSING DIAMETER		GROOVE DIMENSIONS			RING DIMENSIONS & WEIGHT				THRUST LOAD	
	Dh DEC	Dh mm	DIAMETER		WIDTH	FREE DIAMETER	THICKNESS	SECTION	WEIGHT kg/1000	Pg (kN)	Pr (kN)
			Dg	TOL.	W min	Df min	T -0,1	S -0,1			
CFH-7	0.2756	7	7.3	+0,09	0.9	7.5	0.8	1.00	0.09	0.55	3.30
CFH-8	0.3150	8	8.3		0.9	8.5	0.8	1.00	0.10	0.65	3.25
CFH-9	0.3543	9	9.3		0.9	9.5	0.8	1.10	0.13	0.70	3.20
CFH-10	0.3937	10	10.4		0.9	10.6	0.8	1.20	0.15	1.05	3.15
CFH-11	0.4331	11	11.4	+0,11	1.1	11.6	1.0	1.30	0.21	1.15	9.15
CFH-12	0.4724	12	12.4		1.1	12.7	1.0	1.30	0.25	1.30	8.90
CFH-13	0.5118	13	13.5		1.1	13.8	1.0	1.30	0.28	1.75	8.80
CFH-14	0.5512	14	14.5		1.1	14.8	1.0	1.30	0.31	1.90	8.20
CFH-15	0.5906	15	15.5		1.1	15.8	1.0	1.30	0.34	2.00	7.70
CFH-16	0.6299	16	16.5		1.3	16.8	1.2	1.75	0.53	2.10	15.50
CFH-17	0.6693	17	17.5	+0,13	1.3	17.8	1.2	1.75	0.55	2.25	15.40
CFH-18	0.7087	18	18.5		1.3	18.9	1.2	1.75	0.68	2.40	15.10
CFH-19	0.7480	19	19.6		1.3	19.9	1.2	1.75	0.72	3.00	14.80
CFH-20	0.7874	20	20.6		1.3	21.0	1.2	1.75	0.76	3.20	14.20
CFH-21	0.8268	21	21.6		1.3	22.0	1.2	1.75	0.79	3.35	13.70
CFH-22	0.8661	22	22.6		1.3	23.0	1.2	1.75	0.81	3.50	13.10
CFH-23	0.9055	23	23.6		1.3	24.0	1.2	1.75	0.88	3.65	12.80
CFH-24	0.9449	24	24.8		1.3	25.2	1.2	1.75	0.90	5.10	12.50
CFH-25	0.9843	25	25.8		1.3	26.2	1.2	1.75	0.91	5.30	12.00
CFH-26	1.0236	26	26.8		1.3	27.2	1.2	1.75	0.98	5.50	11.50
CFH-27	1.0630	27	27.8	+0,16	1.3	28.2	1.2	1.75	1.11	5.70	11.30
CFH-28	1.1024	28	28.8		1.3	29.2	1.2	1.75	1.13	5.95	11.00
CFH-29	1.1417	29	29.8		1.3	30.2	1.2	1.75	1.15	6.15	10.90
CFH-30	1.1811	30	31.0		1.6	31.4	1.5	2.30	2.00	8.00	26.00
CFH-31	1.2205	31	32.0		1.6	32.4	1.5	2.30	2.03	8.25	25.60
CFH-32	1.2598	32	33.0		1.6	33.4	1.5	2.30	2.11	8.50	25.00
CFH-33	1.2992	33	34.0		1.6	34.4	1.5	2.30	2.26	8.75	24.60
CFH-34	1.3386	34	35.0		1.6	35.4	1.5	2.30	2.34	9.00	23.80
CFH-35	1.3780	35	36.0		1.6	36.4	1.5	2.30	2.36	9.30	23.30
CFH-37	1.4567	37	38.2		1.6	38.8	1.5	2.30	2.53	11.75	22.00
CFH-38	1.4961	38	39.2		1.6	39.8	1.5	2.30	2.61	12.15	21.60
CFH-39	1.5354	39	40.2		1.6	40.8	1.5	2.30	2.67	12.40	21.00
CFH-40	1.5748	40	41.2	1.6	41.8	1.5	2.30	2.80	12.70	20.70	
CFH-42	1.6535	42	43.2	1.6	43.8	1.5	2.30	2.92	13.30	19.80	
CFH-43	1.6929	43	44.2	1.6	44.8	1.5	2.30	3.03	13.70	19.60	

Hardness: Sizes 7-20, 47-52HRC; Sizes 21 & Over, 45-50 HRC

CFH Constant Section

Snap Ring, Internal, Metric

Flat Wire.

Once installed in the groove of a housing/bore, the portion of the ring protruding from the groove holds an assembly in place.

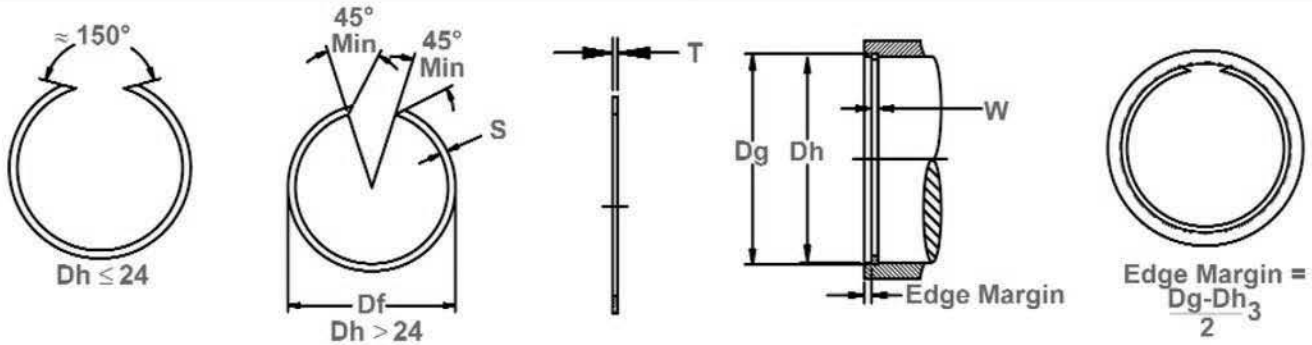

Free Diameter & Ring Dimensions

Housing Diameter & Groove Dimensions

RING SIZE	HOUSING DIAMETER		GROOVE DIMENSIONS			RING DIMENSIONS & WEIGHT				THRUST LOAD	
	Dh DEC	Dh mm	DIAMETER		WIDTH W min	FREE DIAMETER Df min	THICKNESS T -0,1	SECTION S -0,1	WEIGHT kg/1000	Pg (kN)	Pr (kN)
			Dg	TOL.							
CFH-44	1.7323	44	45.2	+0,16	1.6	45.8	1.5	2.30	3.11	14,00	19.30
CFH-45	1.7717	45	46.2		1.6	46.8	1.5	2.30	3.25	14,25	19,00
CFH-46	1.8110	46	47.2		1.6	47.8	1.5	2.30	3.28	14,65	18,40
CFH-47	1.8504	47	48.2		1.6	48.8	1.5	2.30	3.29	14,90	18,10
CFH-48	1.8898	48	49.2		1.6	49.8	1.5	2.30	3.45	15,30	17,60
CFH-50	1.9685	50	51.2		1.6	51.8	1.5	2.30	3.57	15,80	17,20
CFH-52	2.0472	52	53.5		1.6	54.3	1.5	2.30	3.58	20,65	16,30
CFH-53	2.0866	53	54.5		1.6	55.3	1.5	2.30	3.82	21,05	16,10
CFH-55	2.1654	55	56.5	+0,19	1.6	57.3	1.5	2.30	3.93	21,80	15,70
CFH-57	2.2441	57	58.5		1.6	59.3	1.5	2.30	4.12	22,60	15,30
CFH-58	2.2835	58	59.5		1.6	60.3	1.5	2.30	4.13	23,00	15,00
CFH-60	2.3622	60	61.5		1.6	62.3	1.5	2.30	4.28	23,80	14,60
CFH-62	2.4409	62	63.5		1.6	64.3	1.5	2.30	4.42	24,60	14,20
CFH-63	2.4803	63	64.5		1.6	65.3	1.5	2.30	4.50	25,00	13,70
CFH-65	2.5591	65	66.5		1.6	67.3	1.5	2.30	4.72	25,70	13,60
CFH-68	2.6772	68	69.5		1.6	70.3	1.5	2.30	4.90	26,90	12,90
CFH-70	2.7559	70	71.5		1.6	72.3	1.5	2.30	4.93	27,70	12,80
CFH-72	2.8346	72	73.8		2.2	74.6	2.0	2.80	8.49	34,20	35,70
CFH-73	2.8740	73	74.8	2.2	75.6	2.0	2.80	8.52	34,70	35,30	
CFH-74	2.9134	74	75.8	2.2	76.6	2.0	2.80	8.60	35,30	34,80	
CFH-76	2.9921	76	77.8	2.2	78.6	2.0	2.80	8.89	36,20	33,80	
CFH-78	3.0709	78	79.8	2.2	80.6	2.0	2.80	9.05	37,10	32,60	
CFH-79	3.1102	79	80.8	2.2	81.6	2.0	2.80	9.07	37,60	32,00	
CFH-80	3.1496	80	81.8	2.2	82.6	2.0	2.80	9.22	38,00	31,40	
CFH-81	3.1890	81	82.8	2.2	83.6	2.0	2.80	9.31	38,60	31,30	
CFH-82	3.2283	82	83.8	+0,22	2.2	84.6	2.0	2.80	9.45	39,00	30,70
CFH-83	3.2677	83	84.8		2.2	85.6	2.0	2.80	9.63	39,50	30,10
CFH-85	3.3465	85	86.8		2.2	87.6	2.0	2.80	9.81	40,40	29,60
CFH-86	3.3858	86	87.8		2.2	88.6	2.0	2.80	9.91	40,90	29,00
CFH-88	3.4646	88	90.0		2.7	91.0	2.5	3.40	15,40	46,50	65,80
CFH-90	3.5433	90	92.0		2.7	93.0	2.5	3.40	15,60	47,60	63,50
CFH-92	3.6220	92	94.0		2.7	95.0	2.5	3.40	16,60	48,60	62,00
CFH-93	3.6614	93	95.0		2.7	96.0	2.5	3.40	16,80	49,20	61,80
CFH-95	3.7402	95	97.0		2.7	98.0	2.5	3.40	16,90	50,20	59,30
CFH-97	3.8189	97	99.0		2.7	100.0	2.5	3.40	17,10	51,30	58,20

Hardness: Sizes 7-20, 47-52HRC; Sizes 21& Over, 45-50 HRC

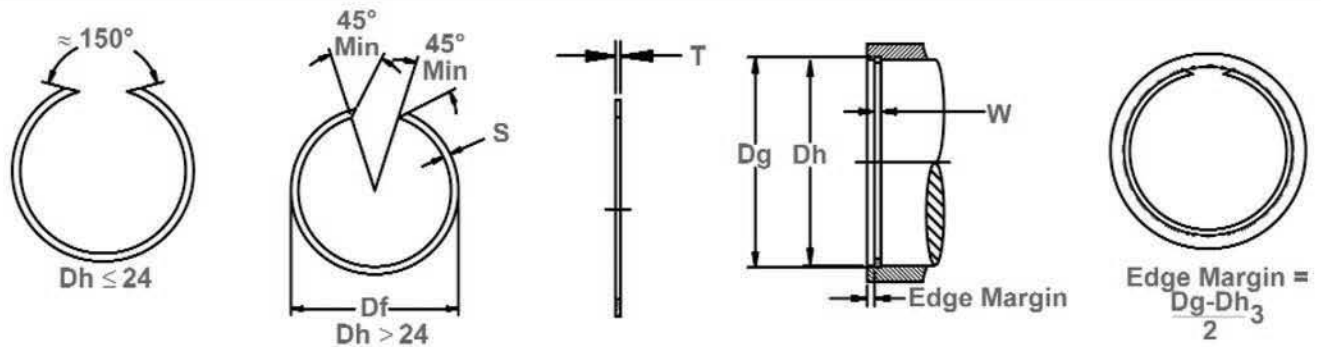

Free Diameter & Ring Dimensions

Housing Diameter & Groove Dimensions

RING SIZE	HOUSING DIAMETER		GROOVE DIMENSIONS			RING DIMENSIONS & WEIGHT				THRUST LOAD	
	Dh DEC	Dh mm	DIAMETER		WIDTH W min	FREE DIAMETER Df min	THICKNESS T -0,1	SECTION S -0,1	WEIGHT kg/1000	Pg (kN)	Pr (kN)
			Dg	TOL.							
CFH-98	3.8583	98	100.0	+0,22	2.7	101.0	2.5	3.40	17.50	51.80	56.60
CFH-100	3.9370	100	102.0		2.7	103.0	2.5	3.40	17.90	52.80	55.50
CFH-102	4.0157	102	104.3		2.7	105.3	2.5	3.40	18.40	62.00	53.60
CFH-103	4.0551	103	105.3		2.7	106.3	2.5	3.40	18.50	62.60	53.20
CFH-105	4.1339	105	107.3		2.7	108.3	2.5	3.40	18.70	63.80	51.80
CFH-107	4.2126	107	109.3		2.7	110.3	2.5	3.40	19.10	65.00	50.70
CFH-108	4.2520	108	110.3		2.7	111.3	2.5	3.40	19.30	65.60	50.50
CFH-110	4.3307	110	112.3		2.7	113.4	2.5	3.40	19.80	66.80	49.00
CFH-112	4.4094	112	114.3		2.7	115.4	2.5	3.40	20.30	68.00	47.00
CFH-113	4.4488	113	115.3		2.7	116.4	2.5	3.40	20.50	68.60	46.50
CFH-115	4.5276	115	117.3	2.7	118.4	2.5	3.40	20.60	69.40	45.50	
CFH-117	4.6063	117	119.3	2.7	120.4	2.5	3.40	20.80	71.00	44.60	
CFH-118	4.6457	118	120.3	2.7	121.4	2.5	3.40	21.10	71.70	44.20	
CFH-120	4.7244	120	122.3	2.7	123.5	2.5	3.40	21.40	72.80	43.30	
CFH-123	4.8425	123	125.3	2.7	126.5	2.5	3.40	22.00	74.70	41.20	
CFH-125	4.9213	125	127.3	2.7	128.5	2.5	3.40	22.50	75.90	40.20	
CFH-127	5.0000	127	129.3	2.7	130.5	2.5	3.40	23.00	77.00	39.80	
CFH-130	5.1181	130	132.3	2.7	133.6	2.5	3.40	23.40	78.90	38.20	
CFH-133	5.2362	133	135.3	2.7	136.6	2.5	3.40	24.40	80.70	36.80	
CFH-135	5.3150	135	137.3	2.7	138.6	2.5	3.40	25.00	81.90	36.60	
CFH-137	5.3937	137	139.3	2.7	140.6	2.5	3.40	25.30	83.00	35.60	
CFH-140	5.5118	140	142.6	+0,25	2.7	144.0	2.5	4.00	29.30	96.10	40.20
CFH-143	5.6299	143	145.6		2.7	147.0	2.5	4.00	30.10	98.10	38.60
CFH-150	5.9055	150	152.6		2.7	154.1	2.5	4.00	31.90	102.00	36.20
CFH-153	6.0236	153	155.6		2.7	157.1	2.5	4.00	32.60	104.00	35.60
CFH-160	6.2992	160	162.6		2.7	164.2	2.5	4.00	34.40	108.00	34.60
CFH-163	6.4173	163	165.6		2.7	167.2	2.5	4.00	34.60	111.00	33.50
CFH-165	6.4961	165	167.6		2.7	169.2	2.5	4.00	34.90	113.00	32.80
CFH-170	6.6929	170	172.6		2.7	174.3	2.5	4.00	36.20	116.00	32.00
CFH-173	6.8110	173	175.6		2.7	177.3	2.5	4.00	37.10	118.00	32.00
CFH-175	6.8898	175	177.6		2.7	179.3	2.5	4.00	37.30	119.00	31.40
CFH-180	7.0866	180	182.6	+0,29	2.7	184.5	2.5	4.00	38.30	123.00	30.80
CFH-183	7.2047	183	185.6		2.7	187.5	2.5	4.00	41.00	125.00	30.00
CFH-190	7.4803	190	193.0		3.2	194.9	3.0	5.00	61.30	150.00	62.80
CFH-195	7.6772	195	198.0		3.2	199.9	3.0	5.00	61.60	154.00	61.50

Hardness: Sizes 7-20, 47-52HRC; Sizes 21 & Over, 45-50 HRC



CFH Constant Section

Snap Ring, Internal, Metric

Flat Wire.

Once installed in the groove of a housing/bore, the portion of the ring protruding from the groove holds an assembly in place.

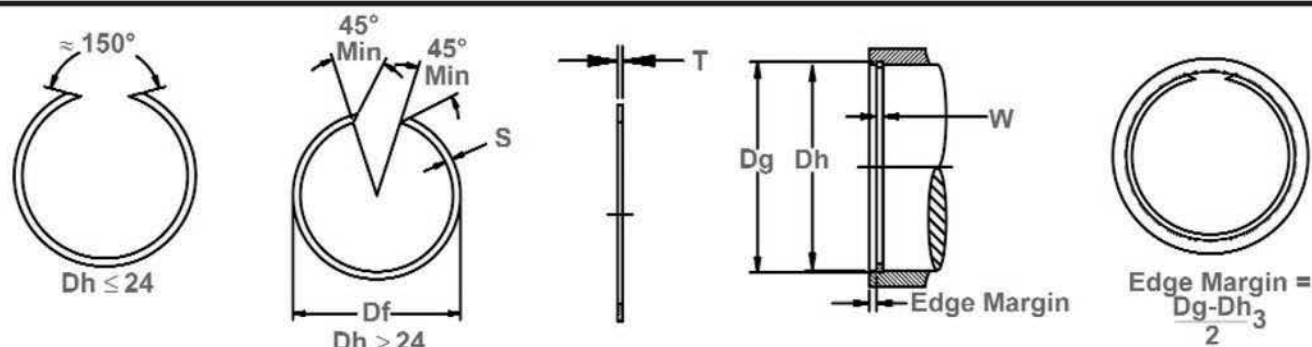

Free Diameter & Ring Dimensions

Housing Diameter & Groove Dimensions

RING SIZE	HOUSING DIAMETER		GROOVE DIMENSIONS			RING DIMENSIONS & WEIGHT				THRUST LOAD	
	Dh DEC	Dh mm	DIAMETER		WIDTH	FREE DIAMETER	THICKNESS	SECTION	WEIGHT	Pg (kN)	Pr (kN)
			Dg	TOL.							
CFH-200	7.8740	200	203.0	+0,29	3,2	205,0	3,0	5,00	64,50	158,00	59,00
CFH-205	8.0709	205	208,0		3,2	210,0	3,0	5,00	66,40	162,00	57,80
CFH-210	8.2677	210	213,0		3,2	215,1	3,0	5,00	68,80	166,00	56,80
CFH-215	8.4646	215	218,0		3,2	220,1	3,0	5,00	69,50	169,00	55,50
CFH-220	8.6614	220	223,0		3,2	225,2	3,0	5,00	72,40	173,00	54,40
CFH-225	8.8583	225	228,0		3,2	230,2	3,0	5,00	72,90	177,00	53,30
CFH-230	9.0551	230	233,0		3,2	235,3	3,0	5,00	75,20	181,00	52,00
CFH-240	9.4488	240	243,0		3,2	245,4	3,0	5,00	80,90	189,00	49,60
CFH-250	9.8425	250	253,0	3,2	255,5	3,0	5,00	84,20	197,00	48,50	
CFH-260	10.2362	260	265,0	+0,32	4,2	267,6	4,0	7,50	165,00	343,00	162,00
CFH-270	10.6299	270	275,0		4,2	277,7	4,0	7,50	174,00	356,00	157,00
CFH-280	11.0236	280	285,0		4,2	287,8	4,0	7,50	184,00	369,00	152,00
CFH-290	11.4173	290	295,0		4,2	297,9	4,0	7,50	190,00	382,00	144,00
CFH-300	11.8110	300	305,0		4,2	307,9	4,0	7,50	196,00	395,00	140,00
CFH-310	12.2047	310	315,0		4,2	318,0	4,0	7,50	200,00	408,00	136,00
CFH-320	12.5984	320	325,0		4,2	328,1	4,0	7,50	203,00	422,00	132,00
CFH-325	12.7953	325	330,0		4,2	333,1	4,0	7,50	206,00	428,00	129,00
CFH-330	12.9921	330	335,0	+0,36	4,2	338,2	4,0	7,50	209,00	435,00	126,00
CFH-340	13.3858	340	345,0		4,2	348,3	4,0	7,50	219,00	448,00	123,00
CFH-350	13.7795	350	355,0		4,2	358,4	4,0	7,50	229,00	452,00	121,00
CFH-355	13.9764	355	360,0		4,2	363,4	4,0	7,50	231,00	467,00	121,00
CFH-360	14.1732	360	365,0		4,2	368,5	4,0	7,50	233,00	487,00	119,00
CFH-370	14.5669	370	375,0		4,2	378,5	4,0	7,50	236,00	493,00	116,00
CFH-375	14.7638	375	380,0		4,2	383,5	4,0	7,50	240,00	500,00	112,00
CFH-380	14.9606	380	385,0		4,2	388,6	4,0	7,50	242,00	513,00	111,00
CFH-390	15.3543	390	395,0	+0,40	4,2	398,7	4,0	7,50	253,00	520,00	110,00
CFH-395	15.5512	395	400,0		4,2	403,7	4,0	7,50	257,00	526,00	109,00
CFH-400	15.7480	400	405,0		4,2	408,9	4,0	7,50	260,00	529,00	106,00
CFH-410	16.1417	410	415,0		4,2	419,0	4,0	7,50	266,00	546,00	105,00
CFH-420	16.3386	415	420,0		4,2	424,0	4,0	7,50	273,00	552,00	104,00
CFH-420	16.5354	420	425,0		4,2	429,1	4,0	7,50	277,00	553,00	101,00
CFH-430	16.9291	430	435,0		4,2	439,2	4,0	7,50	285,00	565,00	100,00
CFH-440	17.3228	440	445,0		4,2	449,3	4,0	7,50	294,00	578,00	98,00

Hardness: Sizes 7-20, 47-52HRC; Sizes 21 & Over, 45-50 HRC

For alternate cutoff styles, contact Rotor Clip Technical Sales at 1-800-557-6867 (E-mail: tech@rotorclip.com)

Snap Ring, External, Metric

For Bearings.

Once installed in the groove of a shaft, the portion of the ring protruding from the groove holds an assembly in place.

CBS Constant Section

DIN 5417

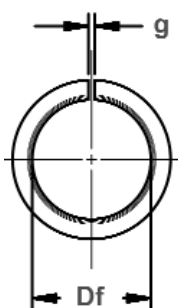

Free Diameter & Ring Dimensions
With Section B-B

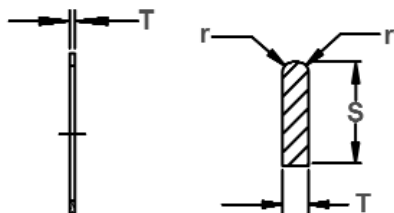

Shaft Diameter &
Groove Dimensions

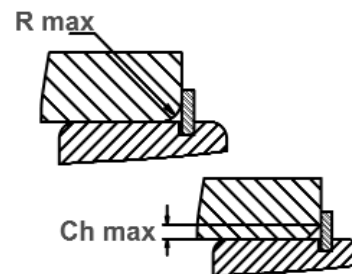
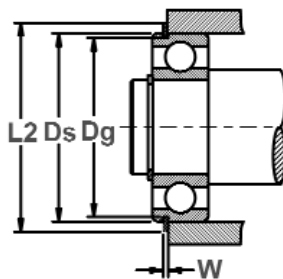

Maximum Corner
Radius & Chamfer

RING SIZE	SHAFT DIAMETER		GROOVE DIMENSIONS				RING DIMENSIONS & WEIGHT											SUPPLEMENTARY DATA					
	Ds DEC	Ds mm	DIAMETER		WIDTH		THICKNESS		SECTION		FREE DIAMETER		GAP	RADIUS	WEIGHT	L2	Pg	Pr	R max Ch max	Pr kN	R.P.M. X1000 (1/min)		
			Dg	TOL.	W	TOL.	T	TOL.	S	TOL.	Df	TOL.										g	r min.
CBS-30	1.1811	30	28,17		1,35		1,12		3,25		27,4		3	0,4	2,8	34,7	13,7	16,6	2,0	2,91	16,0		
CBS-32	1.2598	32	30,15		1,35		1,12		3,25		29,4		3	0,4	3,0	36,7	14,6	14,6	2,0	2,57	13,0		
CBS-35	1.3780	35	33,17		1,35		1,12		3,25		32,4	+0,4	3	0,4	3,2	39,7	16,0	13,4	2,0	2,42	11,0		
CBS-37	1.4567	37	34,77		1,35		1,12		3,25		34,0		3	0,4	3,4	41,3	20,7	13,6	2,0	2,45	10,0		
CBS-40	1.5748	40	38,10		1,35		1,12		3,25		37,3		3	0,4	3,6	44,6	19,3	13,5	2,0	2,50	8,0		
CBS-42	1.6535	42	39,75	-0,25	1,35		1,12		3,25		38,9		3	0,4	3,8	46,3	23,5	12,9	2,0	2,39	7,0		
CBS-44	1.7323	44	41,75		1,35		1,12		3,25		40,9		3	0,4	4,0	48,3	24,6	12,4	2,0	2,29	7,0		
CBS-47	1.8504	47	44,60		1,35		1,12		4,04		43,7	+0,5	4	0,4	5,3	52,7	28,8	12,1	2,0	2,29	7,0		
CBS-50	1.9685	50	47,60		1,35		1,12		4,04		46,7		4	0,4	5,8	55,7	30,6	13,3	2,0	2,60	6,0		
CBS-52	2.0472	52	49,73		1,35		1,12		4,04		48,8		4	0,4	5,9	57,9	31,6	12,8	2,5	2,01	6,0		
CBS-55	2.1654	55	52,60		1,35		1,12		4,04		51,7		4	0,4	6,2	60,7	33,8	11,8	2,5	1,90	5,0		
CBS-56	2.2047	56	53,60		1,35		1,12		4,04		52,4		4	0,4	6,5	61,7	34,5	12,1	2,5	1,95	5,0		
CBS-58	2.2835	58	55,60		1,35	+0,3	1,12	-0,1	4,04	-0,15	54,4		4	0,4	6,7	63,7	35,6	11,5	2,5	1,89	5,0		
CBS-62	2.4409	62	59,61		1,90		1,70		4,85		58,2		4	0,6	10,5	67,7	38,1	37,6	2,5	6,18	5,0		
CBS-65	2.5591	65	62,60		1,90		1,70		4,85		61,2		4	0,6	11,0	70,7	40,0	34,9	2,5	5,89	4,0		
CBS-68	2.6772	68	64,82		1,90		1,70		4,85		63,4		5	0,6	12,6	74,6	55,5	40,9	2,5	7,06	4,0		
CBS-72	2.8346	72	68,81		1,90		1,70		4,85		67,4	+0,8	5	0,6	14,7	78,6	59,0	38,9	2,5	6,71	4,0		
CBS-75	2.9528	75	71,83		1,90		1,70		4,85		70,4		5	0,6	15,3	81,6	61,5	36,6	2,5	6,46	3,0		
CBS-80	3.1496	80	76,81		1,90		1,70		4,85		75,4		5	0,6	16,3	86,6	65,7	34,8	3,0	5,25	3,0		
CBS-85	3.3465	85	81,81	-0,50	1,90		1,70		4,85		80,4		5	0,6	17,5	91,6	70,0	33,5	3,0	5,16	3,0		
CBS-90	3.5433	90	86,79		2,70		2,46		4,85		85,4		5	0,7	26,6	96,5	74,0	93,9	3,0	14,80	2,0		
CBS-95	3.7402	95	91,82		2,70		2,46		4,85		90,4		5	0,7	28,2	101,6	76,3	86,8	3,5	12,00	2,0		
CBS-100	3.9370	100	96,80		2,70		2,46		4,85		95,2		5	0,7	29,2	106,5	82,5	80,8	3,5	11,40	2,0		
CBS-110	4.3307	110	106,81		2,70		2,46		4,85		105,2	+1,0	5	0,7	32,8	116,6	90,7	71,2	3,5	10,40	1,0		
CBS-115	4.5276	115	111,81		2,70		2,46		4,85		110,2		5	0,7	34,4	121,6	97,7	66,6	3,5	10,00	1,0		
CBS-120	4.7244	120	115,21		3,10		2,82		7,21		113,6		7	0,7	60,6	129,7	143,0	140,0	3,5	21,30	2,0		
CBS-125	4.9213	125	120,22		3,10		2,82		7,21		118,6		7	0,7	63,0	134,7	155,0	132,0	4,0	17,90	2,0		

Snap Ring, External, Metric

Round Wire.

Once installed in the groove of a shaft, the portion of the ring protruding from the groove holds an assembly in place.

CRS Constant Section DIN 7993

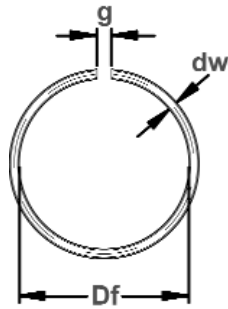

Free Diameter & Ring Dimensions

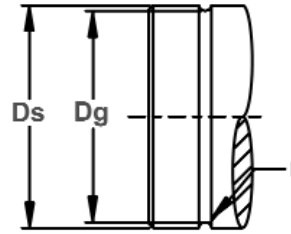

Shaft Diameter & Groove Dimensions

RING SIZE	SHAFT DIAMETER		GROOVE DIMENSIONS			RING DIMENSIONS & WEIGHT					R.P.M. X1000 (1/min)
	Ds DEC	Ds mm	DIAMETER		RADIUS	WIRE DIA.	FREE DIAMETER		GAP	WEIGHT	
			Dg	TOL.	r	dw	Df	TOL.	g	kg/1000	
CRS-4	0.1575	4	3,2	±0,05	0,5	0,8	3,1	-0,2	1	0,044	175
CRS-5	0.1969	5	4,2		0,5	0,8	4,1		1	0,057	112
CRS-6	0.2362	6	5,2		0,5	0,8	5,1		1	0,069	77
CRS-7	0.2756	7	6,2		0,5	0,8	6,1	-0,3	2	0,077	57
CRS-8	0.3150	8	7,2		0,5	0,8	7,1		2	0,090	44
CRS-10	0.3937	10	9,2		0,5	0,8	9,1	-0,4	2	0,115	28
CRS-12	0.4724	12	11,0		0,6	1,0	10,8		3	0,210	24
CRS-14	0.5512	14	13,0		0,6	1,0	12,8		3	0,250	18
CRS-16	0.6299	16	14,4		0,9	1,6	14,2		3	0,740	22
CRS-18	0.7087	18	16,4		0,9	1,6	16,2		3	0,830	17
CRS-20	0.7874	20	18,0	1,1	2,0	17,7	3		1,450	18	
CRS-22	0.8661	22	20,0	1,1	2,0	19,7	3		1,600	15	
CRS-24	0.9449	24	22,0	1,1	2,0	21,7	3		1,780	12	
CRS-25	0.9843	25	23,0	±0,10	1,1	2,0	22,7	-0,5	3	1,840	11
CRS-26	1.0236	26	24,0		1,1	2,0	23,7		3	1,910	10
CRS-28	1.1024	28	26,0		1,1	2,0	25,7		3	2,070	9
CRS-30	1.1811	30	28,0		1,1	2,0	27,7	3	2,220	8	
CRS-32	1.2598	32	29,5		1,4	2,5	29,1	-0,6	4	3,670	9
CRS-35	1.3780	35	32,5		1,4	2,5	32,1		4	3,980	7
CRS-38	1.4961	38	35,5		1,4	2,5	35,1	4	4,400	6	
CRS-40	1.5748	40	37,5		1,4	2,5	37,1	4	4,640	6	
CRS-42	1.6535	42	39,5		1,4	2,5	39,0	-0,8	4	4,870	5
CRS-45	1.7717	45	42,5		1,4	2,5	42,0		4	5,230	4
CRS-48	1.8898	48	45,5	1,4	2,5	45,0	4		5,600	4	
CRS-50	1.9685	50	47,5	1,4	2,5	47,0	4		5,830	4	
CRS-55	2.1654	55	51,8	1,8	3,2	51,1	4		10,510	4	
CRS-60	2.3622	60	56,8	1,8	3,2	56,1	4		11,500	3	
CRS-65	2.5591	65	61,8	1,8	3,2	61,1	4		12,490	3	
CRS-70	2.7559	70	66,8	1,8	3,2	66,0	-1,0		5	13,400	2
CRS-75	2.9528	75	71,8	1,8	3,2	71,0		5	14,390	2	
CRS-80	3.1496	80	76,8	1,8	3,2	76,0		5	15,380	2	
CRS-85	3.3465	85	81,8	±0,15	1,8	3,2	81,0	-1,2	5	16,380	2
CRS-90	3.5433	90	86,8		1,8	3,2	86,0		5	17,370	1
CRS-95	3.7402	95	91,8		1,8	3,2	91,0		5	18,360	1
CRS-100	3.9370	100	96,8		1,8	3,2	95,8	-1,2	5	19,310	1
CRS-105	4.1339	105	101,8		1,8	3,2	100,8		5	20,300	1
CRS-110	4.3307	110	106,8		1,8	3,2	105,8		5	21,290	1
CRS-115	4.5276	115	111,8		1,8	3,2	110,8		5	22,290	1
CRS-120	4.7244	120	116,8		1,8	3,2	115,8		5	23,280	1
CRS-125	4.9213	125	121,8		1,8	3,2	120,8		5	24,270	1

For alternate cutoff styles, contact Rotor Clip Technical Sales at 1-800-557-6867 (E-mail: tech@rotorclip.com)



For the most up-to-date specifications, online ordering, quotations & sample orders, visit www.rotorclip.com

Snap Ring, Internal, Metric

Round Wire.

Once installed in the groove of a housing/bore, the portion of the ring protruding from the groove holds an assembly in place.

CRH Constant Section

DIN 7993

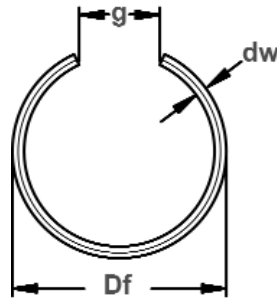

Free Diameter & Ring Dimensions

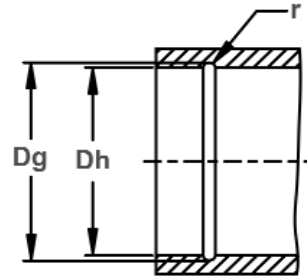

Housing Diameter & Groove Dimensions

RING SIZE	HOUSING DIAMETER		GROOVE DIMENSIONS			RING DIMENSIONS & WEIGHT				
	Dh DEC	Dh mm	DIAMETER		RADIUS	WIRE DIA.	FREE DIAMETER		GAP	WEIGHT
			Dg	TOL.	r	dw	Df	TOL.	(g)	kg/1000
CRH-7	0.2756	7	7,80	±0,05	0,5	0,8	7,9	+0,3	4	0,071
CRH-8	0.3150	8	8,80		0,5	0,8	8,9		4	0,083
CRH-10	0.3937	10	10,80		0,5	0,8	10,9		4	0,108
CRH-12	0.4724	12	13,00		0,6	1,0	13,2		6	0,196
CRH-14	0.5512	14	15,00	±0,4	0,6	1,0	15,2	+0,4	6	0,234
CRH-16	0.6299	16	17,60		0,9	1,6	17,8		8	0,706
CRH-18	0.7087	18	19,60		0,9	1,6	19,8		8	0,804
CRH-20	0.7874	20	22,00		1,1	2,0	22,3		10	1,320
CRH-22	0.8661	22	24,00	±0,5	1,1	2,0	24,3	+0,5	10	1,470
CRH-24	0.9449	24	26,00		1,1	2,0	26,3		10	1,630
CRH-25	0.9843	25	27,00		1,1	2,0	27,3		10	1,700
CRH-26	1.0236	26	28,00		1,1	2,0	28,3		10	1,790
CRH-28	1.1024	28	30,00	±0,10	1,1	2,0	30,3	+0,6	10	1,940
CRH-30	1.1811	30	32,00		1,1	2,0	32,3		12	3,470
CRH-32	1.2598	32	34,50		1,4	2,5	34,9		12	3,850
CRH-35	1.3780	35	37,50		1,4	2,5	37,9		12	4,200
CRH-38	1.4961	38	40,50	±0,15	1,4	2,5	40,9	+0,8	12	4,430
CRH-40	1.5748	40	42,50		1,4	2,5	42,9		16	4,540
CRH-42	1.6535	42	44,50		1,4	2,5	45,0		16	4,890
CRH-45	1.7717	45	47,50		1,4	2,5	48,8		16	5,240
CRH-48	1.8898	48	50,50	±0,15	1,4	2,5	51,0	+1,0	16	5,510
CRH-50	1.9685	50	52,50		1,4	2,5	53,0		20	9,770
CRH-55	2.1654	55	58,20		1,8	3,2	58,9		20	10,760
CRH-60	2.3622	60	63,20		1,8	3,2	63,9		20	11,750
CRH-65	2.5591	65	68,20	±0,15	1,8	3,2	68,9	+1,0	20	11,750
CRH-70	2.7559	70	73,20		1,8	3,2	74,0		25	12,440
CRH-75	2.9528	75	78,20		1,8	3,2	79,0		25	13,430
CRH-80	3.1496	80	83,20		1,8	3,2	84,0		25	14,420
CRH-85	3.3465	85	88,20	±0,15	1,8	3,2	89,0	+1,2	25	15,410
CRH-90	3.5433	90	93,20		1,8	3,2	94,0		25	16,400
CRH-95	3.7402	95	98,20		1,8	3,2	99,0		25	17,390
CRH-100	3.9370	100	103,20		1,8	3,2	104,2		32	17,980
CRH-105	4.1339	105	108,20	±0,15	1,8	3,2	109,2	+1,2	32	18,980
CRH-110	4.3307	110	113,20		1,8	3,2	114,2		32	19,970
CRH-115	4.5276	115	118,20		1,8	3,2	119,2		32	20,960
CRH-120	4.7244	120	123,20		1,8	3,2	124,2		32	21,950
CRH-125	4.9213	125	128,20	1,8	3,2	129,2	32	22,940		

For alternate cutoff styles, contact Rotor Clip Technical Sales at 1-800-557-6867 (E-mail: tech@rotorclip.com)

Constant Section Ring Optional **Cutoff Styles**®

The following cutoff styles represent "specials" requested by the marketplace over a period of many years. One of these configurations may suit your application requirements and may be substituted for any size ring listed in the catalog specification pages. Or, we can make any configuration your application requires. For more information, contact Rotor Clip technical sales: 1-800-557-6867, E-mail: tech@rotorclip.com.

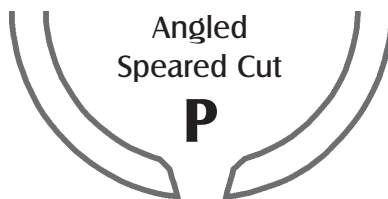
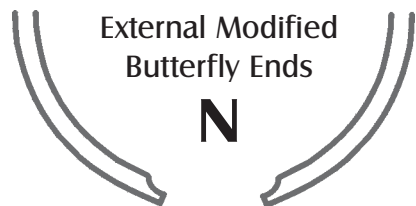
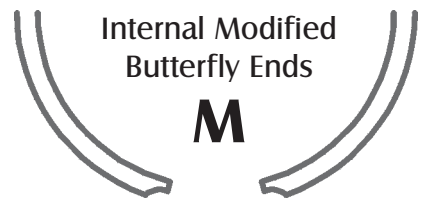
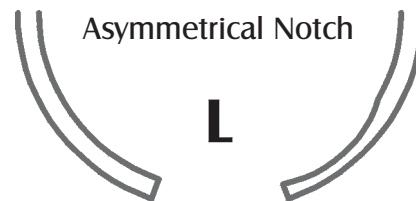
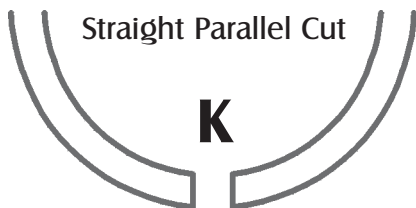
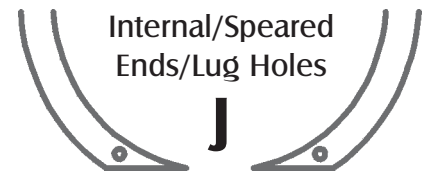
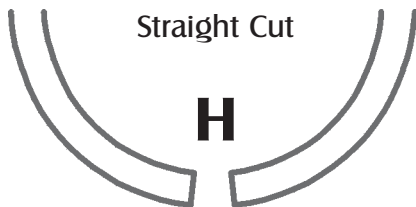
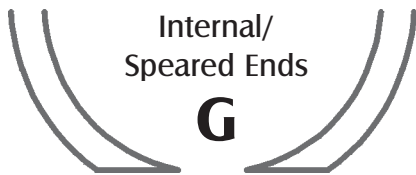
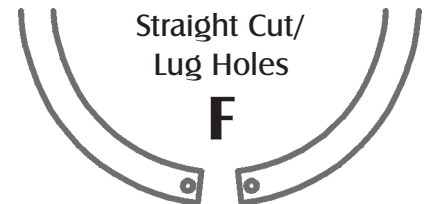
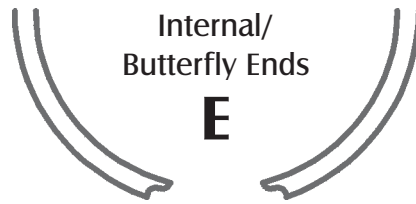
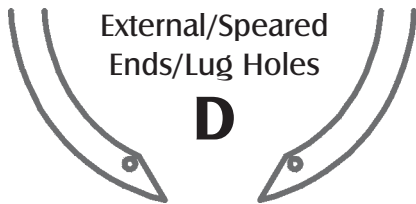
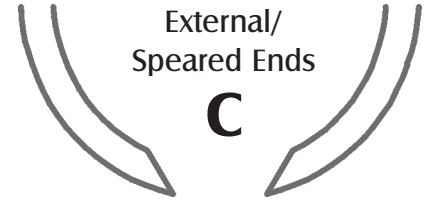
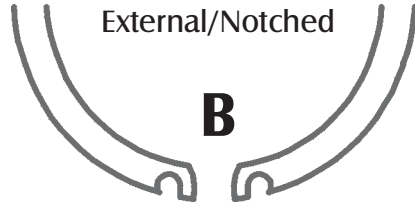
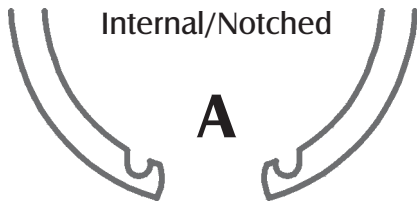



KL Spiral Housing Rings

Internal, Light Duty

These single-turn retaining rings are ideal for light-duty applications, or where axial positioning is the primary function.

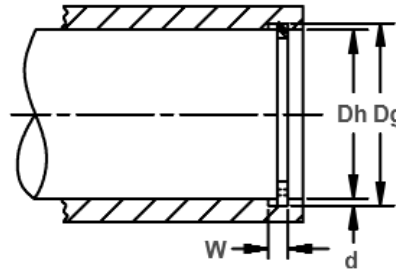
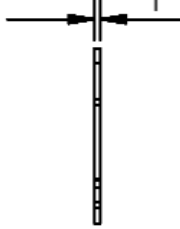
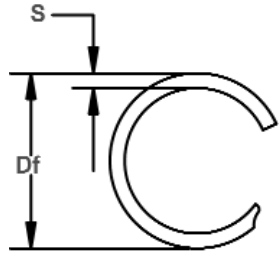

Free Diameter & Ring Measurements

Housing Diameter & Groove Dimensions

RING NO.	HOUSING DIAMETER (In.)	GROOVE SIZE					RING SIZE					THRUST LOAD (lbs.)			
		DIAMETER		WIDTH		DEPTH	FREE DIAMETER			THICKNESS		SECTION		RING Safety factor of 3	GROOVE Safety factor of 2
		Dg	Tol.	W	Tol.	d	Df	Tol.	T	Tol.	S	Tol.			
KL-50	.500	.528		.022		.014	.531		.018		.045		1300	500	
KL-56	.562	.590	+ .002	.022		.014	.593		.018		.045		1460	560	
KL-62	.625	.653	- .002	.022		.014	.656		.018		.045		1630	620	
KL-68	.687	.715		.022		.014	.719		.018		.045		1790	680	
KL-75	.750	.779		.022		.015	.783	+ .013	.018		.045		1950	800	
KL-81	.812	.854		.026		.021	.862		.021		.065		2460	1210	
KL-87	.875	.917	+ .003	.026	+ .002	.021	.926		.021		.065		2660	1300	
KL-93	.937	.979	- .003	.026	- .000	.021	.989		.021		.065		2840	1390	
KL-100	1.000	1.042		.026		.021	1.052		.021		.065		3040	1480	
KL-106	1.062	1.106		.031		.022	1.117		.025		.088		3500	1650	
KL-112	1.125	1.169		.031		.022	1.180		.025		.088		3710	1750	
KL-118	1.187	1.231		.031		.022	1.242		.025		.088		3920	1850	
KL-125	1.250	1.294	+ .004	.031		.022	1.307	+ .015	.025		.088		4120	1940	
KL-131	1.312	1.356	- .004	.031		.022	1.369	- .000	.025		.088		4330	2040	
KL-137	1.375	1.419		.031		.022	1.433		.025		.088		4540	2140	
KL-143	1.437	1.481		.031		.022	1.496		.025		.088		4740	2240	
KL-150	1.500	1.544		.031		.022	1.559		.025		.088		4950	2330	
KL-156	1.562	1.619		.039		.029	1.637		.031		.118	+ .004	6390	3200	
KL-162	1.625	1.682		.039		.029	1.701		.031		.118	- .004	6650	3330	
KL-168	1.687	1.744		.039		.029	1.763		.031		.118		6900	3460	
KL-175	1.750	1.807	+ .005	.039		.029	1.827	+ .020	.031		.118		7160	3590	
KL-181	1.812	1.869	- .005	.039		.029	1.890	- .000	.031		.118		7410	3710	
KL-187	1.875	1.932		.039		.029	1.953		.031		.118		7670	3840	
KL-193	1.937	1.994		.039		.029	2.016		.031		.118		7920	3970	
KL-200	2.000	2.057		.039		.029	2.079		.031		.118		8180	4100	
KL-206	2.062	2.138		.039		.038	2.162		.031		.158		8430	5540	
KL-212	2.125	2.201		.039	+ .003	.038	2.226		.031	+ .002	.158		8690	5710	
KL-218	2.187	2.263		.039	- .000	.038	2.289		.031	- .002	.158		8950	5870	
KL-225	2.250	2.326		.039		.038	2.352		.031		.158		9200	6040	
KL-231	2.312	2.388		.039		.038	2.415		.031		.158		9460	6210	
KL-237	2.375	2.451		.039		.038	2.478		.031		.158		9720	6380	
KL-243	2.437	2.513	+ .006	.039		.038	2.541	+ .025	.031		.158		9970	6550	
KL-250	2.500	2.576	- .006	.039		.038	2.605	- .000	.031		.158		10230	6720	
KL-256	2.562	2.638		.039		.038	2.667		.031		.158		10480	6880	
KL-262	2.625	2.701		.039		.038	2.731		.031		.158		10740	7050	
KL-268	2.687	2.763		.039		.038	2.794		.031		.158		10990	7220	
KL-275	2.750	2.826		.039		.038	2.857		.031		.158		11250	7390	
KL-281	2.812	2.888		.039		.038	2.920		.031		.158		11500	7550	
KL-287	2.875	2.951		.039		.038	2.983		.031		.158		11760	7720	
KL-293	2.937	3.013		.039		.038	3.046		.031		.158		12010	7890	
KL-300	3.000	3.076		.039		.038	3.110		.031		.158		12270	8060	

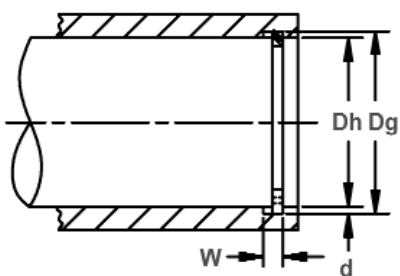
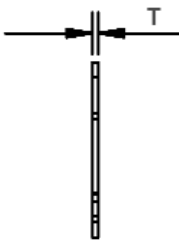
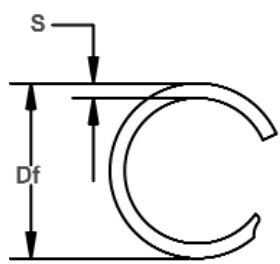

Free Diameter & Ring Measurements

Housing Diameter & Groove Dimensions

RING NO.	HOUSING DIAMETER		GROOVE SIZE				RING SIZE				THRUST LOAD (lbs.)			
	Dh	Diameter	WIDTH		DEPTH	FREE DIAMETER		THICKNESS		SECTION		RING Safety factor of 3	GROOVE Safety factor of 2	
		(In.)	Dg	Tol.		Tol.	Tol.	Tol.	Tol.	Tol.	S			Tol.
KL-306	3.062	3.154	+.006 -.006	.044	+.003 -.000	.046	3.188	+.030 -.000	.039	+.002 -.002	.188	+.005 -.005	15760	9960
KL-312	3.125	3.217		.044		.046	3.251		.039		.188		16080	10160
KL-318	3.187	3.279		.044		.046	3.314		.039		.188		16400	10360
KL-325	3.250	3.342		.044		.046	3.377		.039		.188		16720	10570
KL-331	3.312	3.404		.044		.046	3.440		.039		.188		17040	10770
KL-337	3.375	3.467		.044		.046	3.504		.039		.188		17370	10970
KL-343	3.437	3.529		.044		.046	3.566		.039		.188		17690	11180
KL-350	3.500	3.592		.044		.046	3.630		.039		.188		17690	11180
KL-356	3.562	3.654		.044		.046	3.692		.039		.188		18010	11380
KL-362	3.625	3.717		.044		.046	3.756		.039		.188		18330	11580
KL-368	3.687	3.779		.044		.046	3.819		.039		.188		18650	11790
KL-375	3.750	3.842		.044		.046	3.882		.039		.188		18970	11990
KL-381	3.812	3.904		.044		.046	3.945		.039		.188		19300	12190
KL-387	3.875	3.967		.044		.046	4.009		.039		.188		19620	12400
KL-393	3.937	4.029		.044		.046	4.071		.039		.188		19940	12600
KL-400	4.000	4.092		.044		.046	4.135		.039		.188		20260	12800
KL-412	4.125	4.235		.052		+.004 -.000	.055		4.279		+.035 -.000		.046	+.002 -.002
KL-425	4.250	4.360	.052	.055	4.405		.046	.225	20800	13200				
KL-437	4.375	4.485	.052	.055	4.531		.046	.225	21100	13400				
KL-450	4.500	4.610	.052	.055	4.658		.046	.225	21400	13600				
KL-462	4.625	4.735	.052	.055	4.784		.046	.225	21700	13800				
KL-475	4.750	4.860	.052	.055	4.910		.046	.225	22000	14000				
KL-487	4.875	4.985	.052	.055	5.036		.046	.225	22300	14200				
KL-500	5.000	5.110	.052	.066	5.163		.061	.225	22600	14400				
KL-525	5.250	5.381	.067	.069	5.435		.061	.225	22900	14600				
KL-550	5.500	5.638	.067	.072	5.694		.061	.225	23200	14800				
KL-575	5.750	5.894	.067	.075	5.953		.061	.225	23500	15000				
KL-600	6.000	6.150	.067	.078	6.212		.061	.225	23800	15200				
KL-625	6.250	6.406	.067	.082	6.470		.061	.225	24100	15400				
KL-650	6.500	6.663	.067	.085	6.730		.061	.225	24400	15600				
KL-675	6.750	6.919	.067	.088	6.988		.061	.225	24700	15800				
KL-700	7.000	7.175	.067	.091	7.247		.061	.225	25000	16000				
KL-725	7.250	7.431	.067	.094	7.505		.061	.225	25300	16200				
KL-750	7.500	7.688	.067	.097	7.765	.061	.225	25600	16400					
KL-775	7.750	7.944	.067	.100	8.023	.061	.225	25900	16600					
KL-800	8.000	8.200	.067	.103	8.282	.061	.225	26200	16800					
KL-825	8.250	8.456	.067	.107	8.541	.061	.225	26500	17000					
KL-850	8.500	8.713	.067	.110	8.800	.061	.225	26800	17200					
KL-875	8.750	8.969	.082	+.005 -.000	.113	9.059	+.070 -.000	.076	+.004 -.008	.345	27100	17400		
KL-900	9.000	9.225	.082		.116	9.317		.076		.345	27400	17600		
KL-925	9.250	9.481	.082		.119	9.576		.076		.345	27700	17800		
KL-950	9.500	9.738	.082		.122	9.835		.076		.345	28000	18000		
KL-975	9.750	9.994	.082		.125	10.094		.076		.345	28300	18200		
KL-1000	10.000	10.250	.082		.125	10.353		.076		.345	28600	18400		

CL Spiral Shaft Rings

External, Light Duty

These single-turn retaining rings are ideal for light-duty applications, or where axial positioning is the primary function.

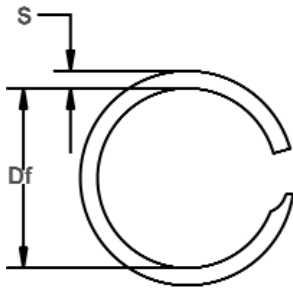

Free Diameter & Ring Measurements

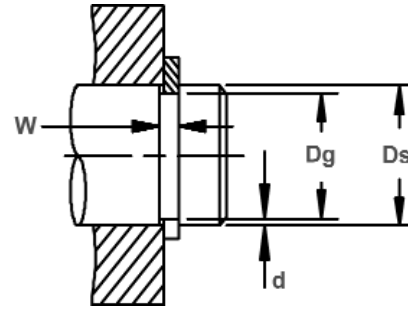
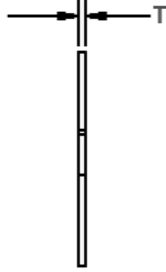

Shaft Diameter & Groove Dimensions

RING NO.	SHAFT DIAMETER (In.)	GROOVE SIZE					RING SIZE					THURST LOAD (lbs.)		
		DIAMETER		WIDTH		DEPTH	FREE DIAMETER		THICKNESS		SECTION		RING Safety factor of 3	GROOVE Safety factor of 2
		Ds	Dg Tol.	W Tol.	d	Df Tol.	T Tol.	S Tol.	Pr	Pg				
CL-50	.500	.472		.022	.014	.467		.018	.045	1300	500			
CL-56	.562	.534	+ .002	.022	.014	.529		.018	.045	1460	560			
CL-62	.625	.597	- .002	.022	.014	.591		.018	.045	1630	620			
CL-68	.687	.659		.022	.014	.652	+ .000	.018	.045	1790	680			
CL-75	.750	.722		.022	.014	.715	- .013	.018	.045	1950	740			
CL-81	.812	.770		.026	.021	.762		.021	.065	2460	1210			
CL-87	.875	.833	+ .003	.026	.021	.825		.021	.065	2660	1300			
CL-93	.937	.895	- .003	.026	.021	.886		.021	.065	2840	1390			
CL-100	1.000	.958		.026	.021	.949		.021	.065	3040	1480			
CL-106	1.062	1.018		.031	.022	1.008		.025	.088	3500	1650			
CL-112	1.125	1.081		.031	.022	1.071		.025	.088	3710	1750			
CL-118	1.187	1.143		.031	.022	1.132		.025	.088	3920	1850			
CL-125	1.250	1.206	+ .004	.031	.022	1.194	+ .000	.025	.088	4120	1940			
CL-131	1.312	1.268	- .004	.031	.022	1.255	- .015	.025	.088	4330	2040			
CL-137	1.375	1.331		.031	.022	1.318		.025	.088	4540	2140			
CL-143	1.437	1.393		.031	.022	1.379		.025	.088	4740	2240			
CL-150	1.500	1.456		.031	.022	1.442		.025	.088	4950	2330			
CL-156	1.562	1.505		.039	.029	1.488		.031	.118	6390	3200			
CL-162	1.625	1.568		.039	.029	1.550		.031	.118	6650	3330			
CL-168	1.687	1.630		.039	.029	1.612		.031	.118	6900	3460			
CL-175	1.750	1.693	+ .005	.039	.029	1.674	+ .000	.031	.118	7160	3590			
CL-181	1.812	1.755	- .005	.039	.029	1.736	- .020	.031	.118	7410	3710			
CL-187	1.875	1.818		.039	.029	1.798		.031	.118	7670	3840			
CL-193	1.937	1.880		.039	.029	1.859		.031	.118	7920	3970			
CL-200	2.000	1.943		.039	.029	1.922		.031	.118	8180	4100			
CL-206	2.062	1.986		.039	.038	1.963		.031	.158	8430	5540			
CL-212	2.125	2.049		.039	.038	2.026		.031	.158	8690	5710			
CL-218	2.187	2.111		.039	.038	2.087		.031	.158	8950	5870			
CL-225	2.250	2.174		.039	.038	2.149		.031	.158	9200	6040			
CL-231	2.312	2.236		.039	.038	2.211		.031	.158	9460	6210			
CL-237	2.375	2.299		.039	.038	2.273		.031	.158	9720	6380			
CL-243	2.437	2.361		.039	.038	2.335	+ .000	.031	.158	9970	6550			
CL-250	2.500	2.424		.039	.038	2.397	- .025	.031	.158	10230	6720			
CL-256	2.562	2.486	+ .006	.039	.038	2.458		.031	.158	10480	6880			
CL-262	2.625	2.549	- .006	.039	.038	2.521		.031	.158	10740	7050			
CL-268	2.687	2.611		.039	.038	2.582		.031	.158	10990	7220			
CL-275	2.750	2.674		.039	.038	2.644		.031	.158	11250	7390			
CL-281	2.812	2.736		.039	.038	2.706		.031	.158	11500	7550			
CL-287	2.875	2.799		.039	.038	2.768		.031	.158	11760	7720			
CL-293	2.937	2.861		.039	.038	2.830		.031	.158	12010	7890			
CL-300	3.000	2.924		.039	.038	2.892		.031	.158	12270	8060			
CL-306	3.062	2.970		.044	.046	2.938	+ .000	.039	.188	15760	9960			
CL-312	3.125	3.033		.044	.046	3.001	- .030	.039	.188	16080	10160			

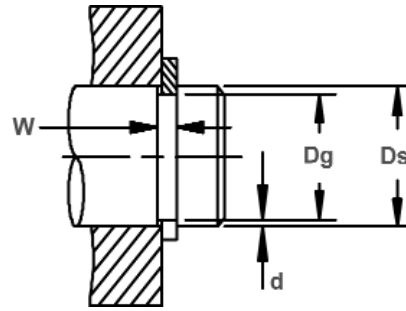
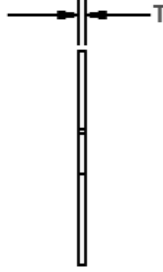
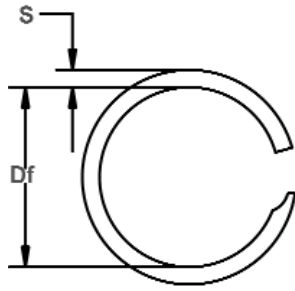

Free Diameter & Ring Measurements

Shaft Diameter & Groove Dimensions

RING NO.	SHAFT DIAMETER (In.)	GROOVE SIZE					RING SIZE					THRUST LOAD (lbs.)		
		DIAMETER		WIDTH		DEPTH	FREE DIAMETER		THICKNESS		SECTION		RING Safety factor of 3	GROOVE Safety factor of 2
		Ds	Dg Tol.	W Tol.	d	Df Tol.	T Tol.	S Tol.	Ring Safety factor of 3	Groove Safety factor of 2				
CL-318	3.187	3.095	.044	.046	3.062	.039	.188	16400	10360					
CL-325	3.250	3.158	.044	.046	3.125	.039	.188	16720	10570					
CL-331	3.312	3.220	.044	.046	3.186	.039	.188	17040	10770					
CL-337	3.375	3.283	.044	.046	3.248	.039	.188	17370	10970					
CL-343	3.437	3.345	.044	.046	3.310	.039	.188	17690	11180					
CL-350	3.500	3.408	.044	.046	3.372	.039	.188	18010	11380					
CL-356	3.562	3.47	.044	.046	3.433	.039	.188	18330	11580					
CL-362	3.625	3.533	.044	.046	3.496	.039	.188	18650	11790					
CL-368	3.687	3.595	.044	.046	3.557	.039	.188	18970	11990					
CL-375	3.750	3.658	.044	.046	3.620	.039	.188	19300	12190					
CL-381	3.812	3.720	.044	.046	3.681	.039	.188	19620	12400					
CL-387	3.875	3.783	.044	.046	3.743	.039	.188	19940	12600					
CL-393	3.937	3.845	.044	.046	3.805	.039	.188	20260	12800					
CL-400	4.000	3.908	.044	.046	3.867	.039	.188	20580	13010					
CL-412	4.125	4.015	.052	.055	3.973	.046	.225	23850	16040					
CL-425	4.250	4.140	.052	.055	4.097	.046	.225	24570	16520					
CL-437	4.375	4.265	.052	.055	4.221	.046	.225	25290	17010					
CL-450	4.500	4.390	.052	.055	4.345	.046	.225	26010	17500					
CL-462	4.625	4.515	.052	.055	4.468	.046	.225	26740	17980					
CL-475	4.750	4.640	.052	.055	4.592	.046	.225	27460	18470					
CL-487	4.875	4.765	.052	.055	4.715	.046	.225	28180	18950					
CL-500	5.000	4.890	.052	.055	4.839	.046	.225	28900	19440					
CL-525	5.250	5.119	.067	.066	5.067	.061	.225	40240	24490					
CL-550	5.500	5.363	.067	.069	5.309	.061	.225	42160	26830					
CL-575	5.750	5.606	.067	.072	5.550	.061	.225	44080	29260					
CL-600	6.000	5.850	.067	.075	5.792	.061	.225	45990	31810					
CL-625	6.250	6.094	.067	.078	6.033	.061	.265	47910	34460					
CL-650	6.500	6.338	.067	.081	6.275	.061	.265	49830	37220					
CL-675	6.750	6.581	.067	.085	6.515	.061	.265	51740	40560					
CL-700	7.000	6.825	.067	.088	6.757	.061	.265	53660	43540					
CL-725	7.250	7.069	.067	.091	6.998	.061	.300	55580	46640					
CL-750	7.500	7.313	.067	.094	7.240	.061	.300	57490	49830					
CL-775	7.750	7.556	.067	.097	7.480	.061	.300	59410	53140					
CL-800	8.000	7.800	.067	.100	7.722	.061	.300	61320	56550					
CL-825	8.250	8.044	.082	.103	7.964	.076	.345	78790	60070					
CL-850	8.500	8.288	.082	.106	8.205	.076	.345	81180	63690					
CL-875	8.750	8.531	.082	.110	8.446	.076	.345	83570	68040					
CL-900	9.000	8.775	.082	.113	8.687	.076	.345	85950	71890					
CL-925	9.250	9.019	.082	.116	8.929	.076	.345	88340	75850					
CL-950	9.500	9.263	.082	.119	9.170	.076	.345	90730	79910					
CL-975	9.750	9.506	.082	.122	9.411	.076	.345	93120	84080					
CL-1000	10.000	9.750	.082	.125	9.653	.076	.345	95500	88360					

KM Spiral Housing Rings

Internal, Medium Duty

These rings offer the greatest economy in price and size. They are able to handle approximately twice the thrust capacity of the KL series, and to be produced to military specifications if needed.

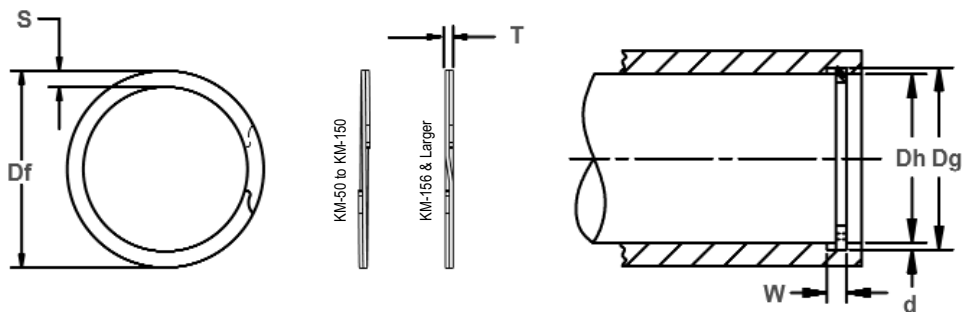

Free Diameter & Ring Measurements

Housing Diameter & Groove Dimensions

RING NO.	HOUSING DIAMETER (In.)	GROOVE SIZE					RING SIZE				THRUST LOAD (lbs.)			
		DIAMETER		WIDTH		DEPTH	FREE DIAMETER		THICKNESS		SECTION		RING Safety factor of 3	GROOVE Safety factor of 2
		Dg	Tol.	W	Tol.	d	Df	Tol.	T	Tol.	S	Tol.		
KM-50	.500	.526	+.002 -.002	.030	+.003 -.000	.013	.532	+.013 -.000	.025	+.002 -.002	.045	±.004	2000	460
KM-51	.512	.538		.030		.013	.544		.025		.045		2050	470
KM-53	.531	.557		.030		.013	.564		.025		.045		2130	490
KM-56	.562	.588		.030		.013	.594		.025		.045		2250	520
KM-59	.594	.619		.030		.013	.626		.025		.045		2380	550
KM-62	.625	.651		.030		.013	.658		.025		.045		2500	570
KM-65	.656	.682		.030		.013	.689		.025		.045		2630	600
KM-68	.687	.713		.030		.013	.720		.025		.045		2750	630
KM-71	.718	.744		.030		.013	.751		.025		.045		2870	660
KM-75	.750	.782		.036		.016	.790		.031		.065		3360	850
KM-77	.777	.808	+.003 -.003	.036	+.004 -.004	.016	.817	+.015 -.000	.031	+.002 -.002	.065	±.004	3480	880
KM-78	.781	.812		.036		.016	.821		.031		.065		3500	880
KM-81	.812	.843		.036		.016	.853		.031		.065		3640	920
KM-84	.843	.880		.036		.019	.889		.031		.065		3780	1130
KM-86	.866	.903		.036		.019	.913		.031		.065		3880	1160
KM-87	.875	.912		.036		.019	.922		.031		.065		3920	1180
KM-90	.906	.943		.036		.019	.953		.031		.065		4060	1220
KM-93	.938	.975		.042		.021	.986		.037		.075		4200	1260
KM-96	.968	1.011		.042		.021	1.022		.037		.075		5180	1440
KM-98	.987	1.030		.042		.021	1.041		.037		.075		5280	1470
KM-100	1.000	1.043	.042	.021	1.054	.037	.075	5350	1480					
KM-102	1.023	1.066	.042	.021	1.078	.037	.075	5470	1520					
KM-103	1.031	1.074	+.004 -.004	.042	+.004 -.000	.021	1.084	+.015 -.000	.037	+.002 -.002	.075	±.004	5510	1530
KM-106	1.062	1.104		.042		.021	1.117		.037		.075		5680	1580
KM-109	1.093	1.135		.042		.021	1.147		.037		.075		5840	1620
KM-112	1.125	1.167		.042		.021	1.180		.037		.075		6020	1670
KM-115	1.156	1.198		.042		.021	1.210		.037		.075		6180	1720
KM-118	1.188	1.236		.048		.024	1.249		.043		.085		7380	2020
KM-121	1.218	1.266		.048		.024	1.278		.043		.085		7570	2070
KM-125	1.250	1.298		.048		.024	1.312		.043		.085		7770	2120
KM-128	1.281	1.329		.048		.024	1.342		.043		.085		7960	2170
KM-131	1.312	1.360		.048		.024	1.374		.043		.085		8150	2230
KM-134	1.343	1.395	.048	.026	1.408	.043	.085	8350	2470					
KM-137	1.375	1.427	.048	.026	1.442	.043	.095	8540	2530					
KM-140	1.406	1.458	.048	.026	1.472	.043	.095	8740	2580					
KM-143	1.437	1.489	.048	.026	1.504	.043	.095	8930	2640					
KM-145	1.456	1.508	.048	.026	1.523	.043	.095	9050	2680					
KM-146	1.468	1.520	.048	.026	1.535	.043	.095	9120	2700					
KM-150	1.500	1.552	.048	.026	1.567	.043	.095	9320	2760					

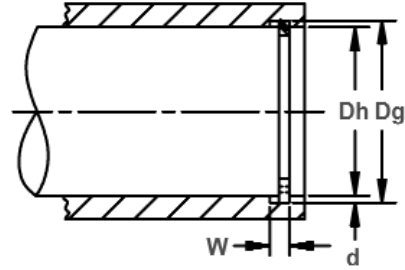
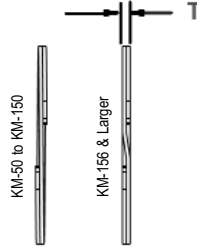
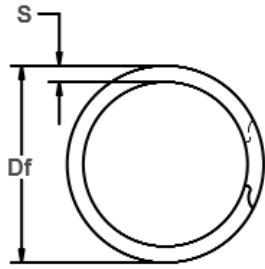

Free Diameter & Ring Measurements

Housing Diameter & Groove Dimensions

RING NO.	HOUSING DIAMETER		GROOVE SIZE				RING SIZE				THRUST LOAD (lbs.)			
	(In.)	DIAMETER		WIDTH		DEPTH	FREE DIAMETER		THICKNESS		SECTION		RING Safety factor of 3	GROOVE Safety factor of 2
		Dh	Dg	Tol.	W		Tol.	d	Df	Tol.	T	Tol.		
KM-156	1.562	1.617		.056		.028	1.634		.049		.108		10100	3090
KM-157	1.574	1.633		.056		.030	1.649		.049		.108		10180	3340
KM-162	1.625	1.684		.056		.030	1.701		.049		.108		10510	3350
KM-165	1.653	1.712		.056		.030	1.730		.049		.108		10690	3510
KM-168	1.687	1.750	+.005 -.005	.056		.031	1.768	+.020 -.000	.049		.118		10910	3700
KM-175	1.750	1.813		.056		.031	1.834		.049		.118			
KM-181	1.813	1.875		.056		.031	1.894		.049		.118			
KM-185	1.850	1.917		.056		.034	1.937		.049		.118		11960	4450
KM-187	1.875	1.942		.056		.034	1.960		.049		.118		12120	4510
KM-193	1.938	2.005		.056		.034	2.025		.049		.118		12530	4660
KM-200	2.000	2.071		.056		.035	2.091		.049		.128		12930	4950
KM-204	2.047	2.118		.056		.035	2.138		.049		.128		18240	5060
KM-206	2.062	2.132	+.006 -.006	.056		.035	2.154	+.025 -.000	.049	+.003 -.003	.128	±.004	13330	5100
KM-212	2.125	2.195		.056		.035	2.217		.049		.128			
KM-216	2.165	2.239		.056		.037	2.260		.049		.138			
KM-218	2.188	2.262		.056		.037	2.284		.049		.138			
KM-225	2.250	2.324		.056		.037	2.347		.049		.138			
KM-231	2.312	2.390		.056		.039	2.413		.049		.138			
KM-237	2.375	2.453		.056		.039	2.476		.049		.138			
KM-243	2.437	2.519		.056		.041	2.543		.049		.148			
KM-244	2.440	2.522		.056		.041	2.546		.049		.148			
KM-250	2.500	2.582		.056		.041	2.606		.049		.148			
KM-253	2.531	2.617	.056	.043	2.641	.049	.148							
KM-256	2.562	2.648		.056		.043	2.673		.049		.148		16560	7790
KM-262	2.625	2.711		.056		.043	2.736		.049		.148		16970	7980
KM-267	2.677	2.767		.056		.045	2.789		.049		.158		17310	8520
KM-268	2.688	2.778		.056		.045	2.803		.049		.158		17380	8550
KM-275	2.750	2.841		.056		.045	2.865		.049		.158		17780	8750
KM-281	2.813	2.903		.056		.045	2.929		.049		.158		18190	8950
KM-283	2.834	2.928		.056		.047	2.954		.049		.168		18320	9520
KM-287	2.875	2.969		.056		.047	2.995		.049		.168		18590	9550
KM-293	2.937	3.031		.056		.047	3.058		.049		.168		18990	9760
KM-295	2.952	3.046		.056		.047	3.073		.049		.168		19090	9810
KM-300	3.000	3.096		.068		.048	3.122		.061		.168		24150	10180
KM-306	3.062	3.158		.068		.048	3.186		.061		.168	±.005	24650	10390
KM-312	3.125	3.223		.068		.048	3.251		.061		.178		25150	10600
KM-314	3.149	3.247	+.005 -.000	.068		.048	3.276	+.030 -.000	.061		.178		25350	10680
KM-318	3.187	3.283		.068		.048	3.311		.061		.178			
KM-325	3.250	3.350		.068		.050	3.379		.061		.178			
KM-331	3.312	3.416		.068		.052	3.446		.061		.188			
KM-334	3.346	3.450		.068		.052	3.479		.061		.188			
KM-337	3.375	3.479		.068		.052	3.509		.061		.188			

KM Spiral Housing Rings

Internal, Medium Duty
 These rings offer the greatest economy in price and size. They are able to handle approximately twice the thrust capacity of the KL series, and to be produced to military specifications if needed.

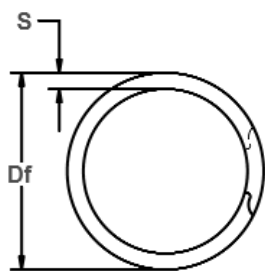

Free Diameter & Ring Measurements

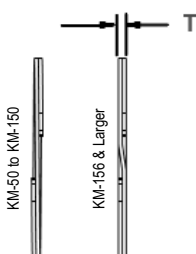

Housing Diameter & Groove Dimensions

RING NO.	HOUSING DIAMETER (In.) Dh	GROOVE SIZE					RING SIZE						THRUST LOAD (lbs.)		
		DIAMETER		WIDTH		DEPTH	FREE DIAMETER			THICKNESS		SECTION		RING Safety factor of 3	GROOVE Safety factor of 2
		Dg	Tol.	W	Tol.	d	Df	Tol.	T	Tol.	S	Tol.			
KM-343	3.437	3.543		.068		.053	3.574		.061		.188		27660	12880	
KM-350	3.500	3.606		.068		.053	3.636		.061		.188		28170	13110	
KM-354	3.543	3.653		.068		.055	3.684		.061		.198		28520	13770	
KM-356	3.562	3.672		.068		.055	3.703		.061		.198		28670	13850	
KM-362	3.625	3.737		.068		.056	3.769		.061		.198		29180	14350	
KM-368	3.687	3.799		.068		.056	3.832	+.030	.061		.198		29680	14600	
KM-374	3.740	3.852		.068		.056	3.885	-.000	.061		.198		30100	14800	
KM-375	3.750	3.862		.068		.056	3.894		.061	+.003	.198		30180	14840	
KM-381	3.812	3.930		.068		.059	3.963		.061	-.003	.208		30680	15900	
KM-387	3.875	3.993		.068		.059	4.025		.061		.208		31190	16160	
KM-393	3.938	4.056		.068		.059	4.089		.061		.208		31700	16420	
KM-400	4.000	4.124		.068		.062	4.157		.061		.218		32200	17530	
KM-406	4.063	4.187		.068		.062	4.222		.061		.218		32700	17810	
KM-412	4.125	4.249	+.006	.068		.062	4.284		.061		.218		33200	18080	
KM-418	4.188	4.311	-.006	.068	+.005	.062	4.347		.061		.218		33710	18350	
KM-425	4.250	4.380		.068	-.000	.065	4.416		.061		.228		34210	19530	
KM-431	4.312	4.442		.068		.065	4.479		.061		.228		34710	19810	
KM-433	4.330	4.460		.068		.065	4.497		.061		.228		34850	19900	
KM-437	4.375	4.505		.068		.065	4.543		.061		.228	±.005	35210	20100	
KM-443	4.437	4.573		.068		.068	4.611		.061		.238		35710	21330	
KM-450	4.500	4.636		.068		.068	4.674		.061		.238		36220	21630	
KM-452	4.527	4.663		.068		.068	4.701		.061		.238		36440	21760	
KM-456	4.562	4.698		.068		.068	4.737	+.035	.061		.238		36720	21930	
KM-462	4.625	4.765		.079		.070	4.803	-.000	.072		.250		43940	22890	
KM-468	4.687	4.827		.079		.070	4.867		.072		.250		44530	23190	
KM-472	4.724	4.864		.079		.070	4.903		.072		.250		44880	23370	
KM-475	4.750	4.890		.079		.070	4.930		.072		.250		45130	23500	
KM-481	4.812	4.952		.079		.070	4.993		.072		.250		45720	23810	
KM-487	4.875	5.015		.079		.070	5.055		.072		.250		46310	24120	
KM-492	4.921	5.061		.079		.070	5.102		.072		.250		46750	24350	
KM-493	4.937	5.081		.079		.072	5.122		.072	+.004	.250		46900	25130	
KM-500	5.000	5.144		.079		.072	5.185		.072	-.004	.250		47500	25450	
KM-511	5.118	5.262		.079		.072	5.304		.072		.250		48620	26050	
KM-512	5.125	5.269		.079		.072	5.311		.072		.250		48690	26100	
KM-525	5.250	5.393		.079		.072	5.436		.072		.250		49880	26720	
KM-537	5.375	5.522		.079		.074	5.566		.072		.250		51060	28120	
KM-550	5.500	5.647	+.007	.079		.074	5.693	+.045	.072		.250		52250	28770	
KM-551	5.511	5.658	-.007	.079		.074	5.703	-.000	.072		.250		52360	28830	
KM-562	5.625	5.772		.079		.074	5.818		.072		.250		53440	29400	
KM-570	5.708	5.861		.079		.077	5.909		.072		.250		54230	31070	
KM-575	5.750	5.903		.079		.077	5.950		.072		.250		54630	31300	

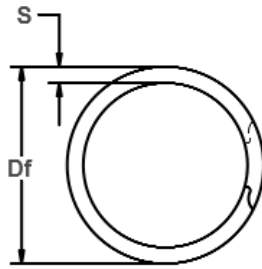

KM-50 to KM-150

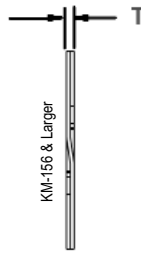

KM-156 & Larger

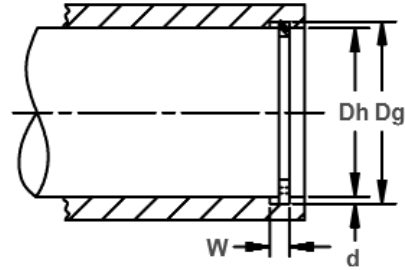

Free Diameter & Ring Measurements

Housing Diameter & Groove Dimensions

RING NO.	HOUSING DIAMETER (In.)	GROOVE SIZE					RING SIZE					THRUST LOAD (lbs.)		
		DIAMETER		WIDTH		DEPTH	FREE DIAMETER		THICKNESS		SECTION		RING Safety factor of 3	GROOVE Safety factor of 2
		Dg	Tol.	W	Tol.	d	Df	Tol.	T	Tol.	S	Tol.		
KM-587	5.875	6.028	+ .007	.079	+ .005	.077	6.077		.072		.250		55810	31980
KM-590	5.905	6.058	- .007	.079	- .005	.077	6.106	+ .045	.072		.250	± .005	56100	32140
KM-600	6.000	6.153		.079		.077	6.202	- .000	.072		.250		57000	32660
KM-612	6.125	6.297		.094		.086	6.349		.086		.312		69500	37200
KM-625	6.250	6.422		.094		.086	6.474		.086		.312		70920	37990
KM-629	6.299	6.471		.094		.086	6.524		.086		.312		71480	38290
KM-637	6.375	6.547		.094		.086	6.601		.086		.312		72340	38750
KM-650	6.500	6.672		.094		.086	6.726		.086		.312		73760	39510
KM-662	6.625	6.807		.094		.091	6.863	+ .055	.086		.312		75180	42620
KM-669	6.692	6.874		.094		.091	6.931	- .000	.086		.312		75940	43050
KM-675	6.750	6.932		.094		.091	6.987		.086		.312		76600	43420
KM-687	6.875	7.057		.094		.091	7.114		.086		.312		78010	44220
KM-700	7.000	7.182		.094		.091	7.239		.086		.312		79430	45030
KM-708	7.086	7.278		.094		.096	7.337		.086		.312		80410	48080
KM-712	7.125	7.317		.094		.096	7.376		.086		.312		80850	48350
KM-725	7.250	7.442		.094		.096	7.501		.086		.312		82270	49200
KM-737	7.375	7.567		.094		.096	7.628		.086		.312		83690	50050
KM-748	7.480	7.672		.094		.096	7.734		.086		.312		84880	50760
KM-750	7.500	7.692	+ .008	.094	+ .006	.096	7.754		.086		.312	± .006	85110	50890
KM-762	7.625	7.827	- .008	.094	- .006	.101	7.890		.086		.312		86520	54440
KM-775	7.750	7.952		.094		.101	8.014		.086	+ .004	.312	- .004	87940	55330
KM-787	7.875	8.077		.094		.101	8.141		.086		.312		89360	63360
KM-800	8.000	8.202		.094		.101	8.266		.086		.312		90780	57110
KM-825	8.250	8.462		.094		.106	8.528		.086		.375		93620	61820
KM-826	8.267	8.479		.094		.106	8.546		.086		.375		93810	61940
KM-846	8.464	8.676		.094		.106	8.744	+ .065	.086		.375		96050	63420
KM-850	8.500	8.712		.094		.106	8.780	- .000	.086		.375		96450	63690
KM-875	8.750	8.972		.094		.111	9.041		.086		.375		99290	68650
KM-885	8.858	9.080		.094		.111	9.151		.086		.375		100520	69500
KM-900	9.000	9.222		.094		.111	9.293		.086		.375		102130	70620
KM-905	9.055	9.287		.094		.116	9.359		.086		.375		102750	74250
KM-925	9.250	9.482		.094		.116	9.555		.086		.375		104960	75850
KM-944	9.448	9.680		.094		.116	9.755		.086		.375		107210	77470
KM-950	9.500	9.732		.094		.116	9.806		.086		.375		107800	77900
KM-975	9.750	9.992		.094		.121	10.068		.086		.375		110640	83390
KM-1000	10.000	10.242		.094		.121	10.320		.086		.375		113470	85530
KM-1025	10.250	10.502		.094		.126	10.582		.086		.375		116310	91290
KM-1050	10.500	10.752		.094		.126	10.834		.086		.375		119150	93520
KM-1075	10.750	11.012		.094		.131	11.095		.086		.375		121990	99540
KM-1100	11.000	11.262		.094		.131	11.347		.086		.375		124820	101860

CM Spiral Shaft Rings

External, Medium Duty

These rings offer the greatest economy in price and size. They are able to handle approximately twice the thrust capacity of the CL series, and to be produced to military specifications if needed.

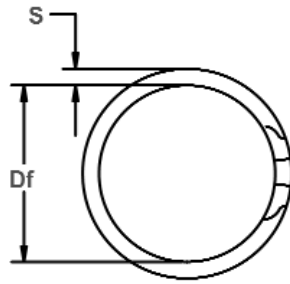

Free Diameter & Ring Measurements

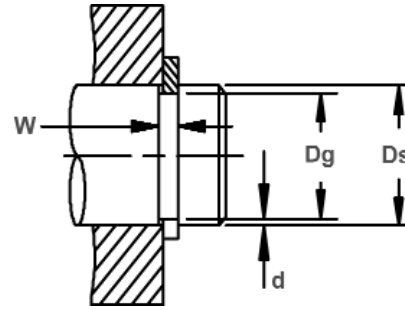
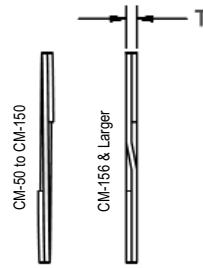

Shaft Diameter & Groove Dimensions

RING NO.	SHAFT DIAMETER (In.)	GROOVE SIZE					RING SIZE						THRUST LOAD (lbs.)		
		DIAMETER		WIDTH		DEPTH	FREE DIAMETER			THICKNESS		SECTION		RING Safety factor of 3	GROOVE Safety factor of 2
		Ds	Dg	Tol.	W	Tol.	d	Df	Tol.	T	Tol.	S	Tol.		
CM-50	.500	.474		.030		.013	.467		.025		.045		2000	460	
CM-53	.531	.505	+ .002	.030		.013	.498		.025		.045		2130	490	
CM-55	.551	.525	- .002	.030		.013	.518		.025		.045		2210	510	
CM-56	.562	.536		.030		.013	.529		.025		.045		2250	520	
CM-59	.594	.569		.030		.013	.561		.025		.045		2380	550	
CM-62	.625	.594		.030		.016	.585		.025		.055		2500	710	
CM-65	.656	.625		.030		.016	.617		.025		.055		2630	740	
CM-66	.669	.638		.030		.016	.629		.025		.055		2680	760	
CM-68	.687	.656		.030		.016	.647		.025		.055		2750	780	
CM-71	.718	.687		.030		.016	.679	+ .000	.025		.055		2880	810	
CM-75	.750	.719		.036		.016	.710	- .013	.031		.065		3360	850	
CM-78	.781	.750	+ .003	.036	+ .003	.016	.741		.031		.065		3500	880	
CM-81	.812	.781	- .003	.036	- .000	.016	.771		.031		.065		3640	920	
CM-84	.843	.812		.036		.016	.803		.031		.065		3780	950	
CM-87	.875	.838		.036		.019	.828		.031		.065		3920	1180	
CM-90	.906	.869		.036		.019	.860		.031		.065		4060	1220	
CM-93	.937	.900		.036		.019	.889		.031	+ .002	.065	+ .004	4200	1260	
CM-96	.968	.925		.042		.021	.916		.037	- .002	.075	- .004	5180	1440	
CM-98	.984	.941		.042		.021	.930		.037		.075		5260	1460	
CM-100	1.000	.957		.042		.021	.946		.037		.075		5350	1480	
CM-102	1.023	.980		.042		.021	.968		.037		.075		5470	1520	
CM-103	1.031	.988		.042		.021	.978		.037		.075		5510	1530	
CM-106	1.062	1.020		.042		.021	1.007		.037		.075		5680	1580	
CM-109	1.093	1.051		.042		.021	1.040		.037		.075		5840	1620	
CM-112	1.125	1.083		.042		.021	1.070		.037		.075		6020	1670	
CM-115	1.156	1.114		.042		.021	1.102		.037		.075		6180	1720	
CM-118	1.188	1.140		.048		.024	1.127		.043		.085		7380	2020	
CM-121	1.218	1.170		.048		.024	1.159		.043		.085		7570	2070	
CM-125	1.250	1.202	+ .004	.048		.024	1.188	+ .000	.043		.085		7770	2120	
CM-128	1.281	1.233	- .004	.048		.024	1.221	- .015	.043		.085		7960	2170	
CM-131	1.312	1.264		.048	+ .004	.024	1.251		.043		.095		8150	2230	
CM-134	1.343	1.295		.048	- .000	.024	1.282		.043		.095		8350	2280	
CM-137	1.375	1.323		.048		.026	1.308		.043		.095		8540	2530	
CM-140	1.406	1.354		.048		.026	1.340		.043		.095		8740	2580	
CM-143	1.437	1.385		.048		.026	1.370		.043		.095		8930	2640	
CM-146	1.468	1.416		.048		.026	1.402		.043		.095		9120	2700	
CM-150	1.500	1.448		.048		.026	1.433		.043		.095		9320	2760	

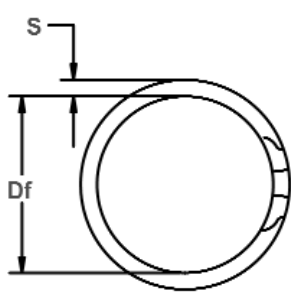

Free Diameter & Ring Measurements

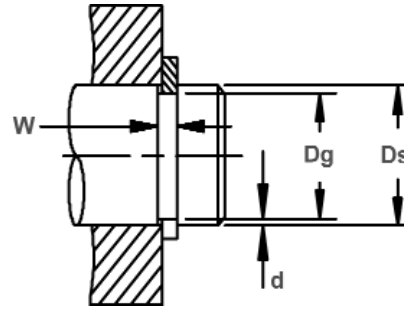
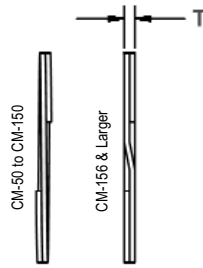

Shaft Diameter & Groove Dimensions

RING NO.	SHAFT DIAMETER (In.)	GROOVE SIZE					RING SIZE						THRUST LOAD (lbs.)		
		DIAMETER		WIDTH		DEPTH	FREE DIAMETER			THICKNESS		SECTION		RING Safety factor of 3	GROOVE Safety factor of 2
		Ds	Dg	Tol.	W	Tol.	d	Df	Tol.	T	Tol.	S	Tol.		
CM-156	1.562	1.507		.056		.028	1.490		.049		.108		10100	3090	
CM-157	1.575	1.520		.056		.028	1.503		.049		.108		10190	3120	
CM-162	1.625	1.566		.056		.030	1.549		.049		.108		10510	3450	
CM-168	1.687	1.628		.056		.030	1.610		.049		.118		10910	3580	
CM-175	1.750	1.691	+ .005	.056		.030	1.673		.049		.118		11310	3710	
CM-177	1.771	1.708	- .005	.056		.032	1.690		.049		.118		11450	4010	
CM-181	1.813	1.749		.056		.032	1.730	+ .000	.049		.118		11720	4100	
CM-187	1.875	1.808		.056		.034	1.789	- .020	.049		.128		12120	4510	
CM-193	1.938	1.871		.056		.034	1.851		.049		.128		12530	4660	
CM-196	1.969	1.902		.056		.034	1.882		.049		.128	+ .004	12730	4730	
CM-200	2.000	1.929		.056		.035	1.909		.049		.128	- .004	12930	4950	
CM-206	2.062	1.992		.056		.035	1.971		.049		.128		13330	5100	
CM-212	2.125	2.051		.056	+ .004	.037	2.029		.049		.128		13740	5560	
CM-215	2.156	2.082		.056	- .000	.037	2.060		.049		.138		13940	5640	
CM-216	2.165	2.091		.056		.037	2.070		.049	+ .003	.138		14000	5660	
CM-218	2.188	2.113		.056		.037	2.092		.049	- .003	.138		14150	5720	
CM-225	2.250	2.176		.056		.037	2.153		.049		.138		14550	5890	
CM-231	2.312	2.234		.056		.039	2.211		.049		.138		14950	6370	
CM-236	2.362	2.284		.056		.039	2.261	+ .000	.049		.138		15270	6510	
CM-237	2.375	2.297		.056		.039	2.273	- .025	.049		.138		15360	6550	
CM-243	2.437	2.355		.056		.041	2.331		.049		.148		15760	7060	
CM-250	2.500	2.418	+ .006	.056		.041	2.394		.049		.148		16160	7250	
CM-255	2.559	2.473	- .006	.056		.043	2.449		.049		.148		16550	7780	
CM-256	2.562	2.476		.056		.043	2.452		.049		.148		16560	7790	
CM-262	2.625	2.539		.056		.043	2.514		.049		.148		16970	7980	
CM-268	2.688	2.597		.056		.045	2.572		.049		.158		17380	8550	
CM-275	2.750	2.660		.056		.045	2.635		.049		.158		17780	8750	
CM-281	2.813	2.722		.056		.045	2.696		.049		.168		18190	8950	
CM-287	2.875	2.781		.056		.047	2.755		.049		.168		18590	9550	
CM-293	2.937	2.843		.056		.047	2.817		.049		.168		18990	9760	
CM-295	2.952	2.858		.056		.047	2.831	+ .000	.049		.168		19090	9810	
CM-300	3.000	2.904		.068		.048	2.877	- .030	.061		.168	+ .005	24150	10180	
CM-306	3.062	2.966		.068		.048	2.938		.061		.168	- .005	24650	10390	
CM-312	3.125	3.027		.068		.049	3.000		.061		.178		25150	10820	
CM-314	3.149	3.051		.068	+ .005	.049	3.023		.061		.178		25350	10910	
CM-318	3.187	3.089		.068	- .000	.049	3.061		.061		.178		25650	11040	
CM-325	3.250	3.150		.068		.050	3.121		.061		.178		26160	11490	

CM Spiral Shaft Rings

External, Medium Duty

These rings offer the greatest economy in price and size.

They are able to handle approximately twice the thrust capacity of the CL series, and to be produced to military specifications if needed.

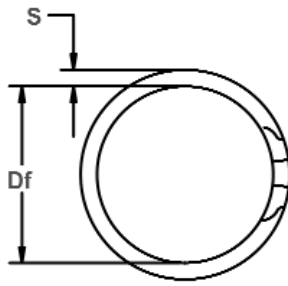

Free Diameter & Ring Measurements

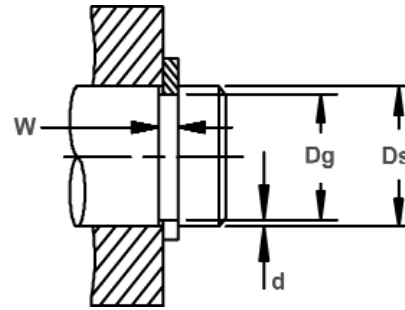
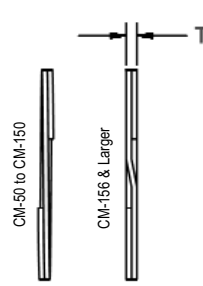

Shaft Diameter & Groove Dimensions

RING NO.	SHAFT DIAMETER (In.)		GROOVE SIZE				RING SIZE				THRUST LOAD (lbs.)			
			DIAMETER		WIDTH		DEPTH	FREE DIAMETER		THICKNESS		SECTION	RING Safety factor of 3	GROOVE Safety factor of 2
			Ds	Dg	Tol.	W	Tol.	d	Df	Tol.	T			
CM-331	3.312	3.208		.068		.052	3.180		.061		.188		26660	12170
CM-334	3.343	3.239		.068		.052	3.210	+ .000	.061		.188		26910	12290
CM-337	3.375	3.271		.068		.052	3.242	- .030	.061		.188		27170	12410
CM-343	3.437	3.331		.068		.053	3.301		.061		.188		27660	12880
CM-350	3.500	3.394		.068		.053	3.363		.061		.188		28170	13110
CM-354	3.543	3.433		.068		.055	3.402		.061		.198		28520	13770
CM-356	3.562	3.452		.068		.055	3.422		.061		.198		28670	13850
CM-362	3.625	3.515		.068		.055	3.483		.061		.198		29180	14090
CM-368	3.687	3.575		.068		.056	3.543		.061		.198		29680	14600
CM-374	3.740	3.628		.068		.056	3.597		.061		.198		30100	14800
CM-375	3.750	3.638		.068		.056	3.606		.061		.198		30180	14840
CM-381	3.812	3.700		.068		.056	3.668		.061	+ .003	.198		30680	15090
CM-387	3.875	3.757		.068		.059	3.724		.061	- .003	.208		31190	16160
CM-393	3.938	3.820		.068		.059	3.784		.061		.208	+ .005	31700	16420
CM-400	4.000	3.876	+ .006	.068	+ .005	.062	3.842		.061		.218	- .005	32200	17530
CM-406	4.063	3.939	- .006	.068	- .000	.062	3.906		.061		.218		32700	17810
CM-412	4.125	4.000		.068		.062	3.967		.061		.218		33200	18080
CM-413	4.134	4.010		.068		.062	3.975		.061		.218		33270	18120
CM-418	4.188	4.058		.068		.065	4.022	+ .000	.061		.218		33710	19240
CM-425	4.250	4.120		.068		.065	4.084	- .040	.061		.228		34210	19530
CM-431	4.312	4.182		.068		.065	4.147		.061		.228		34710	19810
CM-433	4.331	4.200		.068		.065	4.164		.061		.228		34860	19900
CM-437	4.375	4.245		.068		.065	4.208		.061		.228		35210	20100
CM-443	4.437	4.307		.068		.065	4.271		.061		.228		35710	20390
CM-450	4.500	4.364		.068		.068	4.326		.061		.238		36220	21630
CM-456	4.562	4.422		.079		.070	4.384		.072		.250		43340	22570
CM-462	4.625	4.485		.079		.070	4.447		.072		.250		43940	22890
CM-468	4.687	4.547		.079		.070	4.508		.072		.250		44530	23190
CM-472	4.724	4.584		.079		.070	4.546		.072		.250		44880	23370
CM-475	4.750	4.610		.079		.070	4.571		.072	+ .004	.250		45130	23500
CM-481	4.812	4.672		.079		.070	4.633		.072	- .004	.250		45720	23810
CM-487	4.875	4.735		.079		.070	4.695		.072		.250		46310	24120
CM-493	4.937	4.797		.079		.070	4.757		.072		.250		46900	24430
CM-500	5.000	4.856		.079		.072	4.816		.072		.250		47500	25450
CM-511	5.118	4.974		.079		.072	4.934		.072		.250		48620	26050
CM-512	5.125	4.981		.079		.072	4.939		.072		.250		48690	26080

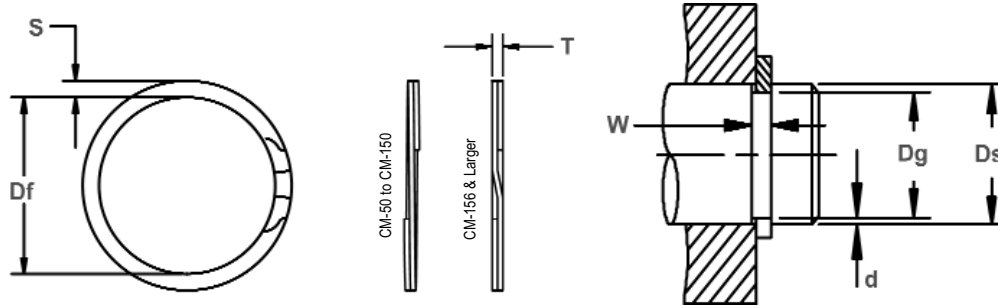

Free Diameter & Ring Measurements

Shaft Diameter & Groove Dimensions

RING NO.	SHAFT DIAMETER (In.)	GROOVE SIZE					RING SIZE				THRUST LOAD (lbs.)			
		DIAMETER		WIDTH		DEPTH	FREE DIAMETER		THICKNESS		SECTION		RING Safety factor of 3	GROOVE Safety factor of 2
		Ds	Dg	Tol.	W	Tol.	d	Df	Tol.	T	Tol.	S	Tol.	
CM-525	5.250	5.107		.079		.072	5.064		.072		.250		49880	26720
CM-537	5.375	5.228		.079		.074	5.187		.072		.250		51060	28120
CM-550	5.500	5.353		.079		.074	5.308		.072		.250		52250	28770
CM-551	5.511	5.364	+ .007	.079	+ .005	.074	5.320		.072		.250	+ .005	52360	28830
CM-562	5.625	5.478	- .007	.079	- .005	.074	5.433	+ .000	.072		.250	- .005	53440	29420
CM-575	5.750	5.597		.079		.077	5.550	- .050	.072		.250		54630	31300
CM-587	5.875	5.722		.079		.077	5.674		.072		.250		55810	31980
CM-590	5.905	5.752		.079		.077	5.705		.072		.250		56100	32140
CM-600	6.000	5.847		.079		.077	5.798		.072		.250		57000	32660
CM-612	6.125	5.953		.094		.086	5.903		.086		.312		69500	37230
CM-625	6.250	6.078		.094		.086	6.026		.086		.312		70920	37990
CM-629	6.299	6.127		.094		.086	6.076		.086		.312		71480	38290
CM-637	6.375	6.203		.094		.086	6.152		.086		.312		72340	38750
CM-650	6.500	6.328		.094		.086	6.274		.086		.312		73760	39510
CM-662	6.625	6.443		.094		.091	6.390	+ .000	.086		.312		75180	42620
CM-675	6.750	6.568		.094		.091	6.513	- .060	.086		.312		76600	43420
CM-687	6.875	6.693		.094		.091	6.638		.086		.312		78010	44220
CM-700	7.000	6.818		.094		.091	6.761		.086		.312		79430	45030
CM-712	7.125	6.933		.094		.096	6.877		.086	+ .004	.312		80850	48350
CM-725	7.250	7.058		.094		.096	6.999		.086	- .004	.312		82270	49200
CM-737	7.375	7.183		.094		.096	7.125		.086		.312		83690	50050
CM-750	7.500	7.308	+ .008	.094	+ .006	.096	7.250		.086		.312	+ .006	85110	50890
CM-762	7.625	7.423	- .008	.094	- .006	.101	7.363		.086		.312	- .006	86520	54440
CM-775	7.750	7.548		.094		.101	7.486		.086		.312		87940	55330
CM-787	7.875	7.673		.094		.101	7.611		.086		.312		89360	56220
CM-800	8.000	7.798		.094		.101	7.734		.086		.312		90780	57110
CM-825	8.250	8.038		.094		.106	7.972		.086		.375		93620	61820
CM-850	8.500	8.288		.094		.106	8.220	+ .000	.086		.375		96450	63690
CM-875	8.750	8.528		.094		.111	8.459	- .070	.086		.375		99290	68650
CM-900	9.000	8.778		.094		.111	8.707		.086		.375		102130	70620
CM-925	9.250	9.018		.094		.116	8.945		.086		.375		104960	75850
CM-950	9.500	9.268		.094		.116	9.194		.086		.375		107800	77900
CM-975	9.750	9.508		.094		.121	9.432		.086		.375		110640	83390
CM-1000	10.000	9.758		.094		.121	9.680		.086		.375		113470	85530
CM-1025	10.250	9.998		.094		.126	9.918		.086		.375		116310	91290
CM-1050	10.500	10.248		.094		.126	10.166		.086		.375		119150	93520
CM-1075	10.750	10.488		.094		.131	10.405		.086		.375		121990	99540
CM-1100	11.000	10.738		.094		.131	10.653		.086		.375		124820	101860



KG Spiral Housing Rings

Internal, Heavy Duty

The greatest size range and thrust capacity make these rings the only choice for applications that require minimum deflection or thrust loads that demand a deep groove capacity.

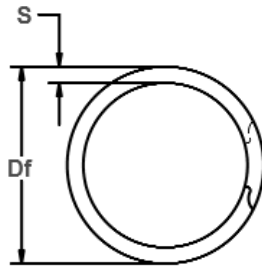

Free Diameter & Ring Measurements

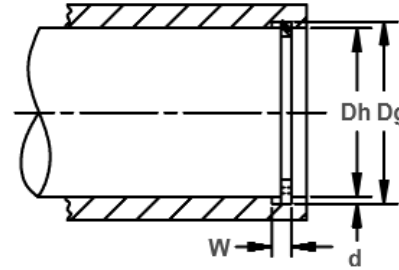
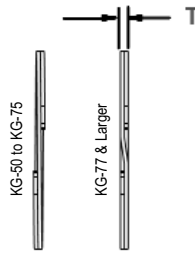

Housing Diameter & Groove Dimensions

RING NO.	HOUSING DIAMETER (In.)	GROOVE SIZE					RING SIZE				THRUST LOAD (lbs.)			
		DIAMETER		WIDTH		DEPTH	FREE DIAMETER		THICKNESS		SECTION		RING Safety factor of 3	GROOVE Safety factor of 2
		Dg	Tol.	W	Tol.	d	Df	Tol.	T	Tol.	S	Tol.		
KG-50	.500	.530		.039		.015	.538		.035		.045		2530	530
KG-51	.512	.542		.039		.015	.550		.035		.045		2590	540
KG-56	.562	.596	+.002	.039		.017	.605		.035		.055		2840	680
KG-62	.625	.665	-.002	.039		.020	.675		.035		.055		3160	880
KG-68	.688	.732		.039		.022	.743		.035		.065		3480	1070
KG-75	.750	.796		.039	+.003	.023	.807		.035		.065		3790	1220
KG-77	.777	.825		.046	-.000	.024	.836		.042		.075		4720	1320
KG-81	.812	.862		.046		.025	.873		.042		.075		4930	1440
KG-86	.866	.920		.046		.027	.931		.042		.075		5260	1650
KG-87	.875	.931	+.003	.046		.028	.943		.042		.085		5310	1730
KG-90	.901	.959	-.003	.046		.029	.972	+.013	.042	+.002	.085		5470	1850
KG-93	.938	1.000		.046		.031	1.013	-.000	.042	-.002	.085	+.004	5690	2060
KG-100	1.000	1.066		.046		.033	1.080		.042		.085	-.004	6070	2330
KG-102	1.023	1.091		.046		.034	1.105		.042		.085		6210	2460
KG-106	1.062	1.130		.056		.034	1.138		.050		.103		7010	2550
KG-112	1.125	1.197		.056		.036	1.205		.050		.103		7420	2860
KG-118	1.188	1.262		.056		.037	1.271		.050		.103		7840	3110
KG-125	1.250	1.330	+.004	.056		.040	1.339		.050		.103		8250	3530
KG-131	1.312	1.396	-.004	.056		.042	1.406		.050		.118		8660	3900
KG-137	1.375	1.461		.056	+.004	.043	1.471		.050		.118		9070	4180
KG-143	1.439	1.528		.056	-.000	.045	1.539		.050		.118		9490	4580
KG-145	1.456	1.548		.056		.046	1.559		.050		.118		9610	4730
KG-150	1.500	1.594		.056		.047	1.605		.050		.118		9900	4980
KG-156	1.562	1.658		.068		.048	1.675		.062		.128		12780	5300
KG-162	1.625	1.725	+.005	.068		.050	1.742	+.020	.062	+.003	.128		13290	5740
KG-165	1.653	1.755	-.005	.068		.051	1.772	-.000	.062	-.003	.128		13520	5960
KG-168	1.688	1.792		.068		.052	1.810		.062		.128		13810	6210
KG-175	1.750	1.858		.068		.054	1.876		.062		.128		14320	6680

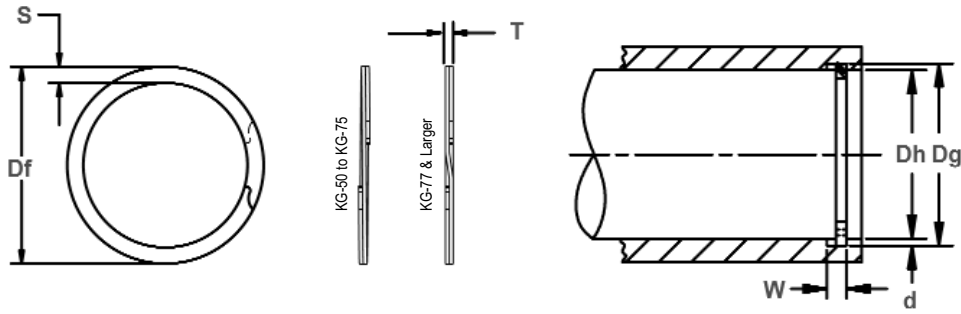

Free Diameter & Ring Measurements

Housing Diameter & Groove Dimensions

RING NO.	HOUSING DIAMETER		GROOVE SIZE				RING SIZE				SECTION		THRUST LOAD (lbs.)	
			DIAMETER		WIDTH		DEPTH		FREE DIAMETER				THICKNESS	
	Dh	Dg	Tol.	W	Tol.	d	Df	Tol.	T	Tol.	S	Tol.		
KG-181	1.812	1.922		.068		.055	1.940		.062		.128		14820	7050
KG-185	1.850	1.962	+.005	.068	+.004	.056	1.981	+.020	.062		.158	+.004	15130	7320
KG-187	1.875	1.989	-.005	.068	-.000	.057	2.008	-.000	.062		.158	-.004	15340	7560
KG-193	1.938	2.056		.068		.059	2.075		.062		.158		15850	8080
KG-200	2.000	2.122		.068		.061	2.142		.062		.158		16360	8620
KG-206	2.062	2.186		.086		.062	2.201		.078		.168		21220	9040
KG-212	2.125	2.251		.086		.063	2.267		.078		.168		21870	9460
KG-218	2.188	2.318		.086		.065	2.334		.078		.168		22520	10050
KG-225	2.250	2.382		.086		.066	2.399		.078		.168		23160	10500
KG-231	2.312	2.450		.086		.069	2.467	+.025	.078		.200		23800	11280
KG-237	2.375	2.517		.086		.071	2.535	-.000	.078		.200		24440	11920
KG-244	2.440	2.584		.086		.072	2.602		.078	+.003	.200		25110	12420
KG-250	2.500	2.648		.086		.074	2.667		.078	-.003	.200		25730	13080
KG-253	2.531	2.681		.086		.075	2.700		.078		.200		26050	13420
KG-256	2.562	2.714	+.006	.103	+.005	.076	2.733		.093		.225		29940	13760
KG-262	2.625	2.781	-.006	.103	-.000	.078	2.801		.093		.225		30680	14470
KG-268	2.688	2.848		.103		.080	2.868		.093		.225	+.005	31410	15200
KG-275	2.750	2.914		.103		.082	2.934	+.030	.093		.225	-.005	32140	15940
KG-281	2.813	2.980		.103		.084	3.001	-.000	.093		.225		32880	16700
KG-283	2.834	3.006		.103		.086	3.027		.093		.225		33120	17230
KG-287	2.875	3.051		.103		.088	3.072		.093		.225		33600	17880
KG-300	3.000	3.182		.103		.091	3.204		.093		.225		35060	18300
KG-306	3.062	3.248		.120		.093	3.271		.111		.281		42710	20130
KG-312	3.125	3.315		.120		.095	3.338		.111		.281		43590	20990
KG-315	3.157	3.348		.120		.096	3.371	+.035	.111		.281		44040	21420
KG-325	3.250	3.446		.120		.098	3.470	-.000	.111		.281		45330	22510
KG-334	3.346	3.546		.120		.100	3.571		.111		.281		46670	23650
KG-347	3.464	3.675		.120		.105	3.701		.111		.281		48320	25710

KG Spiral Housing Rings

Internal, Heavy Duty

The greatest size range and thrust capacity make these rings the only choice for applications that require minimum deflection or thrust loads that demand a deep groove capacity.

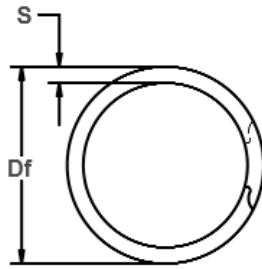

Free Diameter & Ring Measurements

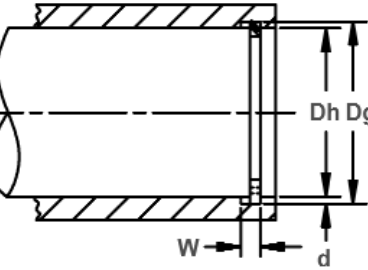
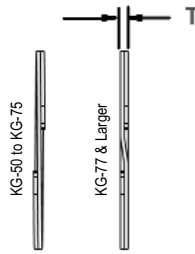

Housing Diameter & Groove Dimensions

RING NO.	HOUSING DIAMETER (In.)	GROOVE SIZE					RING SIZE					THURST LOAD (lbs.)		
		DIAMETER		WIDTH		DEPTH	FREE DIAMETER		THICKNESS		SECTION		RING Safety factor of 3	GROOVE Safety factor of 2
		Dh	Dg	Tol.	W	Tol.	d	Df	Tol.	T	Tol.	S		
KG-350	3.500	3.710		.120		.105	3.736		.111		.281		48820	25980
KG-354	3.543	3.755		.120		.106	3.781		.111		.281	+ .005	49420	26550
KG-356	3.562	3.776		.120		.107	3.802		.111		.281	- .005	49690	26940
KG-362	3.625	3.841		.120		.108	3.868		.111		.281		50560	27670
KG-375	3.750	3.974		.120		.112	4.002		.111		.312		52310	29690
KG-387	3.875	4.107	+ .006	.120	+ .005	.116	4.136	+ .035	.111	+ .003	.312		54050	31770
KG-393	3.938	4.174	- .006	.120	- .000	.118	4.203	- .000	.111	- .003	.312		54930	32850
KG-400	4.000	4.240		.120		.120	4.270		.111		.312		55800	33930
KG-412	4.125	4.365		.120		.120	4.395		.111		.312		57540	34990
KG-425	4.250	4.490		.120		.120	4.520		.111		.312		59280	36050
KG-433	4.330	4.570		.120		.120	4.600		.111		.312		60400	36730
KG-450	4.500	4.740		.120		.120	4.770		.111		.312		62770	38170
KG-462	4.625	4.865		.120		.120	4.899		.111		.312	+ .006	64510	39230
KG-475	4.750	4.995		.120		.123	5.030		.111		.312	- .006	66260	41300
KG-500	5.000	5.260		.120		.130	5.297		.111		.312		69740	45950
KG-525	5.250	5.520		.139		.135	5.559		.127		.350		83790	50100
KG-537	5.375	5.645	+ .007	.139	+ .006	.135	5.685	+ .050	.127	+ .004	.350		85780	51290
KG-550	5.500	5.770	- .007	.139	- .000	.135	5.810	- .000	.127	- .004	.350		87780	52480
KG-575	5.750	6.020		.139		.135	6.062		.127		.350		91770	54870
KG-600	6.000	6.270		.139		.135	6.314		.127		.350		95760	57260
KG-625	6.250	6.530		.174		.140	6.576		.156		.380		122520	61850
KG-650	6.500	6.790		.174		.145	6.838	+ .055	.156		.380		127420	66620
KG-662	6.625	6.925		.174		.150	6.974	- .000	.156		.380		129870	70240
KG-675	6.750	7.055	+ .008	.174	+ .008	.153	7.105		.156	+ .005	.380		132320	73000
KG-700	7.000	7.315	- .008	.174	- .000	.158	7.366		.156	- .005	.380		137230	78180
KG-725	7.250	7.575		.209		.163	7.628	+ .070	.187		.418	+ .007	170370	83530
KG-750	7.500	7.840		.209		.170	7.895	- .000	.187		.418	- .007	176240	90120
KG-775	7.750	8.100		.209		.175	8.157		.187		.418		182120	95870

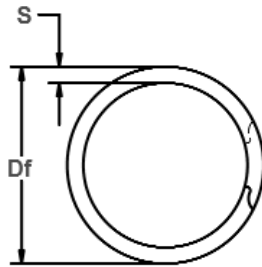

Free Diameter & Ring Measurements

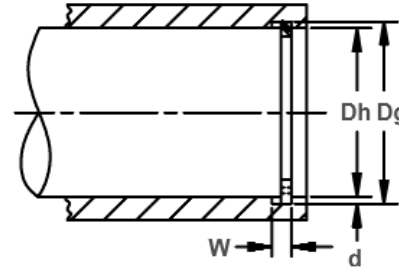
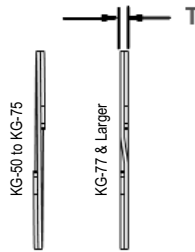

Housing Diameter & Groove Dimensions

RING NO.	HOUSING DIAMETER (In.)	GROOVE SIZE					RING SIZE						THRUST LOAD (lbs.)		
		DIAMETER		WIDTH		DEPTH	FREE DIAMETER			THICKNESS		SECTION		RING Safety factor of 3	GROOVE Safety factor of 2
		Dh	Dg	Tol.	W	Tol.	d	Df	Tol.	T	Tol.	S	Tol.		
KG-800	8.000	8.360		.209		.180	8.419		.187		.418		187990	101790	
KG-825	8.250	8.620		.209		.185	8.680		.187		.437		193870	107880	
KG-850	8.500	8.880		.209		.190	8.942		.187		.437		199740	114160	
KG-875	8.750	9.145	+ .008	.209		.198	9.209	+ .070	.187		.437		205620	122460	
KG-900	9.000	9.405	- .008	.209		.203	9.471	- .000	.187		.437		211490	129140	
KG-925	9.250	9.669		.209		.210	9.737		.187		.437	+ .007	217370	137310	
KG-950	9.500	9.930		.209		.215	10.000		.187		.500	- .007	223240	144380	
KG-975	9.750	10.189		.209		.220	10.260		.187		.500		229120	150620	
KG-1000	10.000	10.450		.209		.225	10.523		.187		.500		234990	159040	
KG-1025	10.250	10.711		.209		.235	10.786		.187		.500		246740	174420	
KG-1050	10.500	10.970		.209		.231	11.047		.187		.500		240870	167370	
KG-1075	10.750	11.234		.209	+ .008	.242	11.313		.187	+ .005	.500		252620	183890	
KG-1100	11.000	11.495		.209	- .000	.248	11.575		.187	- .005	.500		258490	192830	
KG-1125	11.250	11.756	+ .010	.209		.253	11.838		.187		.500		264370	201190	
KG-1150	11.500	12.018	- .010	.209		.259	12.102	+ .120	.187		.562		270240	210540	
KG-1175	11.750	12.279		.209		.265	12.365	- .000	.187		.562		276120	220100	
KG-1200	12.000	12.540		.209		.270	12.628		.187		.562		281990	229020	
KG-1225	12.250	12.801		.209		.276	12.891		.187		.562		287860	238990	
KG-1250	12.500	13.063		.209		.282	13.154		.187		.562		293740	249170	
KG-1275	12.750	13.324		.209		.287	13.417		.187		.562		299610	258660	
KG-1300	13.000	13.585		.209		.293	13.680		.187		.662	+ .015	305490	269240	
KG-1325	13.250	13.846		.209		.298	13.943		.187		.662	- .015	311360	279100	
KG-1350	13.500	14.108		.209		.304	14.207		.187		.662		317240	290100	
KG-1375	13.750	14.369	+ .012	.209		.310	14.470	+ .140	.187		.662		323110	301300	
KG-1400	14.000	14.630	- .012	.209		.315	14.732	- .000	.187		.662		328990	311730	
KG-1425	14.250	14.891		.209		.321	14.995		.187		.662		334860	323340	
KG-1450	14.500	15.153		.209		.327	15.259		.187		.750		340740	335160	
KG-1475	14.750	15.414		.209		.332	15.522		.187		.750		346610	346150	
KG-1500	15.000	15.675		.209		.338	15.785		.187		.750		352490	358380	

CG Spiral Shaft Rings

External, Heavy Duty

The rigors of the toughest applications are easily handled by this external series. Its large size, and ease of application and removal, transfers into an assurance of quality for demanding uses.

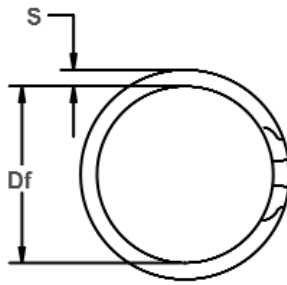

Free Diameter & Ring Measurements

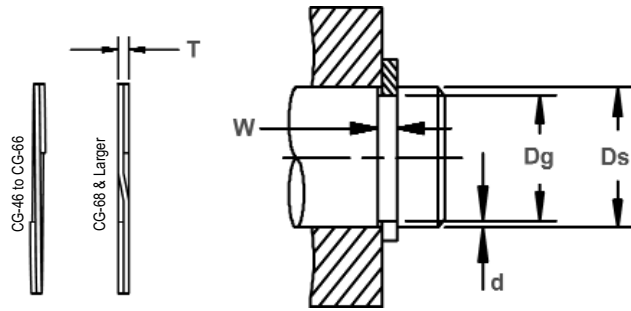

Shaft Diameter & Groove Dimensions

RING NO.	SHAFT DIAMETER (In.)	GROOVE SIZE					RING SIZE						THRUST LOAD (lbs.)		
		DIAMETER		WIDTH		DEPTH	FREE DIAMETER			THICKNESS		SECTION		RING Safety factor of 3	GROOVE Safety factor of 2
		Ds	Dg	Tol.	W	Tol.	d	Df	Tol.	T	Tol.	S	Tol.		
CG-46	.469	.443		.029		.013	.439		.025		.045		1880	430	
CG-50	.500	.468	+ .002	.039		.016	.464		.035		.050		2530	570	
CG-55	.551	.519	- .002	.039		.016	.514		.035		.050		2790	620	
CG-56	.562	.530		.039		.016	.525		.035		.050		2840	640	
CG-59	.594	.559		.039		.018	.554		.035		.050		3000	760	
CG-62	.625	.588		.039		.019	.583		.035		.055		3160	840	
CG-66	.669	.629		.039		.020	.623		.035		.055		3380	950	
CG-68	.688	.646		.046	+ .003	.021	.641		.042		.065		4180	1020	
CG-75	.750	.704	+ .003	.046	- .000	.023	.698		.042		.065		4550	1220	
CG-78	.781	.733	- .003	.046		.024	.727		.042		.065		4740	1330	
CG-81	.812	.762		.046		.025	.756	+ .000	.042	+ .002	.065	+ .004	4930	1440	
CG-87	.875	.821		.046		.027	.814	- .013	.042	- .002	.075	- .004	5310	1670	
CG-93	.938	.882		.046		.028	.875		.042		.075		5690	1860	
CG-98	.984	.926		.046		.029	.919		.042		.085		5970	2020	
CG-100	1.000	.940		.046		.030	.932		.042		.085		6070	2120	
CG-102	1.023	.961		.046		.031	.953		.042		.085		6210	2240	
CG-106	1.062	.998		.056		.032	.986		.050		.103		7010	2400	
CG-112	1.125	1.059		.056		.033	1.047		.050		.103		7420	2620	
CG-118	1.188	1.118		.056		.035	1.105		.050		.103		7840	2940	
CG-125	1.250	1.176	+ .004	.056	+ .004	.037	1.163		.050		.103		8250	3270	
CG-131	1.312	1.232	- .004	.056	- .000	.040	1.218		.050		.118		8660	3710	
CG-137	1.375	1.291		.056		.042	1.277		.050		.118		9070	4080	
CG-143	1.438	1.350		.056		.044	1.336		.050		.118		9490	4470	
CG-150	1.500	1.406		.056		.047	1.390		.050		.118		9900	4980	
CG-156	1.562	1.468	+ .005	.068		.047	1.453	+ .000	.062	+ .003	.128		12780	5190	
CG-162	1.625	1.529	- .005	.068		.048	1.513	- .020	.062	- .003	.128		13290	5510	

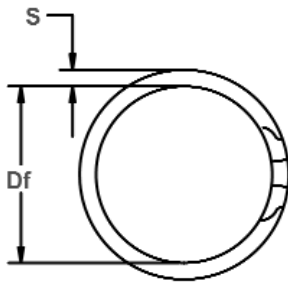

Free Diameter & Ring Measurements

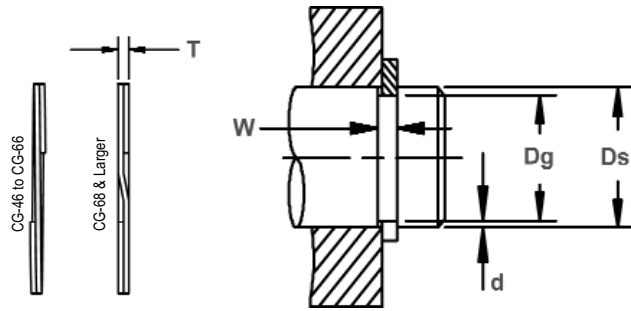

Shaft Diameter & Groove Dimensions

RING NO.	SHAFT DIAMETER (In.)	GROOVE SIZE					RING SIZE						THRUST LOAD (lbs.)		
		DIAMETER		WIDTH		DEPTH	FREE DIAMETER			THICKNESS		SECTION		RING Safety factor of 3	GROOVE Safety factor of 2
		Ds	Dg	Tol.	W	Tol.	d	Df	Tol.	T	Tol.	S	Tol.		
CG-168	1.687	1.589		.068		.049	1.573		.062		.128		13800	5840	
CG-175	1.750	1.650		.068		.050	1.633		.062		.128		14320	6190	
CG-177	1.771	1.669	+.005 -.005	.068	+.004 -.000	.051	1.651	+.000 -.020	.062		.128	+.004 -.004	14490	6380	
CG-181	1.812	1.708		.068		.052	1.690		.062		.128		14820	6660	
CG-187	1.875	1.769		.068		.053	1.751		.062		.158		15340	7020	
CG-196	1.969	1.857		.068		.056	1.838		.062		.158		16110	7790	
CG-200	2.000	1.886		.068		.057	1.867		.062		.158		16360	8060	
CG-206	2.062	1.946		.086		.058	1.932		.078		.168		21220	8450	
CG-212	2.125	2.003		.086		.061	1.989		.078		.168		21870	9160	
CG-215	2.156	2.032		.086		.062	2.018		.078		.168		22190	9450	
CG-225	2.250	2.120		.086		.065	2.105		.078		.168		23160	10340	
CG-231	2.312	2.178		.086		.067	2.163	+.000 -.025	.078	+.003 -.003	.168	+.005 -.005	23800	10950	
CG-237	2.375	2.239		.086		.068	2.223		.078		.200		24440	11420	
CG-243	2.437	2.299		.086		.069	2.283		.078		.200		25080	11890	
CG-250	2.500	2.360		.086		.070	2.343		.078		.200		25730	12370	
CG-255	2.559	2.419		.086		.070	2.402		.078		.200		26340	12660	
CG-262	2.625	2.481	+.006 -.006	.086	+.005 -.000	.072	2.464		.078		.200		27020	13360	
CG-268	2.687	2.541		.086		.073	2.523	.078	.200	27660	13870				
CG-275	2.750	2.602		.103		.074	2.584		.093		.225		32140	14390	
CG-287	2.875	2.721		.103		.077	2.702		.093		.225		33600	15650	
CG-293	2.937	2.779		.103		.079	2.760		.093		.225		34320	16400	
CG-300	3.000	2.838		.103		.081	2.818		.093		.225		35060	17180	
CG-306	3.062	2.898		.103		.082	2.878	+.000 -.030	.093		.225		35790	17750	
CG-312	3.125	2.957		.103		.084	2.936		.093	.225	36520	18560			
CG-315	3.156	2.986		.103		.085	2.965		.093		.225		36880	18960	
CG-325	3.250	3.076		.103		.087	3.054		.093		.225		37980	19990	
CG-334	3.344	3.166		.103		.089	3.144		.093		.225		39080	21040	
CG-343	3.437	3.257		.103		.090	3.234		.093		.225		40170	21870	

CG Spiral Shaft Rings

External, Heavy Duty

The rigors of the toughest applications are easily handled by this external series. Its large size, and ease of application and removal, transfers into an assurance of quality for demanding uses.

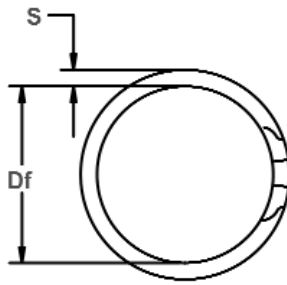

Free Diameter & Ring Measurements

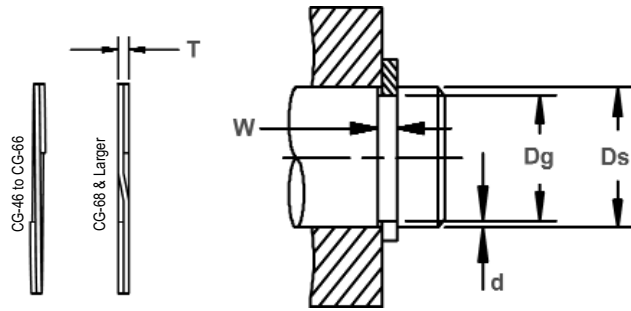

Shaft Diameter & Groove Dimensions

RING NO.	SHAFT DIAMETER (In.)	GROOVE SIZE					RING SIZE						THRUST LOAD (lbs.)		
		DIAMETER		WIDTH		DEPTH	FREE DIAMETER			THICKNESS		SECTION		RING Safety factor of 3	GROOVE Safety factor of 2
		Ds	Dg	Tol.	W	Tol.	d	Df	Tol.	T	Tol.	S	Tol.		
CG-350	3.500	3.316		.120		.092	3.293		.111		.270		48820	22760	
CG-354	3.543	3.357		.120		.093	3.333		.111		.270		49420	23290	
CG-362	3.625	3.435		.120		.095	3.411		.111		.270		50560	24340	
CG-368	3.687	3.493		.120		.097	3.469		.111		.270		51430	25280	
CG-375	3.750	3.552	+ .006	.120	+ .005	.099	3.527	+ .000	.111	+ .003	.270	+ .005	52310	26240	
CG-387	3.875	3.673	- .006	.120	- .000	.101	3.647	- .035	.111	- .003	.270	- .005	54050	27670	
CG-393	3.938	3.734		.120		.102	3.708		.111		.270		54930	28390	
CG-400	4.000	3.792		.120		.104	3.765		.111		.270		55800	29410	
CG-425	4.250	4.065		.120		.093	4.037		.111		.270		59280	27940	
CG-437	4.375	4.190		.120		.093	4.161		.111		.270		61030	28760	
CG-450	4.500	4.310		.120		.095	4.280		.111		.270		62770	30220	
CG-475	4.750	4.550		.120		.100	4.518		.111		.270		66260	36930	
CG-500	5.000	4.790		.120		.105	4.756		.111		.270		69740	37110	
CG-525	5.250	5.030		.139		.110	4.995		.127		.350		83790	40820	
CG-550	5.500	5.265	+ .007	.139	+ .006	.118	5.228	+ .000	.127	+ .004	.350	+ .006	87780	45880	
CG-575	5.750	5.505	- .007	.139	- .000	.123	5.466	- .050	.127	- .004	.350	- .006	91770	49990	
CG-600	6.000	5.745		.139		.128	5.705		.127		.350		95760	54290	
CG-625	6.250	5.985		.174		.133	5.938		.156		.418		122520	58760	
CG-650	6.500	6.225		.174		.138	6.181	+ .000	.156		.418		127420	63410	
CG-675	6.750	6.465		.174		.143	6.410	- .060	.156		.418		132330	68230	
CG-700	7.000	6.705		.174		.148	6.648		.156		.418		137230	73230	
CG-725	7.250	6.942	+ .008	.174	+ .008	.154	6.891		.156	+ .005	.418	+ .007	142130	78920	
CG-750	7.500	7.180	- .008	.209	- .000	.160	7.130		.187	- .005	.437	- .007	176240	84820	
CG-775	7.750	7.420		.209		.165	7.368	+ .000	.187		.437		182120	90390	
CG-800	8.000	7.660		.209		.170	7.606	- .070	.187		.437		187990	96130	
CG-825	8.250	7.900		.209		.175	7.845		.187		.437		193870	102050	
CG-850	8.500	8.140		.209		.180	8.083		.187		.437		199740	108150	

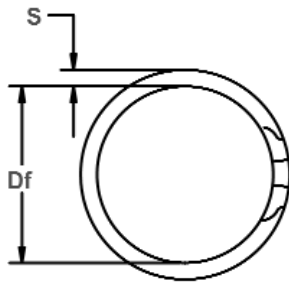

Free Diameter & Ring Measurements

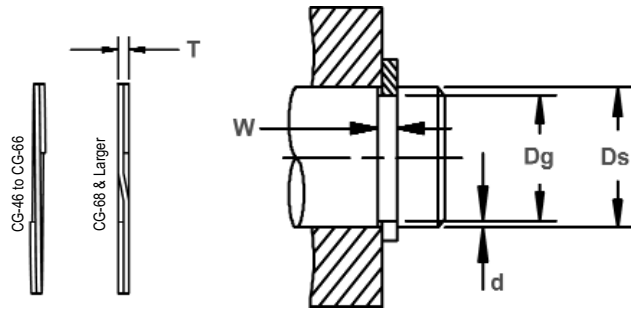

Shaft Diameter & Groove Dimensions

RING NO.	SHAFT DIAMETER (In.)	GROOVE SIZE					RING SIZE						THRUST LOAD (lbs.)		
		DIAMETER		WIDTH		DEPTH	FREE DIAMETER			THICKNESS		SECTION		RING Safety factor of 3	GROOVE Safety factor of 2
		Ds	Dg	Tol.	W	Tol.	d	Df	Tol.	T	Tol.	S	Tol.		
CG-875	8.750	8.383		.209		.184	8.324		.187		.437		205620	113800	
CG-900	9.000	8.620		.209		.190	8.560		.187		.500		211490	120870	
CG-925	9.250	8.860	+.008	.209		.195	8.798	+.000	.187		.500		217370	127500	
CG-950	9.500	9.100	-.008	.209		.200	9.036	-.070	.187		.500		223240	134300	
CG-975	9.750	9.338		.209		.206	9.275		.187		.500	+.007	229120	141970	
CG-1000	10.000	9.575		.209		.213	9.508		.187		.500	-.007	234990	150560	
CG-1025	10.250	9.814		.209		.218	9.745		.187		.500		240870	157950	
CG-1050	10.500	10.054		.209		.223	9.984		.187		.500		246740	165510	
CG-1075	10.750	10.293		.209		.229	10.221		.187		.500		252620	174010	
CG-1100	11.000	10.533		.209		.234	10.459		.187		.500		258490	181950	
CG-1125	11.250	10.772	+.010	.209	+.008	.239	10.692	+.000	.187	+.005	.500		264360	190060	
CG-1150	11.500	11.011	-.010	.209	-.000	.245	10.934	-.090	.187	-.005	.562		270240	199160	
CG-1175	11.750	11.250		.209		.250	11.171		.187		.562		276120	207640	
CG-1200	12.000	11.490		.209		.255	11.410		.187		.562		281990	216300	
CG-1225	12.250	11.729		.209		.261	11.647		.187		.562		287860	226000	
CG-1250	12.500	11.969		.209		.266	11.885		.187		.562		293740	235030	
CG-1275	12.750	12.208		.209		.271	12.124		.187		.562		299610	244240	
CG-1300	13.000	12.448		.209		.276	12.361		.187		.662	+.015	305490	253620	
CG-1325	13.250	12.687		.209		.282	12.598		.187		.662	-.010	311360	264120	
CG-1350	13.500	12.927		.209		.287	12.837		.187		.662		317240	273870	
CG-1375	13.750	13.166	+.012	.209		.292	13.074	+.000	.187		.662		323110	283800	
CG-1400	14.000	13.405	-.012	.209		.298	13.311	-.110	.187		.662		328990	294900	
CG-1425	14.250	13.644		.209		.303	13.548		.187		.662		334860	305200	
CG-1450	14.500	13.884		.209		.308	13.787		.187		.750		340740	315680	
CG-1475	14.750	14.123		.209		.314	14.024		.187		.750		346610	327380	
CG-1500	15.000	14.363		.209		.319	14.262		.187		.750		352490	338230	

KLR Spiral Housing Rings

Internal, Heavy-Duty Snap Ring

These single-turn snap rings are ideal for applications involving high thrust loads.

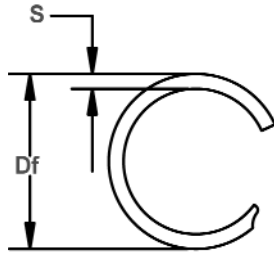

Free Diameter & Ring Measurements

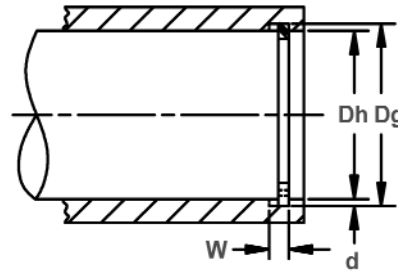
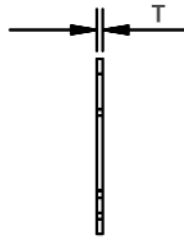

Housing Diameter & Groove Dimensions

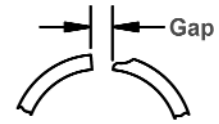

Optional End Designs

RING NO.	HOUSING DIAMETER (In.)	GROOVE SIZE				RING SIZE						THRUST LOAD (lbs.)	
		DIAMETER		WIDTH		FREE DIAMETER		THICKNESS		SECTION		RING Safety factor of 3	GROOVE Safety factor of 2
		Dh	Dg	Tol.	W	Tol.	Df	Tol.	T	Tol.	S		
KLR-50	.500	.524		.043		.529		.037		.055		2325	424
KLR-56	.562	.586	+.004	.043		.591		.037		.055		2613	477
KLR-62	.625	.657	-.000	.043		.665	+.013	.037		.065		2906	707
KLR-68	.687	.719		.043		.726	-.000	.037		.065		3194	777
KLR-75	.750	.790	+.005	.043		.797		.037		.075		3487	1060
KLR-81	.812	.852	-.000	.043		.860		.037		.075		3775	1148
KLR-87	.875	.915		.043		.924		.037		.075		4068	1237
KLR-93	.937	.985		.051		1.000		.045		.085		5334	1590
KLR-100	1.000	1.048	+.008	.051		1.058		.045		.085		5693	1696
KLR-106	1.062	1.110	-.000	.051		1.121		.045		.094		6045	1802
KLR-112	1.125	1.181		.051		1.192		.045	±.002	.094	±.004	6404	2227
KLR-118	1.187	1.243		.051		1.252	+.015	.045		.094		6757	2349
KLR-125	1.250	1.316		.051		1.336	-.000	.045		.094		7116	2916
KLR-131	1.312	1.378		.051		1.391		.045		.094		7469	3060
KLR-137	1.375	1.453		.063		1.470		.057		.128		9307	3791
KLR-143	1.437	1.515	+.010	.063		1.529		.057		.128		9727	3961
KLR-150	1.500	1.578	-.000	.063		1.592		.057		.128		10153	4135
KLR-156	1.562	1.666		.073		1.687		.067		.158		12400	5741
KLR-162	1.625	1.729		.073	+.006	1.746		.067		.158		12901	5973
KLR-168	1.687	1.791		.073	-.000	1.808	+.020	.067		.158		13393	6201
KLR-175	1.750	1.862		.073		1.885	-.000	.067		.158		13893	6927
KLR-181	1.812	1.924		.073		1.942		.067		.158		14385	7173
KLR-187	1.875	1.987		.073		2.007		.067		.158		14885	7422
KLR-193	1.937	2.055		.085		2.074		.076		.200		16649	8078
KLR-200	2.000	2.118		.085		2.143		.076		.200		17191	8341
KLR-206	2.062	2.180		.085		2.200		.076		.200		17724	8599
KLR-212	2.125	2.243		.085		2.264		.076		.200		18265	8862
KLR-218	2.187	2.305		.085		2.327	+.025	.076		.200		18798	9121
KLR-225	2.250	2.368		.085		2.389	-.000	.076		.200		19340	9384
KLR-231	2.312	2.430	+.012	.085		2.453		.076		.200		19873	9642
KLR-237	2.375	2.493	-.000	.085		2.517		.076		.200		20414	9905
KLR-243	2.437	2.555		.085		2.582		.076		.200		20947	10163
KLR-250	2.500	2.618		.085		2.643		.076		.200		21488	10426
KLR-256	2.562	2.680		.104		2.705		.095		.200		26225	10685
KLR-262	2.625	2.743		.104		2.777		.095	±.003	.200	±.005	26870	10947
KLR-268	2.687	2.805		.104		2.828		.095		.200		27504	11206
KLR-275	2.750	2.868		.104		2.899		.095		.200		28149	11469
KLR-281	2.812	2.930		.104		2.958	+.030	.095		.200		28784	11727
KLR-287	2.875	2.993		.104		3.022	-.000	.095		.200		29429	11990
KLR-293	2.937	3.055		.104		3.084		.095		.200		30063	12249
KLR-300	3.000	3.118		.104		3.145		.095		.200		30708	12511
KLR-306	3.062	3.184		.104		3.218		.095		.200		31343	13203
KLR-312	3.125	3.263	+.013	.104		3.294		.095		.237		31988	15242
KLR-318	3.187	3.325	-.000	.104		3.357		.095		.237		32622	15544
KLR-325	3.250	3.388		.104		3.420		.095		.237		33267	15851

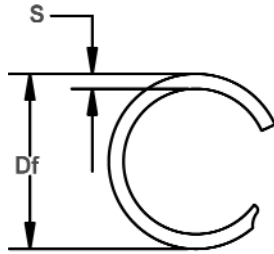

Free Diameter & Ring Measurements

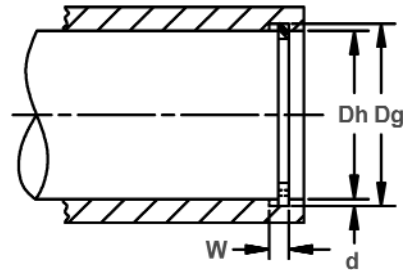
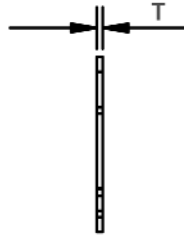

Housing Diameter & Groove Dimensions

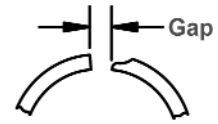

Optional End Designs

RING NO.	HOUSING DIAMETER (In.)	GROOVE SIZE				RING SIZE						THRUST LOAD (lbs.)	
		DIAMETER		WIDTH		FREE DIAMETER		THICKNESS		SECTION		RING Safety factor of 3	GROOVE Safety factor of 2
		Dg	Tol.	W	Tol.	Df	Tol.	T	Tol.	S	Tol.		
KLR-331	3.312	3.450		.124		3.483		.115		.248		38952	16154
KLR-337	3.375	3.513		.124		3.547		.115		.248		39693	16461
KLR-343	3.437	3.575		.124		3.609		.115		.248		40422	16763
KLR-350	3.500	3.638		.124		3.673		.115		.248		41163	17071
KLR-356	3.562	3.700	+.013 -.000	.124		3.728	+.035 -.000	.115	±.003	.248		41892	17373
KLR-362	3.625	3.763		.124	3.799	.115		.248					
KLR-368	3.687	3.825	.124	3.862	.115	.248							
KLR-375	3.750	3.888	.124	3.922	.115	.248							
KLR-381	3.812	3.950	.124	3.988	.115	.248							
KLR-387	3.875	4.013	.124	4.044	.115	.248							
KLR-393	3.937	4.075	.124	4.114	.115	.248							
KLR-400	4.000	4.158	+.021 -.000	.163		4.223	+.050 -.000	.153	±.004	.265	±.005	60283	22337
KLR-412	4.125	4.283		.163	4.329	.153		.265					
KLR-425	4.250	4.408	.163	4.452	.153	.265							
KLR-437	4.375	4.533	.163	4.576	.153	.265							
KLR-450	4.500	4.658	.163	4.703	.153	.265							
KLR-462	4.625	4.783	+.024 -.000	.163		4.829	+.070 -.000	.153	±.005	.265	±.006	69702	25827
KLR-475	4.750	4.908		.163	4.945	.153		.265					
KLR-487	4.875	5.033	.163	5.082	.153	.265							
KLR-500	5.000	5.158	.163	5.207	.153	.265							
KLR-525	5.250	5.408	+.028 -.000	.163	+.007 -.000	5.460	+.055 -.000	.153	±.004	.265	±.005	79121	29317
KLR-550	5.500	5.658		.163		5.719		.153		.265			
KLR-575	5.750	5.908	.163	5.965	.153	.265							
KLR-600	6.000	6.196	.163	6.256	.153	.316	+.070 -.000	±.005	.316	±.007	90424	41563	
KLR-625	6.250	6.446	.163	6.508	.153	.316							
KLR-650	6.500	6.696	.163	6.760	.153	.316	+.120-.000	.192	.435	.435	97959	45027	
KLR-675	6.750	6.946	.163	7.013	.153	.316							
KLR-700	7.000	7.196	+.031 -.000	.163		7.266	+.070 -.000	±.005	.316	±.006	101727	46759	
KLR-725	7.250	7.446		.163	7.541	.153					.316		
KLR-750	7.500	7.696	.163	7.762	.153	.316	+.070 -.000	±.005	.316	±.007	105494	48490	
KLR-775	7.750	7.946	.163	8.023	.153	.316							
KLR-800	8.000	8.196	+.028 -.000	.163		8.276	+.070 -.000	±.005	.316	±.006	109262	50222	
KLR-825	8.250	8.486		.203	8.580	.192					.373		
KLR-850	8.500	8.736	.203	8.821	.192	.373	+.070 -.000	±.005	.373	±.007	113030	51954	
KLR-875	8.750	8.986	.203	9.073	.192	.373							
KLR-900	9.000	9.236	.203	9.326	.192	.373	+.070 -.000	±.005	.373	±.007	116797	53686	
KLR-925	9.250	9.486	.203	9.580	.192	.373							
KLR-950	9.500	9.736	.203	9.831	.192	.373	+.070 -.000	±.005	.373	±.007	147399	68813	
KLR-975	9.750	9.986	.203	10.083	.192	.373							
KLR-1000	10.000	10.314	+.031 -.000	.203		10.414	+.070 -.000	±.005	.435	±.007	151866	70898	
KLR-1025	10.250	10.564		.203	10.660	.192					.373		
KLR-1050	10.500	10.814	.203	10.919	.192	.435	+.070 -.000	±.005	.435	±.007	156332	72983	
KLR-1075	10.750	11.064	.203	11.171	.192	.435							
KLR-1100	11.000	11.314	.203	11.440	+.120-.000	.192			.435		160799	75068	
												165265	77154
												169732	79239
												174199	81324
												178665	110977
												183132	113751
												187599	116526
												192065	119300
												196532	122074

CLR Spiral Shaft Rings

External, Heavy-Duty Snap Ring

These single-turn snap rings are ideal for applications involving high thrust loads.

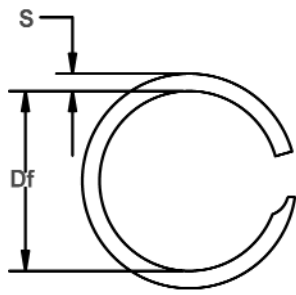

Free Diameter & Ring Measurements

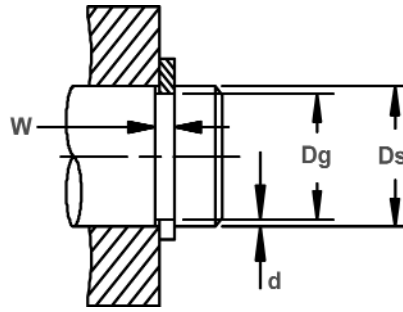

Shaft Diameter & Groove Dimensions

Optional End Designs

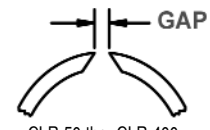

CLR-50 thru CLR-400

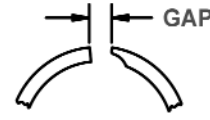

CLR-412 thru CLR-1100

RING NO.	SHAFT DIAMETER (In.)	GROOVE SIZE				RING SIZE						THRUST LOAD (lbs.)	
		DIAMETER		WIDTH		FREE DIAMETER		THICKNESS		SECTION		RING Safety factor of 3	GROOVE Safety factor of 2
		Ds	Dg	Tol.	W	Tol.	Df	Tol.	T	Tol.	S		
CLR-50	.500	.476		.043		.471		.037		.055		2325	424
CLR-56	.562	.532	+ .000	.043		.524		.037		.055		2613	596
CLR-62	.625	.595	- .004	.043		.590		.037		.065		2906	663
CLR-68	.687	.655		.043		.649		.037		.065		3194	777
CLR-75	.750	.710		.051		.701	+ .000	.045		.075		4241	1060
CLR-81	.812	.772	+ .000	.051		.764	- .013	.045		.075		4592	1148
CLR-87	.875	.831	- .005	.051		.820		.045		.075		4948	1361
CLR-93	.937	.893		.051		.886		.045		.085		5334	1457
CLR-100	1.000	.952	+ .000	.051		.933		.045		.085		5693	1696
CLR-106	1.062	1.014	- .008	.051		1.004		.045	± .002	.085	+ .003	6045	1802
CLR-112	1.125	1.077		.063		1.069		.057		.128	- .005	7615	1909
CLR-118	1.187	1.131		.063		1.116		.057		.128		8035	2349
CLR-125	1.250	1.188		.063		1.176	+ .000	.057		.128		8461	2739
CLR-131	1.312	1.242		.063		1.223	- .015	.057		.128		8881	3246
CLR-137	1.375	1.297		.063		1.282		.057		.128		9307	3791
CLR-143	1.437	1.359		.073		1.344		.067		.158		11408	3961
CLR-150	1.500	1.422		.073		1.402		.067		.158		11908	4135
CLR-156	1.562	1.470	+ .000	.073	+ .006	1.457		.067		.158		12400	5079
CLR-162	1.625	1.533	- .010	.073	- .000	1.517		.067		.158		12901	5284
CLR-168	1.687	1.595		.073		1.578	+ .000	.067		.158		13393	5485
CLR-175	1.750	1.658		.073		1.640	- .020	.067		.158		13893	5690
CLR-181	1.812	1.720		.073		1.697		.067		.158		14385	5892
CLR-187	1.875	1.783		.073		1.767		.067		.158		14885	6097
CLR-193	1.937	1.819		.085		1.800		.076		.200		16649	8078
CLR-200	2.000	1.882		.085		1.862		.076		.200		17191	8341
CLR-206	2.062	1.944		.085		1.924		.076		.200		17724	8599
CLR-212	2.125	2.007		.085		1.987		.076		.200		18265	8862
CLR-218	2.187	2.069		.085		2.048		.076		.200		18798	9121
CLR-225	2.250	2.132		.085		2.110	+ .000	.076		.200		19340	9384
CLR-231	2.312	2.194		.085		2.171	- .025	.076		.200		19873	9642
CLR-237	2.375	2.257		.085		2.226		.076		.200	+ .004	20414	9905
CLR-243	2.437	2.319		.085		2.296		.076		.200	- .006	20947	10163
CLR-250	2.500	2.382		.085		2.357		.076		.200		21488	10426
CLR-256	2.562	2.444	+ .000	.104		2.415		.095	± .003	.200		26252	10685
CLR-262	2.625	2.507	- .012	.104		2.486		.095		.200		26898	10947
CLR-268	2.687	2.569		.104		2.537		.095		.200		27533	11206
CLR-275	2.750	2.632		.104		2.607		.095		.200		28179	11469
CLR-281	2.812	2.694		.104		2.665		.095		.200		28814	11727
CLR-287	2.875	2.757		.104		2.727		.095		.200		29460	11990
CLR-293	2.937	2.819		.104		2.789	+ .000	.095		.200		30095	12249
CLR-300	3.000	2.882		.104		2.852	- .030	.095		.200		30740	12511
CLR-306	3.062	2.944		.104		2.916		.095		.200		31376	12770
CLR-312	3.125	2.987		.104		2.955		.095		.237		32021	15242
CLR-318	3.187	3.049		.104		3.016		.095		.237	± .005	32657	15544
CLR-325	3.250	3.112		.104		3.079		.095		.237		33302	15851

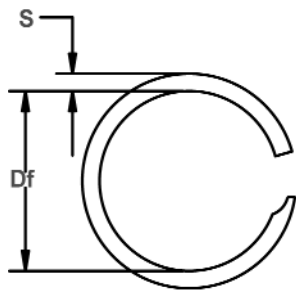

Free Diameter & Ring Measurements

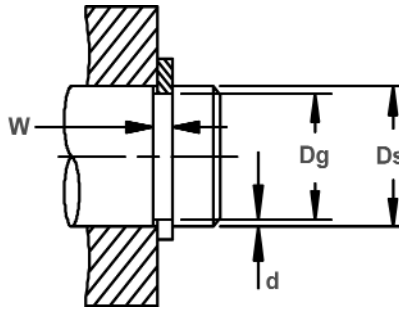

Shaft Diameter & Groove Dimensions

Optional End Designs

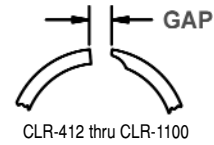
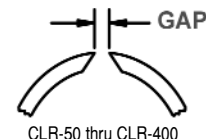

RING NO.	SHAFT DIAMETER (In.)	GROOVE SIZE				RING SIZE						THRUST LOAD (lbs.)	
		DIAMETER		WIDTH		FREE DIAMETER		THICKNESS		SECTION		RING Safety factor of 3	GROOVE Safety factor of 2
		Ds	Dg	Tol.	W	Tol.	Df	Tol.	T	Tol.	S		
CLR-331	3.312	3.174		.124		3.140	+ .000-.030	.115		.248		39088	16154
CLR-337	3.375	3.237		.124		3.203		.115		.248		39831	16461
CLR-343	3.437	3.299		.124		3.264		.115		.248		40563	16763
CLR-350	3.500	3.362		.124		3.326		.115		.248		41307	17071
CLR-356	3.562	3.424		.124		3.378		.115		.248		42038	17373
CLR-362	3.625	3.487	+ .000	.124		3.451	+ .000	.115	± .003	.248		42782	17680
CLR-368	3.687	3.549	- .014	.124		3.512	- .035	.115		.248		43514	17983
CLR-375	3.750	3.612		.124		3.570		.115		.248		44257	18290
CLR-381	3.812	3.674		.124		3.636		.115		.248		44989	18592
CLR-387	3.875	3.737		.124		3.689		.115		.248		45732	18900
CLR-393	3.937	3.799		.124		3.760		.115		.248	± .005	46464	19202
CLR-400	4.000	3.862		.124		3.828		.115		.248		47208	19509
CLR-412	4.125	3.967	+ .000	.163		3.930		.153		.265		62126	23035
CLR-425	4.250	4.092	- .021	.163		4.050		.153		.265		64008	23733
CLR-437	4.375	4.217		.163		4.174		.153		.265		65891	24431
CLR-450	4.500	4.342		.163		4.297	+ .000	.153		.265		67774	25129
CLR-462	4.625	4.467		.163		4.421	- .051	.153		.265		69656	25827
CLR-475	4.750	4.592		.163		4.530		.153		.265		71539	26525
CLR-487	4.875	4.717		.163		4.668		.153		.265		73421	27223
CLR-500	5.000	4.842		.163		4.792		.153		.265		75304	27921
CLR-525	5.250	5.092	+ .000	.163	+ .007	5.039		.153	± .004	.265		79069	29317
CLR-550	5.500	5.342	- .024	.163	- .000	5.292		.153		.265		82834	30713
CLR-575	5.750	5.592		.163		5.535		.153		.265		86599	32109
CLR-600	6.000	5.804		.163		5.744		.153		.316		90365	41563
CLR-625	6.250	6.054		.163		5.992	+ .000	.153		.316		94130	43295
CLR-650	6.500	6.304		.163		6.236	- .060	.153		.316	± .006	97985	45027
CLR-675	6.750	6.554		.163		6.486		.153		.316		101727	46759
CLR-700	7.000	6.804		.163		6.734		.153		.316		105494	48490
CLR-725	7.250	7.054		.163		6.993		.153		.316		109262	50222
CLR-750	7.500	7.304		.163		7.219		.153		.316		113030	51954
CLR-775	7.750	7.554		.163		7.477		.153		.316		116797	53686
CLR-800	8.000	7.764	+ .000	.203		7.683	+ .000	.192		.435		142932	66727
CLR-825	8.250	8.014	- .028	.203		7.940	- .070	.192		.435		147399	68813
CLR-850	8.500	8.264		.203		8.179		.192		.435		151866	70898
CLR-875	8.750	8.514		.203		8.427		.192		.435		156332	72983
CLR-900	9.000	8.764		.203		8.673		.192		.435		160799	75068
CLR-925	9.250	9.014		.203		8.922		.192		.435	± .007	165265	77154
CLR-950	9.500	9.240		.203		9.130		.192	± .005	.435		169732	87297
CLR-975	9.750	9.490		.203		9.393		.192		.435		174199	98594
CLR-1000	10.000	9.686		.203		9.586		.192		.500		178665	110977
CLR-1025	10.250	9.936	+ .000	.203		9.826	+ .000	.192		.500		183132	113751
CLR-1050	10.500	10.186	- .031	.203		10.081	- .091	.192		.500		187599	116526
CLR-1075	10.750	10.436		.203		10.329		.192		.500		192056	119300
CLR-1100	11.000	10.686		.203		10.584		.192		.500		196532	122074



DKR Spiral Housing Rings

DIN 472

Internal, Heavy Duty DIN

An internal metric ring which meets DIN standards of performance and quality. Our metric rings come standard in 302 stainless steel.

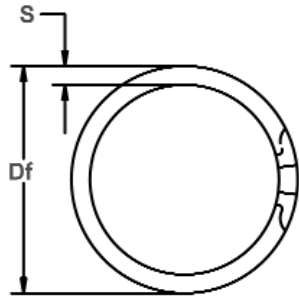

Free Diameter & Ring Measurements

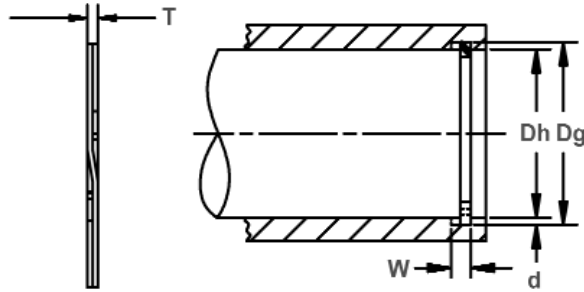

Housing Diameter & Groove Dimensions

RING NO.	HOUSING DIAMETER (mm)	GROOVE SIZE					RING SIZE					THRUST LOAD (N)				
		DIAMETER			WIDTH		DEPTH	FREE DIAMETER			THICKNESS		SECTION		RING Safety factor of 3	GROOVE Safety factor of 2
		Dh	Dg	Tol.	W	Tol.	d	Df	Tol.	T	Tol.	S	Tol.			
DKR-13	13	13,6		1,10		0,3	13,72		0,99		1,40		13474	1901		
DKR-14	14	14,6	+0,11	1,10		0,3	14,75		0,99		1,40		14510	2047		
DKR-15	15	15,7	-0,00	1,10		0,4	15,85		0,99		1,40		15547	2559		
DKR-16	16	16,8		1,10		0,4	16,97		0,99		1,65		16583	3119		
DKR-17	17	17,8		1,10		0,4	17,98	+0,33	0,99		1,65		17620	3314		
DKR-18	18	19,0		1,10		0,5	19,18	-0,00	0,99		1,91		18656	4386		
DKR-19	19	20,0	+0,13	1,10		0,5	20,19		0,99		1,91		19693	4630		
DKR-20	20	21,0	-0,00	1,10		0,5	21,21		0,99		1,91		20729	4874		
DKR-21	21	22,0		1,10		0,5	22,23		0,99		1,91		21766	5117		
DKR-22	22	23,0		1,10		0,5	23,23		0,99		1,91		22802	5361		
DKR-23	23	24,1		1,30		0,6	24,33		1,14		2,18		23853	6165		
DKR-24	24	25,2		1,30	+0,14	0,6	25,45		1,14	±0,05	2,18	±0,10	24891	7018		
DKR-25	25	26,2	+0,21	1,30	-0,00	0,6	26,45		1,14		2,18		25928	7310		
DKR-26	26	27,2	-0,00	1,30		0,6	27,48		1,14		2,18		26965	7603		
DKR-27	27	28,4		1,30		0,7	28,68		1,14		2,41		28002	9211		
DKR-28	28	29,4		1,30		0,7	29,69		1,14		2,41		29039	9552		
DKR-29	29	30,4		1,30		0,7	30,71		1,14		2,41		30076	9893		
DKR-30	30	31,4		1,30		0,7	31,71	+0,38	1,14		2,41		31113	10235		
DKR-31	31	32,7		1,30		0,9	33,02	-0,00	1,14		2,41		32150	12842		
DKR-32	32	33,7		1,30		0,9	34,04		1,14		2,41		33187	13256		
DKR-33	33	34,7	+0,25	1,30		0,9	35,05		1,14		2,41		34224	13670		
DKR-34	34	35,7	-0,00	1,60		0,9	36,07		1,44		3,25		44541	14085		
DKR-35	35	37,0		1,60		1,0	37,38		1,44		3,25		45851	17058		
DKR-36	36	38,0		1,60		1,0	38,39		1,44		3,25		47161	17545		
DKR-37	37	39,0		1,60		1,0	39,40		1,44		3,25		48471	18032		
DKR-38	38	40,0		1,60		1,0	40,41		1,44		3,25		49781	18520		

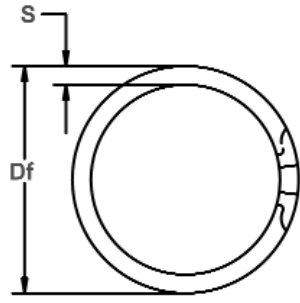

Free Diameter & Ring Measurements

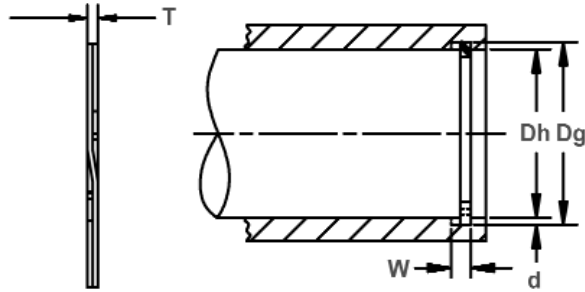

Housing Diameter & Groove Dimensions

RING NO.	HOUSING DIAMETER (mm)	GROOVE SIZE					RING SIZE						THRUST LOAD (N)			
		DIAMETER			WIDTH		DEPTH	FREE DIAMETER			THICKNESS		SECTION		RING Safety factor of 3	GROOVE Safety factor of 2
		Dh	Dg	Tol.	W	Tol.	d	Df	Tol.	T	Tol.	S	Tol.			
DKR-40	40	42,5	+0,25 -0,00	1,85	+0,14 -0,00	1,3	42,93	+0,51 -0,00	1,69	±0,05	4,01	±0,10	61498	24368		
DKR-41	41	43,5		1,85		1,3	43,94		1,69		4,01		63036	24977		
DKR-42	42	44,5		1,85		1,3	44,96		1,69		4,01		64573	25586		
DKR-45	45	47,5		1,85		1,3	47,98		1,69		4,01		69186	27414		
DKR-47	47	49,5	+0,30 -0,00	1,85	+0,14 -0,00	1,3	49,99	+0,63 -0,00	1,69	±0,08	4,01	±0,12	72261	28633		
DKR-48	48	50,5		1,85		1,3	51,00		1,69		4,01		73798	29242		
DKR-50	50	53,0		2,15		1,5	53,54		1,93		5,08		87790	36552		
DKR-51	51	54,0		2,15		1,5	54,54		1,93		5,08		89546	37283		
DKR-52	52	55,0		2,15		1,5	55,55		1,93		5,08		91302	38014		
DKR-55	55	58,0		2,15		1,5	58,57		1,93		5,08		96569	40207		
DKR-56	56	59,0		2,15		1,5	59,59		1,93		5,08		98325	40938		
DKR-57	57	60,0		2,15		1,5	60,60		1,93		5,08		100081	41669		
DKR-58	58	61,0	+0,35 -0,00	2,15	+0,14 -0,00	1,5	61,62	+0,76 -0,00	1,93	±0,08	5,08	±0,13	101836	42400		
DKR-60	60	63,0		2,15		1,5	63,63		1,93		5,08		105348	43863		
DKR-62	62	65,0		2,15		1,5	65,66		1,93		5,08		108860	45325		
DKR-63	63	66,0		2,15		1,5	66,67		1,93		5,08		110615	46056		
DKR-64	64	67,0		2,15		1,5	67,67		1,93		5,08		112371	46787		
DKR-65	65	68,0		2,65		1,5	68,67		2,41		5,08		135725	47518		
DKR-67	67	70,0		2,65		1,5	70,67		2,41		5,08		139901	48980		
DKR-68	68	71,0		2,65		1,5	71,67		2,41		5,08		141989	49711		
DKR-70	70	73,0		2,65		1,5	73,67		2,41		5,08		146165	51173		
DKR-72	72	75,0		2,65		1,5	75,67		2,41		5,08		150341	52635		
DKR-75	75	78,0		2,65		1,5	78,68		2,41		5,08		156605	54828		
DKR-76	76	79,0		2,65		1,5	79,68		2,41		5,08		158694	55559		
DKR-78	78	81,0	+0,35 -0,00	2,65	+0,14 -0,00	1,5	81,69	+0,76 -0,00	2,41	±0,08	5,08	±0,13	162870	57021		
DKR-80	80	83,5		2,65		1,8	84,19		2,41		6,05		167046	68231		



DKR Spiral Housing Rings

DIN 472

Internal, Heavy Duty DIN

An internal metric ring which meets DIN standards of performance and quality. Our metric rings come standard in 302 stainless steel.

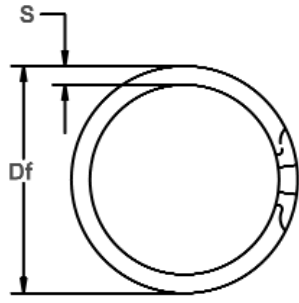

Free Diameter & Ring Measurements

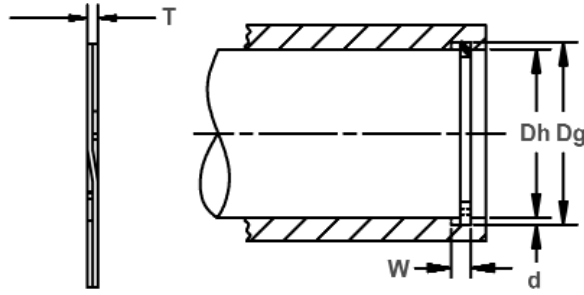

Housing Diameter & Groove Dimensions

RING NO.	HOUSING DIAMETER (mm)	GROOVE SIZE					RING SIZE						THRUST LOAD (N)			
		DIAMETER			WIDTH		DEPTH	FREE DIAMETER			THICKNESS		SECTION		RING Safety factor of 3	GROOVE Safety factor of 2
		Dh	Dg	Tol.	W	Tol.	d	Df	Tol.	T	Tol.	S	Tol.			
DKR-82	82	85,5		2,65	+0,14 -0,00	1,8	86,20	+0,76 -0,00	2,41		6,05		171222	69936		
DKR-85	85	88,5		3,15		1,8	89,20		2,91		6,05		214309	72495		
DKR-88	88	91,5	+0,35	3,15		1,8	92,21		2,91		6,05		221873	75054		
DKR-90	90	93,5	-0,00	3,15		1,8	94,21	+0,89	2,91	±0,08	6,05		226915	76759		
DKR-92	92	95,5		3,15		1,8	96,22	-0,00	2,91		6,05		231958	78465		
DKR-95	95	98,5		3,15		1,8	99,24		2,91		6,05		239522	81024		
DKR-98	98	101,5		3,15		1,8	102,26		2,91		6,05		247068	83583		
DKR-100	100	103,5		3,15		1,8	104,29		2,91		6,05		252128	85288		
DKR-102	102	106,0		4,15		2,0	106,79		3,89		6,73		343778	99422		
DKR-105	105	109,0		4,15		2,0	109,79		3,89		6,73	±0,13	353889	102346		
DKR-108	108	112,0	+0,54	4,15		2,0	112,80		3,89		6,73		364000	105270		
DKR-110	110	114,0	-0,00	4,15		2,0	114,83		3,89		6,73		370741	107220		
DKR-112	112	116,0		4,15	+0,18	2,0	116,84		3,89		6,73		377482	109169		
DKR-115	115	119,0	-0,00	4,15	-0,00	2,0	119,86	+1,30	3,89		6,73		387593	112093		
DKR-120	120	124,0		4,15		2,0	124,92	-0,00	3,89		6,73		404445	116967		
DKR-125	125	129,0		4,15		2,0	129,97		3,89		6,73		421297	121840		
DKR-127	127	131,0		4,15		2,0	131,97		3,89	±0,10	6,73		428038	123790		
DKR-130	130	134,0		4,15		2,0	135,00		3,89		6,73		438149	126714		
DKR-135	135	139,0	+0,63	4,15		2,0	140,03		3,89		6,73		455001	131588		
DKR-140	140	144,0	-0,00	4,15		2,0	145,11		3,89		6,73		471852	136461		
DKR-145	145	149,0		4,15		2,0	150,11		3,89		6,73		488704	141335		
DKR-150	150	155,0		4,15		2,5	156,13		3,89		7,92		505556	182761		
DKR-155	155	160,0		4,15		2,5	161,19	+1,40	3,89		7,92		522408	188853		
DKR-160	160	165,0		4,15		2,5	166,22	-0,00	3,89		7,92	±0,15	539260	194945		
DKR-165	165	170,0		4,15		2,5	171,27		3,89		7,92		556112	201037		
DKR-170	170	175,0		4,15		2,5	176,33		3,89		7,92		572964	207129		

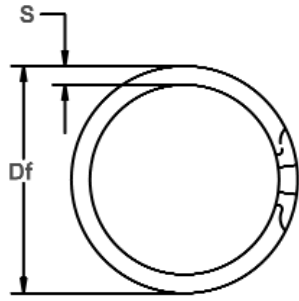

Free Diameter & Ring Measurements

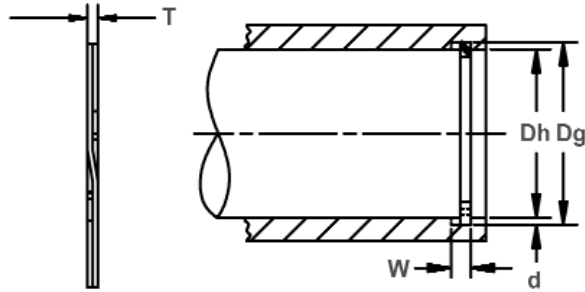

Housing Diameter & Groove Dimensions

RING NO.	HOUSING DIAMETER (mm)	GROOVE SIZE					RING SIZE						THRUST LOAD (N)			
		DIAMETER			WIDTH		DEPTH	FREE DIAMETER			THICKNESS		SECTION		RING Safety factor of 3	GROOVE Safety factor of 2
		Dg	Tol.		W	Tol.	d	Df	Tol.	T	Tol.	S	Tol.			
DKR-175	175	180,0	+0,63 -0,00	4,15		2,5	181,36	+1,40	3,89		7,92		589815	213221		
DKR-180	180	185,0	+0,72 -0,00	4,15	+0,18 -0,00	2,5	186,39	-0,00	3,89	±0,10	7,92	±0,15	606667	219313		
DKR-185	185	190,0		4,15		2,5	191,44	3,89	7,92		623519		225405			
DKR-190	190	195,0		4,15		2,5	196,47	3,89	7,92		640371		231497			
DKR-195	195	200,0		4,15		2,5	201,52	3,89	7,92		657223		237589			
DKR-200	200	205,0	+0,81 -0,00	4,15	+0,22 -0,00	2,5	206,58	+1,78 -0,00	3,89	±0,13	7,92	±0,19	674075	243681		
DKR-210	210	216,0		5,15		3,0	217,58		4,86		9,53		884268	307038		
DKR-220	220	226,0		5,15		3,0	227,66		4,86		9,53		926376	321659		
DKR-230	230	236,0		5,15		3,0	237,72		4,86		9,53		968484	336280		
DKR-240	240	246,0	+0,89 -0,00	5,15	+0,22 -0,00	3,0	247,80	+3,05 -0,00	4,86	±0,13	9,53	±0,19	1010592	350900		
DKR-250	250	256,0		5,15		4,0	257,89		4,86		11,18		1052700	365521		
DKR-260	260	268,0		5,15		4,0	269,93		4,86		11,18		1094808	506856		
DKR-270	270	278,0		5,15		4,0	280,01		4,86		11,18		1136916	526351		
DKR-280	280	288,0	+0,89 -0,00	5,15	+0,22 -0,00	4,0	290,09	+3,56 -0,00	4,86	±0,13	11,18	±0,19	1179024	545845		
DKR-290	290	298,0		5,15		4,0	300,15		4,86		11,18		1221132	565340		
DKR-300	300	308,0		5,15		4,0	310,24		4,86		11,18		1263241	584834		
DKR-310	310	320,0		6,20		5,0	322,25		5,87		12,70		1576625	755411		
DKR-320	320	330,0	+0,89 -0,00	6,20	+0,22 -0,00	5,0	332,33	+3,56 -0,00	5,87	±0,13	12,70	±0,19	1627484	779779		
DKR-330	330	340,0		6,20		5,0	342,42		5,87		12,70		1678342	804147		
DKR-340	340	350,0		6,20		5,0	352,50		5,87		12,70		1729201	828515		
DKR-350	350	360,0		6,20		5,0	362,56		5,87		12,70		1780060	852883		
DKR-360	360	370,0	+0,89 -0,00	6,20	+0,22 -0,00	5,0	372,64	+3,56 -0,00	5,87	±0,13	12,70	±0,19	1830919	877251		
DKR-370	370	380,0		6,20		5,0	382,73		5,87		12,70		1881778	901619		
DKR-380	380	390,0		6,20		5,0	392,79		5,87		12,70		1932637	925987		
DKR-390	390	400,0		6,20		5,0	402,84		5,87		12,70		1983496	950355		
DKR-400	400	410,0	6,20	5,0	412,93	5,87	12,70	2034354	974723							

DCR Spiral Shaft Rings

DIN 471

External, Heavy Duty DIN
 For applications where European DIN standards need to be met, these rings are designed to fit into the grooves established by DIN specifications.

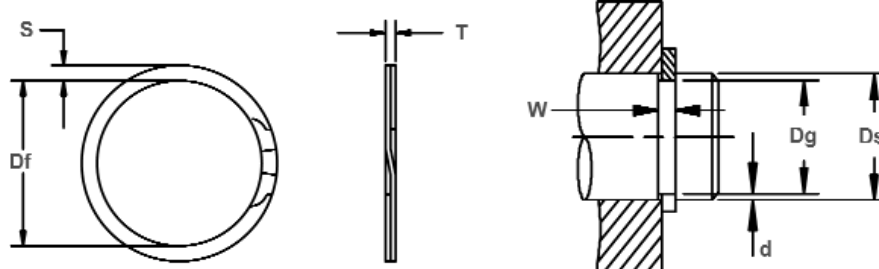

Free Diameter & Ring Measurements

Shaft Diameter & Groove Dimensions

RING NO.	SHAFT DIAMETER (mm)	GROOVE SIZE					RING SIZE						THRUST LOAD (N)		
		DIAMETER		WIDTH		DEPTH	FREE DIAMETER			THICKNESS		SECTION		RING Safety factor of 3	GROOVE Safety factor of 2
		Ds	Dg	Tol.	W	Tol.	d	Df	Tol.	T	Tol.	S	Tol.		
DCR-13	13	12.4		1.10		0.3	12.27		0.99		1.4		13474	1901	
DCR-14	14	13.4		1.10		0.3	13.26		0.99		1.4		14510	2047	
DCR-15	15	14.3	+0,00	1.10		0.4	14.15		0.99		1.4		15547	2559	
DCR-16	16	15.2	-0,11	1.10		0.4	15.04		0.99		1.65		16583	3119	
DCR-17	17	16.2		1.10		0.4	16.04		0.99		1.65		17620	3314	
DCR-18	18	17.0		1.30		0.5	16.83		1.14		1.91		18668	4386	
DCR-19	19	18.0		1.30		0.5	17.83	+0,00	1.14		1.91		19705	4630	
DCR-20	20	19.0		1.30		0.5	18.82	-0,33	1.14		1.91		20742	4874	
DCR-21	21	20.0	+0,00	1.30		0.5	19.79		1.14		1.91		21779	5117	
DCR-22	22	21.0	-0,13	1.30		0.5	20.78		1.14		1.91		22816	5361	
DCR-23	23	22.0		1.30		0.5	21.77		1.14		1.91		23853	5605	
DCR-24	24	22.9		1.30		0.6	22.66		1.14		2.18		24891	6433	
DCR-25	25	23.9		1.30		0.6	23.65		1.14		2.18		25928	6701	
DCR-26	26	24.9	+0,00	1.30		0.6	24.64		1.14		2.18		26965	6969	
DCR-27	27	25.6	-0,21	1.30		0.7	25.34		1.14	±0,05	2.18	±0,10	28002	9211	
DCR-28	28	26.6		1.60		0.7	26.34		1.44		2.39		36681	9552	
DCR-29	29	27.6		1.60		0.7	27.33		1.44		2.39		37991	9893	
DCR-30	30	28.6		1.60		0.7	28.32		1.44		2.39		39301	10235	
DCR-32	32	30.3		1.60		0.9	30.00	+0,00	1.44		3.25		41921	13256	
DCR-33	33	31.3		1.60	+0,14	0.9	30.99	-0,38	1.44		3.25		43231	13670	
DCR-34	34	32.3		1.60	-0,00	0.9	31.98		1.44		3.25		44541	14085	
DCR-35	35	33.0		1.60		1.0	32.66		1.44		3.25		45851	17058	
DCR-36	36	34.0		1.85		1.0	33.65		1.69		4.01		55349	17545	
DCR-38	38	36.0		1.85		1.0	35.64		1.69		4.01		58424	18520	
DCR-40	40	37.5	+0,00	1.85		1.3	37.11		1.69		4.01		61498	24368	
DCR-42	42	39.5	-0,25	1.85		1.3	39.09		1.69		4.01		64573	25586	
DCR-45	45	42.5		1.85		1.3	42.06	+0,00	1.69		4.01		69186	27414	
DCR-46	46	43.5		1.85		1.3	43.05	-0,51	1.69		4.01		70723	28023	
DCR-47	47	44.5		1.85		1.3	44.04		1.69		4.01		72261	28633	
DCR-48	48	45.5		1.85		1.3	45.03		1.69		4.01		73798	29242	
DCR-50	50	47.0		2.15		1.5	46.53		1.93		5.08		87790	36552	
DCR-52	52	49.0		2.15		1.5	48.51		1.93		5.08		91302	38014	
DCR-54	54	51.0		2.15		1.5	50.50		1.93		5.08		94813	39476	
DCR-55	55	52.0		2.15		1.5	51.49		1.93		5.08		96569	40207	
DCR-56	56	53.0		2.15		1.5	52.48	+0,00	1.93		5.08		98325	40938	
DCR-58	58	55.0		2.15		1.5	54.43	-0,63	1.93		5.08		101836	42400	
DCR-60	60	57.0		2.15		1.5	56.42		1.93		5.08		105348	43863	
DCR-62	62	59.0		2.15		1.5	58.42		1.93		5.08		108860	45325	
DCR-63	63	60.0		2.15		1.5	59.39		1.93		5.08	±0,12	110615	46056	
DCR-65	65	62.0	+0,00	2.65		1.5	61.39		2.41	±0,08	5.08		135725	47518	
DCR-67	67	64.0	-0,30	2.65		1.5	63.37		2.41		5.08		139901	48980	
DCR-68	68	65.0		2.65		1.5	64.34		2.41		5.08		141989	49711	
DCR-70	70	67.0		2.65		1.5	66.34		2.41		5.08		146165	51173	
DCR-72	72	69.0		2.65		1.5	68.33		2.41		5.08		150341	52635	
DCR-75	75	72.0		2.65		1.5	71.33	+0,00	2.41		5.08		156605	54828	
DCR-77	77	74.0		2.65		1.5	73.33	-0,76	2.41		5.08		160782	56290	
DCR-78	78	75.0		2.65		1.5	74.33		2.41		5.08		162870	57021	
DCR-80	80	76.5		2.65		1.8	75.81		2.41		6.05	±0,13	167046	68231	
DCR-82	82	78.5		2.65		1.8	77.81		2.41		6.05		171222	69936	

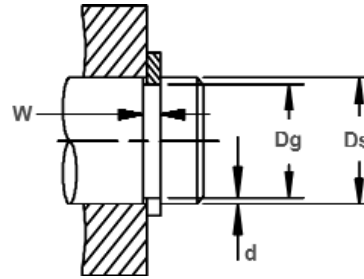
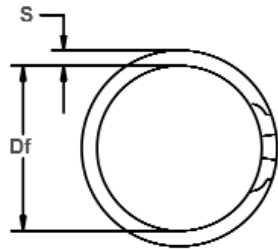

Free Diameter & Ring Measurements

Shaft Diameter & Groove Dimensions

RING NO.	SHAFT DIAMETER (mm)	GROOVE SIZE					RING SIZE						THRUST LOAD (N)		
		DIAMETER		WIDTH		DEPTH	FREE DIAMETER			THICKNESS		SECTION		RING Safety factor of 3	GROOVE Safety factor of 2
		Dg	Tol.	W	Tol.	d	Df	Tol.	T	Tol.	S	tol.			
DCR-85	85	81,5		3,15		1,8	80,80	+0,00'-0,76	2,91		6,35		214309	72495	
DCR-88	88	84,5		3,15		1,8	83,80		2,91		6,35		221873	75054	
DCR-90	90	86,5	+0,00	3,15		1,8	85,80	+0,00	2,91	±0,08	6,35		226915	76759	
DCR-95	95	91,5	-0,35	3,15		1,8	90,80	-0,89	2,91		6,35		239522	81024	
DCR-98	98	94,5		3,15		1,8	93,79		2,91		6,35		247086	83583	
DCR-100	100	96,5		3,15		1,8	95,79		2,91		6,35		252128	85288	
DCR-102	102	98,0		4,15		2,0	97,29		3,89		6,73		343778	99422	
DCR-105	105	101,0		4,15		2,0	100,28		3,89		6,73	±0,13	353889	102346	
DCR-108	108	104,0	+0,00	4,15		2,0	103,25		3,89		6,73		364000	105270	
DCR-110	110	106,0	-0,54	4,15		2,0	105,23		3,89		6,73		370741	107220	
DCR-115	115	111,0		4,15		2,0	110,19		3,89		6,73		387593	112093	
DCR-120	120	116,0		4,15		2,0	115,16	+0,00	3,89		6,73		404445	116967	
DCR-125	125	121,0		4,15		2,0	120,12	-1,30	3,89		6,73		421297	121840	
DCR-130	130	126,0		4,15		2,0	125,07		3,89		6,73		438149	126714	
DCR-135	135	131,0		4,15		2,0	130,02		3,89		6,73		455001	131588	
DCR-140	140	136,0		4,15		2,0	134,98		3,89		6,73		471852	136461	
DCR-145	145	141,0		4,15		2,0	139,93		3,89	±0,10	6,73		488704	141335	
DCR-150	150	145,0	+0,00	4,15	+0,18	2,5	143,91		3,89		7,92		505556	182761	
DCR-155	155	150,0	-0,63	4,15	-0,00	2,5	148,89		3,89		7,92		522408	188853	
DCR-160	160	155,0		4,15		2,5	153,85		3,89		7,92		539260	194945	
DCR-165	165	160,0		4,15		2,5	158,80	+0,00	3,89		7,92		556112	201037	
DCR-170	170	165,0		4,15		2,5	163,75	-1,52	3,89		7,92		572964	207129	
DCR-175	175	170,0		4,15		2,5	168,73		3,89		7,92		589815	213221	
DCR-180	180	175,0		4,15		2,5	173,69		3,89		7,92		606667	219313	
DCR-185	185	180,0		4,15		2,5	178,66		3,89		7,92	±0,15	623519	225405	
DCR-190	190	185,0		4,15		2,5	183,59		3,89		7,92		640371	231497	
DCR-195	195	190,0		4,15		2,5	188,54		3,89		7,92		657223	237589	
DCR-200	200	195,0		4,15		2,5	193,54		3,89		7,92		674075	243681	
DCR-205	205	199,0	+0,00	5,15		3,0	197,54	+0,00	4,86		11,18		863214	299727	
DCR-210	210	204,0	-0,72	5,15		3,0	202,54	-1,78	4,86		11,18		884268	307038	
DCR-220	220	214,0		5,15		3,0	212,47		4,86		11,18		926376	321659	
DCR-230	230	224,0		5,15		3,0	222,40		4,86		11,18		968484	336280	
DCR-240	240	234,0		5,15		3,0	232,33		4,86		11,18		1010592	350900	
DCR-250	250	244,0		5,15		3,0	242,24		4,86		11,18		1052700	365521	
DCR-260	260	252,0		5,15		4,0	250,19		4,86		12,70		1094808	506856	
DCR-270	270	262,0		5,15		4,0	260,15	+0,00	4,86		12,70		1136916	526351	
DCR-280	280	272,0	+0,00	5,15		4,0	270,08	-2,30	4,86		12,70		1179024	545845	
DCR-290	290	282,0	-0,81	5,15		4,0	279,98		4,86	±0,13	12,70		1221132	565340	
DCR-300	300	292,0		5,15		4,0	289,92		4,86		12,70		1263241	584834	
DCR-310	310	300,0		6,20		5,0	297,84		5,87		15,88		576625	755411	
DCR-320	320	310,0		6,20		5,0	307,84		5,87		15,88		627484	779779	
DCR-330	330	320,0		6,20		5,0	317,75		5,87		15,88	±0,19	1678342	804147	
DCR-340	340	330,0		6,20		5,0	327,69		5,87		15,88		729201	828515	
DCR-350	350	340,0	+0,00	6,20	+0,22	5,0	337,64	+0,00	5,87		15,88		1780060	852883	
DCR-360	360	350,0	-0,89	6,20	-0,00	5,0	347,57	-2,80	5,87		15,88		1830919	877251	
DCR-370	370	360,0		6,20		5,0	357,48		5,87		15,88		1881778	901619	
DCR-380	380	370,0		6,20		5,0	367,41		5,87		15,88		1932637	925987	
DCR-390	390	380,0		6,20		5,0	377,34		5,87		15,88		1983496	950355	
DCR-400	400	390,0		6,20		5,0	387,25		5,87		15,88		2034354	974723	



DKL Spiral Housing Rings

Internal, Light Duty, Metric

These single-turn retaining rings are ideal for light-duty applications, or where axial positioning is the primary function.

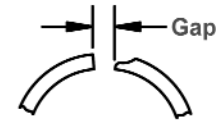
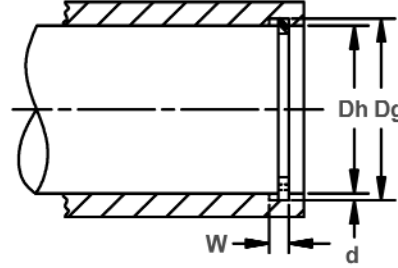
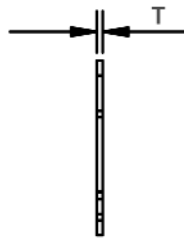
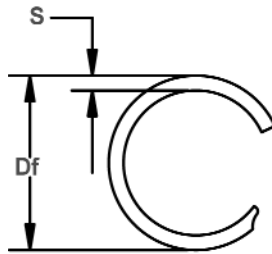

Optional End Designs

Free Diameter & Ring Measurements

Housing Diameter & Groove Dimensions

RING NO.	HOUSING DIAMETER (mm)	GROOVE SIZE				RING SIZE				THRUST LOAD (N)			
		DIAMETER		WIDTH		FREE DIAMETER		THICKNESS		SECTION		RING Safety factor of 3	GROOVE Safety factor of 2
		Dh	Dg	Tol.	W	Tol.	Df	Tol.	T	Tol.	S		
DKL-13	13	13,60		1,10		13,73		0,94		1,40		10591	1931
DKL-14	14	14,60	+0,11	1,10		14,74		0,94		1,40		11396	2077
DKL-15	15	15,70	-0,00	1,10		15,85		0,94		1,40		12224	2602
DKL-16	16	16,80		1,10		16,90		0,94		1,65		13029	3172
DKL-17	17	17,80		1,10		17,97	+0,33	0,94		1,65		13838	3367
DKL-18	18	19,00		1,10		19,18	-0,00	0,94		1,90		14666	4457
DKL-19	19	20,00	+0,13	1,10		20,25		0,94		1,90		15471	5702
DKL-20	20	21,00	-0,00	1,10		21,20		0,94		1,90		16276	4951
DKL-21	21	22,00		1,10		22,21		0,94		1,90		17103	5200
DKL-22	22	23,00		1,10		23,22		0,94		1,90		17913	5445
DKL-23	23	24,00		1,10		24,23		0,94		1,90		18736	5698
DKL-24	24	25,20	+0,21	1,30		25,40		1,15		2,15		23927	6539
DKL-25	25	26,20	-0,00	1,30		26,45		1,15	±0,05	2,15	±0,10	24914	6806
DKL-26	26	27,20		1,30		27,46		1,15		2,15		25929	7082
DKL-27	27	28,20		1,30		28,47		1,15		2,38		26916	7353
DKL-28	28	29,40		1,30		29,68		1,15		2,38		27904	9702
DKL-29	29	30,40		1,30		30,69	+0,38	1,15		2,38		28918	10053
DKL-30	30	31,40		1,30		31,79	-0,00	1,15		2,38		29905	10395
DKL-31	31	32,70		1,30		33,01		1,15		2,38		30893	12660
DKL-32	32	33,70		1,30		33,93		1,15		2,38		31907	13073
DKL-33	33	34,70		1,30	+0,14	35,03		1,15		2,38		32895	13478
DKL-34	34	35,70		1,60	-0,00	36,04		1,44		3,25		40319	13892
DKL-35	35	37,00	+0,25	1,60		37,35		1,44		3,25		41493	16899
DKL-36	36	38,00	-0,00	1,60		38,36		1,44		3,25		42663	17375
DKL-37	37	39,00		1,60		39,37		1,44		3,25		43868	17869
DKL-38	38	40,00		1,60		40,44		1,44		3,25		45043	18344
DKL-40	40	42,50		1,85		42,86		1,69		4,01		55621	24265
DKL-41	41	43,50		1,85		43,91		1,69		4,01		56995	24866
DKL-42	42	44,50		1,85		44,92	+0,51	1,69		4,01		58410	25484
DKL-45	45	47,50		1,85		47,88	-0,00	1,69		4,01		62578	27303
DKL-47	47	49,50		1,85		49,97		1,69		4,01		65331	28504
DKL-48	48	50,50		1,85		50,98		1,69		4,01		66741	29118
DKL-50	50	53,00		2,15		53,50		1,93		5,08		75282	36529
DKL-51	51	54,00		2,15		54,43		1,93		5,08		76776	37249
DKL-52	52	55,00		2,15		55,52		1,93		5,08		78266	37974
DKL-55	55	58,00		2,15		58,55		1,93		5,08		82777	40163
DKL-56	56	59,00		2,15		59,56	+0,63	1,93		5,08		84307	40906
DKL-57	57	60,00	+0,30	2,15		60,68	-0,00	1,93		5,08		85797	41631
DKL-58	58	61,00	-0,00	2,15		61,58		1,93	±0,08	5,08	±0,13	87287	42352
DKL-60	60	63,00		2,15		63,60		1,93		5,08		90308	43819
DKL-62	62	65,00		2,15		65,58		1,93		5,08		93328	45283
DKL-63	63	66,00		2,15		66,63		1,93		5,08		94823	46008
DKL-64	64	67,00		2,65		67,64		2,41		5,08		114742	46751
DKL-65	65	68,00		2,65		68,70		2,41		5,08		116517	47471
DKL-67	67	70,00		2,65		70,54	+0,76	2,41		5,08		120115	48939
DKL-68	68	71,00		2,65		71,84	-0,00	2,41		5,08		121890	49660
DKL-70	70	73,00		2,65		73,64		2,41		5,08		125489	51128



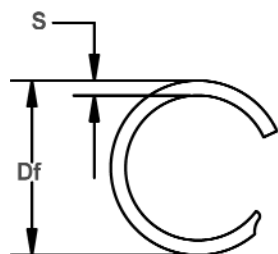

Free Diameter & Ring Measurements

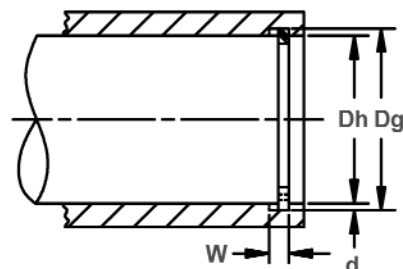
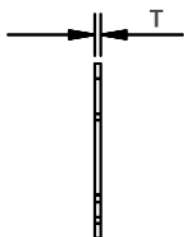

Housing Diameter & Groove Dimensions

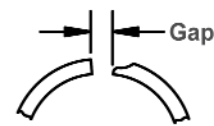

Optional End Designs

RING NO.	HOUSING DIAMETER (mm)	GROOVE SIZE				RING SIZE						THRUST LOAD (N)		
		DIAMETER		WIDTH		FREE DIAMETER		THICKNESS		SECTION		RING Safety factor of 3	GROOVE Safety factor of 2	
		Dh	Dg	Tol.	W	Tol.	Df	Tol.	T	Tol.	S			Tol.
DKL-72	72	75.00	+0,30	2,65	+0,14	-0,00	75,72	+0,76	2,41	±0,08	5,08	±0,13	129083	52591
DKL-75	75	78,00	-0,00	2,65			78,75		2,41		5,08		134456	54780
DKL-76	76	79,00	+0,35	2,65			79,88		2,41		5,08		136231	55505
DKL-78	78	81,00		-0,00	2,65	81,73	2,41	5,08	139830		56968			
DKL-80	80	83,50	-0,00	2,65	+0,89	-0,00	84,30	2,41	6,02		143428		68342	
DKL-82	82	85,50		86,32			2,41	6,02	146978		70033			
DKL-85	85	88,50		3,15			89,35	2,91	6,30		175046		72595	
DKL-88	88	91,50		3,15			92,38	2,91	6,30		181269		75175	
DKL-90	90	93,50	+0,54	3,15	-0,00	94,70	2,91	6,30	185353		76865			
DKL-92	92	95,50		3,15		96,50	2,91	6,30	189485		78582			
DKL-95	95	98,50		3,15		99,62	2,91	6,30	195659	81140				
DKL-98	98	101,50		3,15		102,71	2,91	6,30	201829	83702				
DKL-100	100	103,50		3,15		104,50	2,91	6,30	205962	85415				
DKL-102	102	106,00		4,15		107,27	3,89	6,73	269224	87127				
DKL-105	105	109,00		4,15		109,96	3,89	6,73	277133	102687				
DKL-108	108	112,00		4,15		113,09	3,89	6,73	285042	105619				
DKL-110	110	114,00	+0,63	4,15	+0,18	-0,00	115,10	3,89	6,73	290340	107580			
DKL-112	112	116,00		4,15			117,12	3,89	6,73	295567	109520			
DKL-115	115	119,00		4,15			120,15	+1,30	6,73	303547	112473			
DKL-120	120	124,00		-0,00			4,15	-0,00	125,60	3,89	6,73	316678	117344	
DKL-125	125	129,00					4,15		130,25	3,89	6,73	329893	122237	
DKL-127	127	131,00		+0,72			4,15	-0,00	132,27	3,89	6,73	335187	124199	
DKL-130	130	134,00					4,15		135,30	3,89	6,73	343096	127130	
DKL-135	135	139,00	4,15		140,35	3,89	6,73		356303	132023				
DKL-140	140	144,00	4,15		145,26	3,89	6,73		369509	136916				
DKL-145	145	149,00	-0,00	4,15	+1,40	-0,00	150,45	3,89	6,73	382716	141809			
DKL-150	150	155,00		4,15			156,50	3,89	8,03	395923	181986			
DKL-155	155	160,00		4,15			161,55	3,89	8,03	409063	188026			
DKL-160	160	165,00	+0,81	4,15	+0,15	-0,00	166,60	3,89	8,03	422270	194094			
DKL-165	165	170,00		4,15			171,70	3,89	8,03	435476	200166			
DKL-170	170	175,00		4,15			176,70	3,89	8,03	448683	206237			
DKL-175	175	180,00		4,15			181,75	3,89	8,03	461890	212305			
DKL-180	180	185,00		+0,72			4,15	-0,00	186,80	3,89	8,03	475097	218377	
DKL-185	185	190,00					4,15		191,85	3,89	8,03	488232	224417	
DKL-190	190	195,00		-0,00			4,15	+1,78	-0,00	197,15	3,89	8,03	501439	230489
DKL-195	195	200,00					4,15			201,95	3,89	8,03	514646	236556
DKL-200	200	205,00	4,15		207,00	3,89	8,03			527853	242628			
DKL-210	210	216,00	+0,81	5,15	-0,00	217,93	4,87	9,48	657096	306763				
DKL-220	220	226,00		5,15		228,20	4,87	9,48	688327	321344				
DKL-230	230	236,00		5,15		238,30	4,87	9,48	719638	335961				
DKL-240	240	246,00		5,15		248,40	4,87	9,48	750953	350578				
DKL-250	250	256,00		5,15		258,50	4,87	9,48	782264	365199				
DKL-260	260	268,00		-0,00		5,15	+3,05	-0,00	270,77	4,87	11,05	813500	505300	
DKL-270	270	278,00				5,15			280,70	4,87	11,05	844811	524748	
DKL-280	280	288,00				5,15			290,57	4,87	11,05	876126	544200	
DKL-290	290	298,00				5,15			300,90	4,87	11,05	907357	563599	
DKL-300	300	308,00				5,15			311,00	4,87	11,05	938673	583051	



C DCL Spiral Shaft Rings

External, Light Duty, Metric

These single-turn retaining rings are ideal for light-duty applications, or where axial positioning is the primary function.

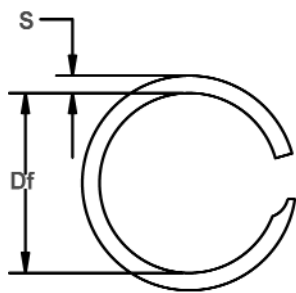

Free Diameter & Ring Measurements

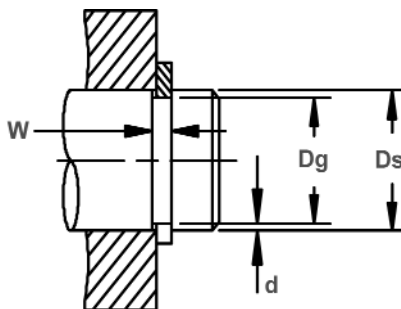

Shaft Diameter & Groove Dimensions

Optional End Designs

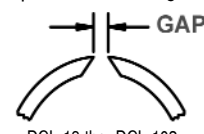

DCL-13 thru DCL-102

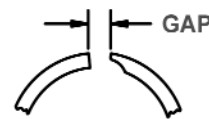

DCL-105 thru DCL-300

RING NO.	SHAFT DIAMETER (mm)	GROOVE SIZE				RING SIZE						THRUST LOAD (N)	
		DIAMETER		WIDTH		FREE DIAMETER		THICKNESS		SECTION		RING Safety factor of 3	GROOVE Safety factor of 2
		Dg	Tol.	W	Tol.	Df	Tol.	T	Tol.	S	Tol.		
DCL-13	13	12,4		1,10		12,27		0,94		1,40		10591	1931
DCL-14	14	13,4		1,10		13,31		0,94		1,40		11396	2077
DCL-15	15	14,3	+0,00	1,10		14,15		0,94		1,40		12224	2602
DCL-16	16	15,2	-0,11	1,10		14,98		0,94		1,65		13029	3172
DCL-17	17	16,2		1,10		16,06		0,94		1,65		13838	3367
DCL-18	18	17,0		1,30		16,82		1,15		1,90		17953	4457
DCL-19	19	18,0		1,30		17,81	+0,00	1,15		1,90		18941	4702
DCL-20	20	19,0		1,30		18,80	-0,33	1,15		1,90		19928	4951
DCL-21	21	20,0	+0,00	1,30		19,79		1,15		1,90		20942	5200
DCL-22	22	21,0	-0,13	1,30		20,83		1,15		1,90		21930	5445
DCL-23	23	22,0		1,30		21,77		1,15		1,90		22939	5698
DCL-24	24	22,9		1,30		22,50		1,15		2,15		23927	6539
DCL-25	25	23,9		1,30		23,70		1,15		2,15		24914	6806
DCL-26	26	24,9	+0,00	1,30		24,64		1,15	±0,05	2,15	±0,10	25929	7082
DCL-27	27	25,9	-0,21	1,30		25,50		1,15		2,15		26916	7353
DCL-28	28	26,6		1,60		26,32		1,44		3,25		33179	9702
DCL-29	29	27,6		1,60		27,15		1,44		3,25		34385	10053
DCL-30	30	28,6		1,60	+0,14	28,35		1,44		3,25		35559	10395
DCL-32	32	30,3		1,60	-0,00	29,87	+0,00	1,44		3,25		37939	13073
DCL-33	33	31,3		1,60		31,07	-0,38	1,44		3,25		39113	13478
DCL-34	34	32,3		1,60		31,96		1,44		3,25		40319	13892
DCL-35	35	33,0		1,60		32,57		1,44		3,25		41493	16899
DCL-36	36	34,0		1,85		33,64		1,69		4,01		50038	17375
DCL-38	38	36,0	+0,00	1,85		35,62		1,69		4,01		52827	18344
DCL-40	40	37,5	-0,25	1,85		37,02		1,69		4,01		55621	24265
DCL-42	42	39,5		1,85		39,08		1,69		4,01		58410	25484
DCL-45	45	42,5		1,85		42,05	+0,00	1,69		4,01		62578	27303
DCL-46	46	43,5		1,85		43,10	-0,51	1,69		4,01		63952	27904
DCL-47	47	44,5		1,85		44,03		1,69		4,01		65331	28504
DCL-48	48	45,5		1,85		44,89		1,69		4,01		66741	29118
DCL-50	50	47,0		2,15		46,50		1,93		5,08		75282	36529
DCL-52	52	49,0		2,15		48,48		1,93		5,08		78266	37974
DCL-54	54	51,0		2,15		50,46		1,93		5,08		81287	39438
DCL-55	55	52,0		2,15		51,45		1,93		5,08		82777	40163
DCL-56	56	53,0		2,15		52,44	+0,00	1,93		5,08		84307	40906
DCL-58	58	55,0		2,15		54,42	-0,63	1,93		5,08		87287	42352
DCL-60	60	57,0		2,15		56,55		1,93		5,08		90308	43819
DCL-62	62	59,0	+0,00	2,15		58,32		1,93	±0,08	5,08	±0,13	93328	45283
DCL-63	63	60,0	-0,30	2,15		59,37		1,93		5,08		94823	46008
DCL-65	65	62,0		2,65		61,35		2,41		5,08		116641	47471
DCL-67	67	64,0		2,65		63,35		2,41		5,08		120240	48939
DCL-68	68	65,0		2,65		64,45	+0,00	2,41		5,08		122019	49660
DCL-70	70	67,0		2,65		66,22	-0,76	2,41		5,08		125618	51128
DCL-72	72	69,0		2,65		68,62		2,41		5,08		129221	52591

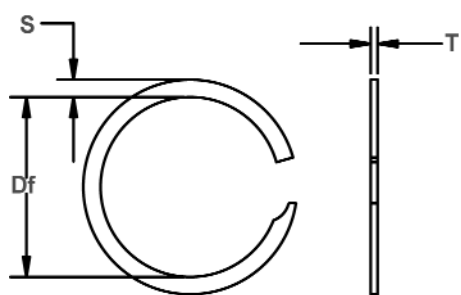

Free Diameter & Ring Measurements

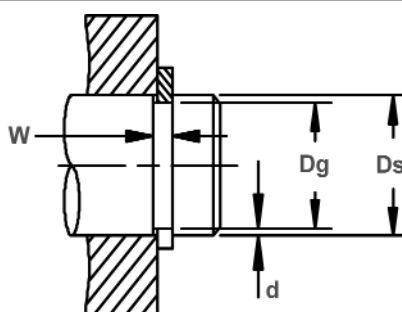

Shaft Diameter & Groove Dimensions

Optional End Designs

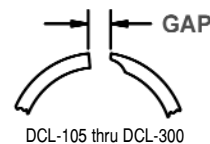
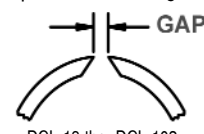

RING NO.	SHAFT DIAMETER (mm)	GROOVE SIZE				RING SIZE						THRUST LOAD (N)	
		DIAMETER		WIDTH		FREE DIAMETER		THICKNESS		SECTION		RING Safety factor of 3	GROOVE Safety factor of 2
		Dg	Tol.	W	Tol.	Df	Tol.	T	Tol.	S	Tol.		
DCL-75	75	72.0		2.65		71.25		2.41		5.08		134599	54780
DCL-77	77	74.0	+0,00	2.65	+0,14	73.23		2.41		5.08		138153	56230
DCL-78	78	75.0	-0,30	2.65	-0,00	74.06	+0,00	2.41		5.08		139977	56968
DCL-80	80	76.50		2.65		75.70	-0,76	2.41		6.02		143575	68342
DCL-82	82	78.50		2.65		77.68		2.41		6.02		147134	70033
DCL-85	85	81.50		3.15		80.65		2.91	±0,08	6.30		175656	72595
DCL-88	88	84.50		3.15		83.60		2.91		6.30		181906	75175
DCL-90	90	86.50	+0,00	3.15		85.80	+0,00	2.91		6.30		185998	76865
DCL-95	95	91.50	-0,35	3.15		90.68	-0,89	2.91		6.30		196340	81140
DCL-98	98	94.50		3.15		93.70		2.91		6.30		202536	83702
DCL-100	100	96.50		3.15		95.50		2.91		6.30		206682	85415
DCL-102	102	98.50		3.15		97.23		2.91		6.30	±0,13	210828	87127
DCL-105	105	100.00		4.15		99.83		3.89		6.73		276951	102687
DCL-108	108	104.00	+0,00	4.15		102.87		3.89		6.73		284855	105619
DCL-110	110	106.00	-0,54	4.15		104.90		3.89		6.73		290149	107580
DCL-115	115	111.00		4.15		109.85	+0,00	3.89		6.73		303346	112473
DCL-120	120	116.00		4.15		115.06	-1,30	3.89		6.73		316478	117344
DCL-125	125	121.00		4.15		119.75		3.89		6.73		329676	122237
DCL-130	130	126.00		4.15		124.70		3.89		6.73		342873	127130
DCL-135	135	131.00		4.15		129.65		3.89		6.73		356071	132023
DCL-140	140	136.00		4.15		134.42		3.89		6.73		369269	136916
DCL-145	145	141.00		4.15		139.55		3.89	±0,10	6.73		382467	141809
DCL-150	150	145.00	+0,00	4.15	+0,18	143.50		3.89		8.03		395665	181986
DCL-155	155	150.00	-0,63	4.15	-0,00	148.45		3.89		8.03		408796	188026
DCL-160	160	155.00		4.15		153.40	+0,00	3.89		8.03		421994	194094
DCL-165	165	160.00		4.15		158.40	-1,52	3.89		8.03		435192	200166
DCL-170	170	165.00		4.15		163.30		3.89		8.03		448683	206237
DCL-175	175	170.00		4.15		168.25		3.89		8.03	±0,15	461890	212305
DCL-180	180	175.00		4.15		173.20		3.89		8.03		475097	218377
DCL-185	185	180.00		4.15		177.62		3.89		8.03		488232	224417
DCL-190	190	185.00		4.15		183.35		3.89		8.03		501439	230489
DCL-195	195	190.00		4.15		188.05		3.89		8.03		514646	236556
DCL-200	200	195.00		4.15		193.00	+0,00	3.89		8.03		527853	242628
DCL-205	205	199.00	+0,00	5.15		196.95	-1,78	4.87		11,05		641438	299454
DCL-210	210	204.00	-0,72	5.15		201.67		4.87		11,05		657096	306763
DCL-220	220	214.00		5.15		211.80		4.87		11,05		688327	321344
DCL-230	230	224.00		5.15		221.70		4.87		11,05		719638	335961
DCL-240	240	234.00		5.15		231.89		4.87		11,05		750953	350578
DCL-250	250	244.00		5.15		241.50		4.87	±0,13	11,05	±0,18	782264	365199
DCL-260	260	252.00		5.15		249.59		4.87		12,70		813500	505300
DCL-270	270	262.00	+0,00	5.15		259.30	+0,00	4.87		12,70		844811	524748
DCL-280	280	272.00	-0,81	5.15		268.83	-2,30	4.87		12,70		876126	544200
DCL-290	290	282.00		5.15		279.10		4.87		12,70		907357	563599
DCL-300	300	292.00		5.15		289.00		4.87		12,70		938673	583051

KLM Spiral Housing Rings

Internal, Light-Duty, Metric

These single-turn retaining rings are ideal for light-duty applications, or where axial positioning is the primary function.

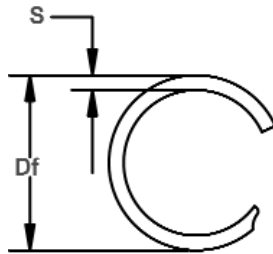

Free Diameter & Ring Measurements

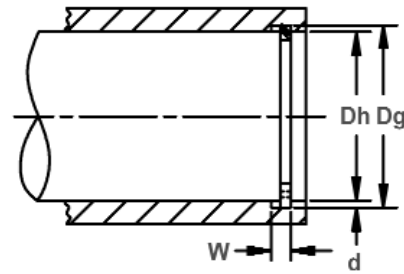
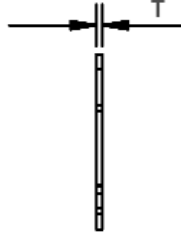

Housing Diameter & Groove Dimensions

RING NO.	HOUSING DIAMETER (mm)	GROOVE SIZE				RING SIZE						THRUST LOAD (N)	
		DIAMETER		WIDTH		FREE DIAMETER		THICKNESS		SECTION		RING Safety factor of 3	GROOVE Safety factor of 2
		Dh	Dg	Tol.	W	Tol.	Df	Tol.	T	Tol.	S		
KLM-6*	6	6.30		0.38		6.35		0.30		0.51		1.99	0.44
KLM-7*	7	7.32		0.38		7.38	+0.25	0.30		0.51		2.32	0.55
KLM-8*	8	8.36		0.46		8.44	-0.00	0.38		0.64		3.18	0.70
KLM-9*	9	9.46		0.46		9.54		0.38		0.76		3.58	1.00
KLM-10*	10	10.50		0.46		10.58	+0.30	0.38		0.76		3.98	1.24
KLM-11	11	11.60		0.46		11.68	-0.00	0.38		0.89		4.39	1.63
KLM-12	12	12.66	+0.05	0.46		12.74		0.38		0.89		4.77	1.93
KLM-13	13	13.72		0.56		13.80		0.46		1.14		6.26	2.28
KLM-14	14	14.72		0.56		14.80		0.46		1.14		6.74	2.46
KLM-15	15	15.72		0.56		15.80		0.46		1.14		7.22	2.63
KLM-16	16	16.72		0.56		16.80		0.46		1.14		7.71	2.81
KLM-17	17	17.72		0.56	+0.05	17.82		0.46	+0.04	1.14		8.19	2.98
KLM-18	18	18.72		0.56	-0.00	18.82	+0.33	0.46		1.14		8.67	3.16
KLM-19	19	19.76		0.56		19.86	-0.00	0.46		1.14		9.15	3.52
KLM-20	20	21.06		0.66		21.26		0.53		1.65		11.10	5.17
KLM-21	21	22.06	+0.08	0.66		22.27		0.53		1.65		11.65	5.42
KLM-22	22	23.06		0.66		23.28		0.53		1.65		12.21	5.68
KLM-24	24	25.06		0.66		25.29		0.53		1.65		13.32	6.20
KLM-25	25	26.06		0.66		26.30		0.53		1.65		13.87	6.46
KLM-26	26	27.06		0.66		27.31		0.53		1.65	+0.10	14.43	6.72
KLM-28	28	29.12		0.79		29.40		0.64		2.24		16.30	7.64
KLM-29	29	30.12		0.79		30.41		0.64		2.24		16.88	7.91
KLM-30	30	31.12		0.79		31.42		0.64		2.24		17.47	8.19
KLM-31	31	32.12	+0.10	0.79		32.43	+0.38	0.64		2.24		18.05	8.46
KLM-32	32	33.12		0.79		33.44	-0.00	0.64		2.24		18.63	8.73
KLM-34	34	35.12		0.79		35.45		0.64		2.24		19.80	9.28
KLM-35	35	36.12		0.79		36.47		0.64		2.24		20.38	9.55
KLM-36	36	37.12		0.79		37.48		0.64		2.24		20.96	9.83
KLM-37	37	38.12		0.79		38.49		0.64		2.24		21.54	10.10
KLM-38	38	39.12		0.79		39.50		0.64		2.24		22.12	10.37
KLM-40	40	41.48		0.99		41.94		0.79		3.00		28.75	14.43
KLM-42	42	43.48		0.99		43.96		0.79		3.00		30.19	15.15
KLM-45	45	46.48	+0.13	0.99		46.99	+0.51	0.79		3.00		32.34	16.23
KLM-47	47	48.48		0.99		49.00	-0.00	0.79		3.00		33.78	16.95
KLM-48	48	49.48		0.99		50.01		0.79		3.00		34.50	17.31
KLM-50	50	51.48		0.99	+0.08	52.04		0.79		3.00		35.93	18.03
KLM-52	52	53.94		0.99	-0.00	54.55		0.79	+0.05	4.01		37.37	24.58
KLM-55	55	56.94		0.99		57.57		0.79		4.01		39.53	26.00
KLM-56	56	57.94		0.99		58.58		0.79		4.01		40.25	26.47
KLM-58	58	59.94		0.99		60.60	+0.64	0.79		4.01		41.68	27.42
KLM-60	60	61.94	+0.15	0.99		62.64	-0.00	0.79		4.01		43.12	28.36
KLM-62	62	63.94		0.99		64.67		0.79		4.01		44.56	29.31
KLM-63	63	64.94		0.99		65.69		0.79		4.01		45.28	29.78
KLM-65	65	66.94		0.99		67.70		0.79		4.01		46.72	30.73

* No Removal Notch.

ALL DIMENSIONS IN MILLIMETERS UNLESS OTHERWISE STATED.

CLM Spiral Shaft Rings

External, Light-Duty, Metric

These single-turn retaining rings are ideal for light-duty applications, or where axial positioning is the primary function.

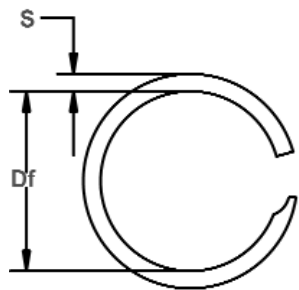

Free Diameter & Ring Measurements

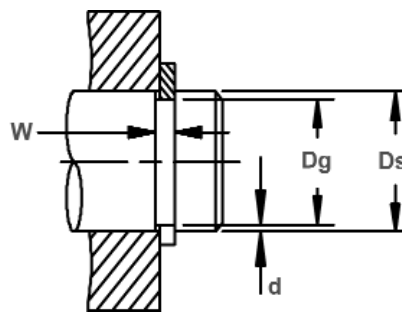
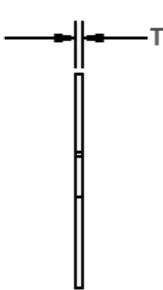

Shaft Diameter & Groove Dimensions

RING NO.	SHAFT DIAMETER (mm)	GROOVE SIZE				FREE DIAMETER		RING SIZE			THRUST LOAD (N)		
		DIAMETER		WIDTH				THICKNESS		SECTION		RING Safety factor of 3	GROOVE Safety factor of 2
		Ds	Dg	Tol.	W	Tol.	Df	Tol.	T	Tol.	S		
CLM-6*	6	5.70	±0.05	0.38	+0.05 -0.00	5.65	+0.00 -0.25	0.30	±0.04	0.51	±0.10	1.99	0.44
CLM-7*	7	6.64		0.38		6.58		0.30		0.51		2.23	0.61
CLM-8*	8	7.60		0.46		7.52		0.38		0.64		3.18	0.78
CLM-9*	9	8.50		0.46		8.42		0.38		0.76		3.58	1.11
CLM-10*	10	9.40		0.46		9.32		+0.30		0.89		3.98	1.46
CLM-11	11	10.40		0.46		10.32		-0.25		0.38		4.38	1.61
CLM-12	12	11.34		0.56		11.22		0.46		1.14		5.78	1.93
CLM-13	13	12.28		0.56		12.15		0.46		1.14		6.26	2.28
CLM-14	14	13.28		0.56		13.15		0.46		1.14		6.74	2.46
CLM-15	15	14.28		0.56		14.14		0.46		1.14		7.22	2.63
CLM-16	16	15.28		0.56		15.13		0.46		1.14		7.71	2.81
CLM-17	17	16.28	0.56	16.13	+0.00	0.46	8.19	2.98					
CLM-18	18	17.28	0.56	17.12	-0.33	0.46	8.67	3.16					
CLM-19	19	18.28	0.56	18.11	0.46	1.14	9.15	3.33					
CLM-20	20	19.28	0.56	19.10	0.46	1.14	9.63	3.51					
CLM-21	21	19.94	±0.08	0.66	19.74	0.53	11.65	5.42					
CLM-22	22	20.94		0.66	20.73	0.53	1.65	12.21	5.68				
CLM-24	24	22.94		0.66	22.72	0.53	1.65	13.32	6.20				
CLM-25	25	23.94		0.66	23.71	0.53	1.65	13.87	6.46				
CLM-26	26	24.88		0.79	24.63	0.64	2.24	15.14	7.10				
CLM-28	28	26.88	±0.10	0.79	26.62	0.64	16.30	7.64					
CLM-29	29	27.88		0.79	27.61	0.64	2.24	16.88	7.91				
CLM-30	30	28.88		0.79	28.59	+0.00	0.64	17.47	8.19				
CLM-32	32	30.88		0.79	30.57	-0.38	0.64	18.63	8.73				
CLM-34	34	32.88		0.79	32.56	0.64	2.24	19.80	9.28				
CLM-35	35	33.88		0.79	33.55	0.64	2.24	20.38	9.55				
CLM-36	36	34.88		0.79	34.54	0.64	2.24	20.96	9.83				
CLM-38	38	36.88	0.79	36.52	0.64	2.24	22.12	10.37					
CLM-40	40	38.52	±0.13	0.99	38.09	0.79	28.75	14.43					
CLM-42	42	40.52		0.99	40.07	+0.00	0.79	30.19	15.15				
CLM-45	45	43.52		0.99	43.04	-0.51	0.79	32.34	16.23				
CLM-48	48	46.52	±0.15	0.99	46.01	0.79	34.50	17.31					
CLM-50	50	48.52		0.99	47.99	0.79	3.00	35.93	18.03				
CLM-52	52	50.06		0.99	49.48	0.79	4.01	37.37	24.58				
CLM-55	55	53.06		0.99	52.46	0.79	4.01	39.53	26.00				
CLM-56	56	54.06		0.99	53.44	0.79	4.01	40.25	26.47				
CLM-58	58	56.06		0.99	55.42	+0.00	0.79	41.68	27.42				
CLM-60	60	58.06		0.99	57.40	-0.64	0.79	43.12	28.36				
CLM-62	62	60.06		0.99	59.37	0.79	4.01	44.56	29.31				
CLM-63	63	61.06		0.99	60.35	0.79	4.01	45.28	29.78				
CLM-65	65	63.06	0.99	62.33	0.79	4.01	46.72	30.73					

* No Removal Notch.

ALL DIMENSIONS IN MILLIMETERS UNLESS OTHERWISE STATED.



MKM Spiral Housing Rings

Internal, Medium Duty, Metric

These rings offer the greatest economy in price and size.

They are able to handle approximately twice the thrust capacity of the DKL series.

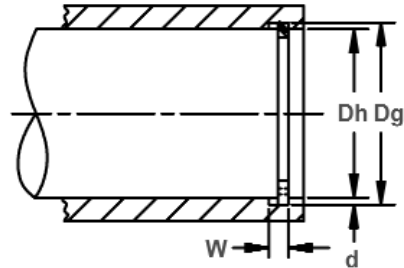
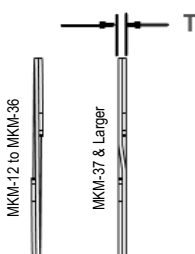
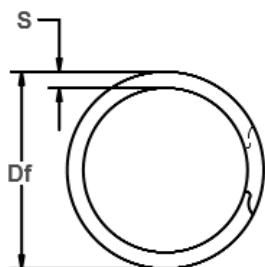

Free Diameter & Ring Measurements

Housing Diameter & Groove Dimensions

RING NO.	HOUSING DIAMETER (mm)	GROOVE SIZE				RING SIZE			THRUST LOAD (N)				
		DIAMETER		WIDTH		FREE DIAMETER		THICKNESS		SECTION	RING Safety factor of 3	GROOVE Safety factor of 2	
		Dh	Dg	Tol.	W	Tol.	Df	Tol.	T	Tol.	S	Tol.	
MKM-12	12	12.66		0.75		12.78		0.64		1.14		8484	1591
MKM-13	13	13.72		0.75		13.84		0.64		1.14		9191	2008
MKM-14	14	14.72	+0.00	0.75		14.85		0.64		1.14		9898	2311
MKM-15	15	15.72	-0.10	0.75		15.85		0.64		1.14		10605	2621
MKM-16	16	16.72		0.75		16.85		0.64		1.14		11312	2953
MKM-17	17	17.72		0.75		17.85		0.64		1.14		12091	3308
MKM-18	18	18.72		0.75		18.85		0.64		1.14		12726	3685
MKM-19	19	19.86		0.91	+0.08	20.00	+0.33	0.80		1.65		15145	3627
MKM-20	20	20.86		0.91	-0.00	21.10	-0.00	0.80		1.65		15942	4196
MKM-21	21	21.86		0.91		22.04		0.80		1.65		16739	4444
MKM-22	22	23.00		0.91		23.18		0.80		1.65		17536	5657
MKM-23	23	24.00	+0.00	0.91		24.19		0.80		1.65		18333	6166
MKM-24	24	25.00	-0.15	0.91		25.20		0.80	+0.05	1.65		19131	6697
MKM-25	25	26.26		1.07		26.45		0.94	-0.05	1.90		23415	7653
MKM-26	26	27.26		1.07		27.50		0.94		1.90		24352	8376
MKM-28	28	29.26		1.07		29.50		0.94		1.90		26225	9596
MKM-29	29	30.26		1.07		30.50		0.94		1.90		27161	10242
MKM-30	30	31.32		1.22		31.55		1.10		2.16		32881	9817
MKM-32	32	33.32		1.22		33.57		1.10		2.16		35073	11131
MKM-33	33	34.32		1.22		34.57		1.10		2.16		36169	11789
MKM-34	34	35.32	+0.00	1.22		35.57	+0.40	1.10		2.16		37265	12469
MKM-35	35	36.42	-0.20	1.22		36.70	-0.00	1.10		2.40	+0.08	38361	14414
MKM-36	36	37.42		1.22		37.70		1.10		2.40	-0.13	39457	15194
MKM-37	37	38.42		1.22		38.70		1.10		2.40		40553	15997
MKM-38	38	39.42		1.22		39.70		1.10		2.40		41649	16824
MKM-39	39	40.60		1.42		40.90		1.25		2.75		44350	16130
MKM-40	40	41.60		1.42		41.90		1.25		2.75		45487	16904
MKM-41	41	42.60		1.42		42.92		1.25		2.75		46624	17780
MKM-42	42	43.60		1.42		43.93		1.25		2.75		47761	18636
MKM-43	43	44.72	+0.00	1.42		45.00		1.25		3.00		48899	20883
MKM-44	44	45.72	-0.25	1.42		46.02	+0.50	1.25		3.00		50036	21903
MKM-45	45	46.72		1.42		47.08	-0.00	1.25		3.00		51173	23143
MKM-47	47	48.80		1.42		49.18		1.25		3.00		53447	26412
MKM-48	48	49.80		1.42		50.18		1.25		3.00		54584	27474
MKM-50	50	51.92		1.42	+0.10	52.30		1.25		3.25		56859	31907
MKM-52	52	53.92		1.42	-0.00	54.30		1.25		3.25		59133	34360
MKM-53	53	54.92		1.42		55.32		1.25	+0.08	3.25		60270	35132
MKM-55	55	57.00		1.42		57.38		1.25	-0.08	3.50		62545	37976
MKM-56	56	58.00		1.42		58.40		1.25		3.50		63682	38667
MKM-58	58	60.00		1.42		60.43		1.25		3.50		65956	40048
MKM-59	59	61.08		1.42		61.54		1.25		3.50		67093	42368
MKM-60	60	62.14		1.42		62.57		1.25		3.50		68231	44329
MKM-61	61	63.24	+0.00	1.42		63.65	+0.63	1.25	-0.00	3.76		69368	47174
MKM-62	62	64.24	-0.30	1.42		64.70		1.25		3.76		70505	47947
MKM-63	63	65.24		1.42		65.70		1.25		3.76		71642	48720
MKM-64	64	66.34		1.42		66.77		1.25		3.76		72779	51703
MKM-65	65	67.34		1.42		67.82		1.25		3.76		73916	52511
MKM-66	66	68.34		1.42		68.80		1.25		3.76		75054	53319

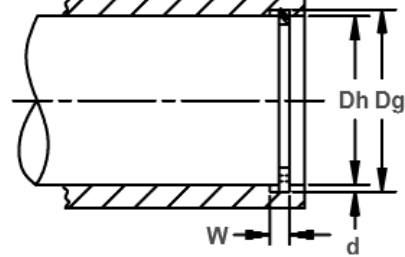
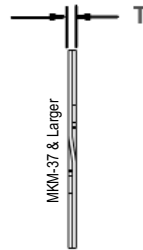
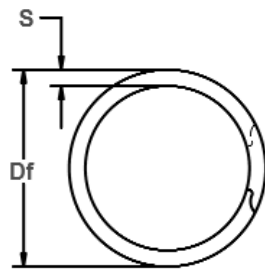

Free Diameter & Ring Measurements

Housing Diameter & Groove Dimensions

RING NO.	HOUSING DIAMETER (mm)	GROOVE SIZE				RING SIZE						THRUST LOAD (N)	
		DIAMETER		WIDTH		FREE DIAMETER		THICKNESS		SECTION		RING Safety factor of 3	GROOVE Safety factor of 2
		Dh	Dg	Tol.	W	Tol.	Df	Tol.	T	Tol.	S		
MKM-67	67	69.40		1.42		69.90		1.25		3.76		76191	55515
MKM-68	68	70.44		1.42		70.94		1.25		4.01	+0.08	77328	57282
MKM-69	69	71.44		1.42	+0.10	71.94	+0.63	1.25		4.01	-0.13	78465	58125
MKM-70	70	72.44		1.42	-0.00	72.94	-0.00	1.25		4.01		79602	58967
MKM-71	71	73.44		1.42		73.99		1.25		4.01		80740	59809
MKM-72	72	74.54		1.42		75.04		1.25		4.27		81877	63137
MKM-75	75	77.54		1.42		78.07		1.25		4.27		85288	65768
MKM-78	78	80.60		1.73		81.21		1.55		4.27		109988	70015
MKM-80	80	82.64		1.73		83.22		1.55		4.52		112808	72915
MKM-82	82	84.70		1.73		85.28		1.55	+0.08	4.52	-0.08	115628	76436
MKM-85	85	87.80	+0.00	1.73		88.38		1.55		4.78		119858	82167
MKM-88	88	90.84	-0.30	1.73		91.45	+0.76	1.55		4.78		124089	86282
MKM-90	90	92.94		1.73		93.58	-0.00	1.55		5.03		126909	91350
MKM-92	92	95.00		1.73		95.66		1.55		5.03		129729	95286
MKM-95	95	98.00		1.73		98.69		1.55		5.03		133959	98393
MKM-98	98	101.14		1.73		101.83		1.55		5.28		138190	106237
MKM-100	100	103.14		1.73		103.83		1.55		5.28		141010	108405
MKM-102	102	105.30		1.73		106.00		1.55		5.54	+0.10	143830	116208
MKM-105	105	108.30		1.73	+0.13	109.00		1.55		5.54	-0.15	148060	119626
MKM-108	108	111.46		1.73	-0.00	112.22		1.55		5.80		152291	129009
MKM-110	110	113.46		1.73		114.25		1.55		5.80		155111	131398
MKM-112	112	115.60		1.73		116.44	+0.90	1.55		6.05		157931	139201
MKM-115	115	118.60		1.73		119.44	-0.00	1.55		6.05		162161	142929
MKM-120	120	123.70		2.00		124.54		1.83		6.35		199779	153286
MKM-125	125	128.70		2.00		129.59		1.83		6.35		208103	159673
MKM-130	130	133.80		2.00		134.71		1.83		6.35		216427	170548
MKM-135	135	138.80		2.00		139.74		1.83		6.35		224752	177108
MKM-140	140	143.90	+0.00	2.00		144.87	+1.14	1.83		6.35		233076	188501
MKM-145	145	149.00	-0.35	2.00		150.04	-0.00	1.83		6.35		241400	200239
MKM-150	150	154.00		2.00		155.07		1.83		6.35		249724	207144
MKM-155	155	159.60		2.40		160.72		2.18		7.92		307401	246156
MKM-160	160	164.60		2.40		165.74		2.18		7.92		317318	254096
MKM-165	165	169.60		2.40		170.77	+1.40	2.18	+0.10	7.92		327234	262037
MKM-170	170	174.80		2.40		176.05	-0.00	2.18	-0.10	7.92		337150	281716
MKM-175	175	179.80		2.40		181.05		2.18		7.92		347066	290001
MKM-180	180	185.08		2.40		186.38		2.18		7.92		356982	315687
MKM-185	185	190.08		2.40		191.10		2.18		7.92		366899	324456
MKM-190	190	195.08	+0.00	2.40	+0.15	196.45		2.18		7.92	+0.10	376815	333225
MKM-195	195	200.34	-0.40	2.40	-0.00	201.74		2.18		7.92	-0.20	386731	359498
MKM-200	200	205.34		2.40		206.76		2.18		7.92		396647	368716
MKM-210	210	215.60		2.40		217.10		2.18		9.52		416479	406002
MKM-220	220	225.84		2.40		227.40	+1.65	2.18	-0.00	9.52		436312	443564
MKM-230	230	236.10		2.40		237.73		2.18		9.52		456144	484371
MKM-240	240	246.10		2.40		247.80		2.18		9.52		475976	505431
MKM-250	250	256.36		2.40		258.10		2.18		9.52		495809	548931
MKM-260	260	266.60		2.40		268.43		2.18		9.52		515641	592431
MKM-270	270	276.60		2.40		278.50		2.18		9.52		535474	615217
MKM-280	280	286.86		2.40		288.82		2.18		9.52		555306	663136

MCM Spiral Shaft Rings

External, Medium Duty, Metric

These rings offer the greatest economy in price and size. They are able to handle approximately twice the thrust capacity of the DCL series.

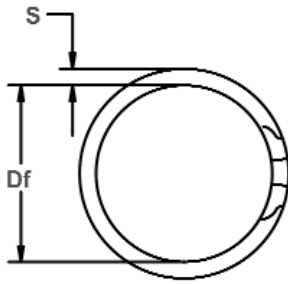

Free Diameter & Ring Measurements

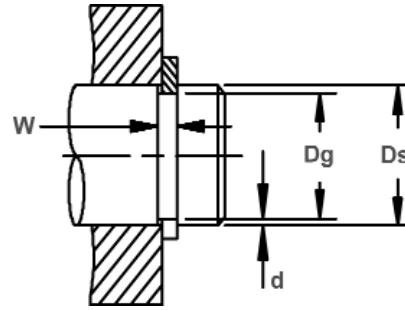
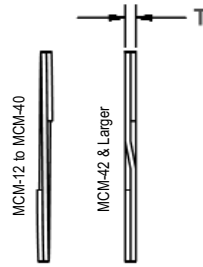

Shaft Diameter & Groove Dimensions

RING NO.	SHAFT DIAMETER (mm)	GROOVE SIZE				RING SIZE				THRUST LOAD (N)			
		DIAMETER		WIDTH		FREE DIAMETER		THICKNESS		SECTION	RING Safety factor of 3	GROOVE Safety factor of 2	
		Dg	Tol.	W	Tol.	Df	Tol.	T	Tol.				S
MCM-12	12	11.34	+ 0.10 -0.00	0.75	+ 0.08 -0.00	11.21	+ 0.00 -0.33	0.64	+0.05 -0.05	1.14	+0.08 -0.13	8484	2246
MCM-13	13	12.28		0.75		12.15		0.64		1.14		9191	2951
MCM-14	14	13.28		0.75		13.15		0.64		1.14		9898	3480
MCM-15	15	14.28		0.75		14.15		0.64		1.14		10605	3729
MCM-16	16	15.14		0.75		14.98		0.64		1.40		11312	4750
MCM-17	17	16.14		0.75		15.98		0.64		1.40		12091	5047
MCM-18	18	17.14		0.75		16.98		0.64		1.40		12726	5344
MCM-19	19	18.14		0.91		17.98		0.80		1.65		15145	5573
MCM-20	20	19.14		0.91		18.98		0.80		1.65		15942	5938
MCM-21	21	20.14		0.91		19.98		0.80		1.65		16739	6235
MCM-22	22	21.00		0.91		20.82		0.80		1.65		17536	7595
MCM-23	23	22.00	0.91	21.82	0.80	1.65	18333	7941					
MCM-24	24	23.00	0.91	22.80	0.80	1.65	19131	8286					
MCM-25	25	23.84	+0.13 -0.00	1.07	+ 0.00 -0.38	23.64	+0.08 -0.13	0.94	+0.08 -0.08	1.90	+0.08 -0.13	23415	10012
MCM-26	26	24.84		1.07		24.61		0.94		1.90		24352	10412
MCM-27	27	25.84		1.07		25.61		0.94		1.90		25288	10813
MCM-28	28	26.84		1.07		26.61		0.94		1.90		26225	11213
MCM-29	29	27.84		1.07		27.61		0.94		1.90		27161	11614
MCM-30	30	28.68		1.22		28.45		1.10		2.16		32881	13671
MCM-32	32	30.68		1.22		30.43		1.10		2.16		35073	14583
MCM-33	33	31.68		1.22		31.42		1.10		2.40		36169	15039
MCM-34	34	32.68		1.22		32.43		1.10		2.40		37265	15494
MCM-35	35	33.60		1.22		33.32		1.10		2.40		38361	16917
MCM-36	36	34.60	1.22	34.32	1.10	2.40	39457	17400					
MCM-37	37	35.66	1.22	35.36	1.10	2.40	40553	17883					
MCM-38	38	36.60	1.22	36.32	1.10	2.40	41649	18367					
MCM-39	39	37.48	+ 0.25 -0.00	1.42	+ 0.00 -0.50	37.25	+0.08 -0.08	1.25	+0.08 -0.08	2.75	+0.08 -0.13	44350	20466
MCM-40	40	38.48		1.42		38.18		1.25		2.75		45487	20991
MCM-42	42	40.40		1.42		40.10		1.25		2.75		47761	23200
MCM-43	43	41.38		1.42		41.04		1.25		3.00		48899	24049
MCM-44	44	42.38		1.42		42.06		1.25		3.00		50036	24609
MCM-45	45	43.28		1.42		42.95		1.25		3.00		51173	26722
MCM-47	47	45.22		1.42		44.85		1.25		3.25		53447	29207
MCM-48	48	46.20		1.42		45.85		1.25		3.25		54584	29829
MCM-50	50	48.20		1.42		47.82		1.25		3.25		56859	31072
MCM-52	52	50.00		1.42		49.62		1.25		3.25		59133	35905
MCM-53	53	51.00	+ 0.30 -0.00	1.42	+ 0.00 -0.63	50.62	+0.08 -0.08	1.25	+0.08 -0.08	3.25	+0.08 -0.13	60270	36595
MCM-54	54	52.00		1.42		51.62		1.25		3.25		61408	37286
MCM-55	55	53.00		1.42		52.62		1.25		3.50		62545	37976
MCM-56	56	54.00		1.42		53.62		1.25		3.50		63682	38667
MCM-58	58	55.86		1.42		55.43		1.25		3.50		65956	42851
MCM-59	59	56.86		1.42		56.43		1.25		3.50		67093	43590
MCM-60	60	57.86		1.42		57.43		1.25		3.50		68231	44329
MCM-61	61	58.76		1.42		58.36		1.25		3.50		69368	47174
MCM-62	62	59.76		1.42		59.30		1.25		3.76		70505	47947

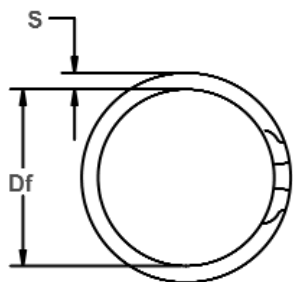

MCM-12 to MCM-40



MCM-42 & Larger

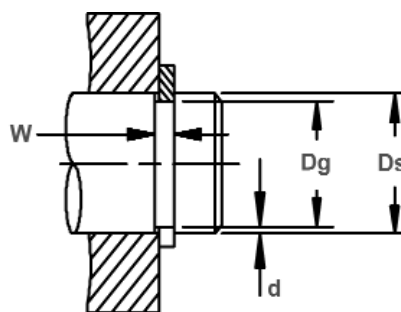

Free Diameter & Ring Measurements

Shaft Diameter & Groove Dimensions

RING NO.	SHAFT DIAMETER (mm)	GROOVE SIZE				RING SIZE				THRUST LOAD (N)			
		DIAMETER		WIDTH		FREE DIAMETER		THICKNESS		SECTION		RING Safety factor of 3	GROOVE Safety factor of 2
		Dg	Tol.	W	Tol.	Df	Tol.	T	Tol.	S	Tol.		
MCM-63	63	60.76		1.42		60.30		1.25		3.76		71642	48720
MCM-64	64	61.76		1.42		61.25		1.25		3.76		72779	49494
MCM-65	65	62.66		1.42		62.20	+0.00	1.25		3.76		73916	50267
MCM-66	66	63.64		1.42		63.16	-0.63	1.25		3.76	+0.08	75054	53775
MCM-67	67	64.56		1.42	+0.10	64.16		1.25		3.76	-0.13	76191	56440
MCM-68	68	65.56		1.42	-0.00	65.08		1.25		4.00		77328	57282
MCM-69	69	66.56		1.42		66.06		1.25		4.00		78465	58125
MCM-70	70	67.56		1.42		67.08		1.25		4.00		79602	58967
MCM-71	71	68.56		1.42		68.04		1.25	+0.08	4.00		80740	59809
MCM-72	72	69.50		1.42		69.00	+0.00	1.25	-0.08	4.27		81877	62143
MCM-75	75	72.46	+0.30	1.42		71.93	-0.76	1.25		4.27		85288	65768
MCM-78	78	75.40	-0.00	1.73		74.84		1.55		4.27		109988	70015
MCM-80	80	77.36		1.73		76.80		1.55		4.52		112808	72915
MCM-82	82	79.30		1.73		78.72		1.55		4.52		115628	76436
MCM-85	85	82.20		1.73		81.62		1.55		4.77		119858	82167
MCM-88	88	85.16		1.73		84.53		1.55		4.77		124089	86282
MCM-90	90	87.06		1.73		86.43		1.55		5.03		126909	91350
MCM-95	95	92.00		1.73		91.37		1.55		5.03		133959	98393
MCM-100	100	96.86		1.73		96.10	+0.00	1.55		5.28		141010	108405
MCM-105	105	101.70		1.73	+0.13	100.94	-1.00	1.55		5.53	+0.10	148060	119626
MCM-110	110	106.54		1.73	-0.00	105.75		1.55		5.80	-0.15	155111	131398
MCM-115	115	111.40		1.73		110.59		1.55		6.05		162161	142929
MCM-120	120	116.30		2.00		115.49		1.83		6.35		199779	153286
MCM-125	125	121.30		2.00		120.44		1.83		6.35		208103	159673
MCM-130	130	126.20		2.00		125.34		1.83		6.35		216427	170548
MCM-135	135	131.10		2.00		130.20		1.83		6.35		224752	181769
MCM-140	140	136.08	+0.35	2.00		135.14	+0.00	1.83		6.35		233076	189468
MCM-145	145	141.00	-0.00	2.00		140.00	-1.30	1.83		6.35		241400	200293
MCM-150	150	146.00		2.00		145.00		1.83		6.35		249724	207144
MCM-155	155	150.40		2.40		149.33		2.18		7.92		307401	246156
MCM-160	160	155.40		2.40		154.31		2.18		7.92		317318	254096
MCM-165	165	160.40		2.40		159.23	+0.00	2.18		7.92		327234	262037
MCM-170	170	165.20		2.40		164.00	-1.52	2.18	+0.10	7.92		337150	281716
MCM-175	175	170.20		2.40		169.00		2.18	-0.10	7.92		347066	290001
MCM-180	180	175.00		2.40		173.78		2.18		7.92		356982	310716
MCM-185	185	180.00		2.40		178.70		2.18		7.92		366899	319347
MCM-190	190	185.00	+0.40	2.40	+0.15	183.70		2.18		7.92	+0.10	376815	327978
MCM-195	195	189.80	-0.00	2.40	-0.00	188.43		2.18		7.92	-0.20	386731	350073
MCM-200	200	194.80		2.40		193.43		2.18		7.92		396647	359049
MCM-210	210	204.40		2.40		202.93		2.18		9.52		416479	406002
MCM-220	220	214.20		2.40		212.65	+0.00	2.18		9.52		436312	440526
MCM-230	230	224.20		2.40		222.60	-1.78	2.18		9.52		456144	460550
MCM-240	240	234.00		2.40		232.32		2.18		9.52		475976	497145
MCM-250	250	243.60		2.40		241.83		2.18		9.52		495809	552383
MCM-260	260	253.40		2.40		251.57		2.18		9.52		515641	592431
MCM-270	270	263.20		2.40		261.30		2.18		9.52		535474	633806
MCM-280	280	273.00		2.40		271.04		2.18		9.52		555306	676670



MKR Spiral Housing Rings

Internal, Medium-Heavy Duty Metric

With load bearing capacities closer to the Heavy-duty series, and almost universal groove dimensions, these rings offer greatest ease of assembly with greatest thrust capacity.

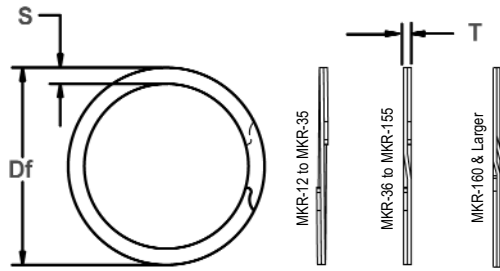

Free Diameter & Ring Measurements

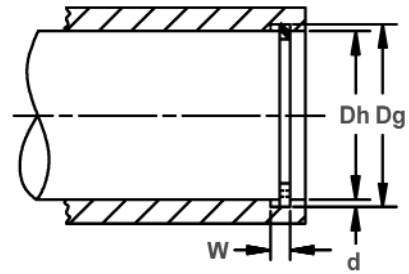

Housing Diameter & Groove Dimensions

RING NO.	HOUSING DIAMETER (mm)	GROOVE SIZE				RING SIZE						THRUST LOAD (N)	
		DIAMETER		WIDTH		FREE DIAMETER		THICKNESS		SECTION		RING Safety factor of 3	GROOVE Safety factor of 2
		Dh	Dg	Tol.	W	Tol.	Df	Tol.	T	Tol.	S		
MKR-12	12	12.60		1.00		12.73		0.89		1.14		10641	929
MKR-13	13	13.60		1.00		13.73		0.89		1.14		11528	1067
MKR-14	14	14.76		1.00		14.89		0.89		1.14		12415	1555
MKR-15	15	15.86		1.00		16.01		0.89		1.14		13302	2026
MKR-16	16	16.86		1.00		17.01		0.89		1.14		14188	2275
MKR-17	17	17.90		1.00		18.05		0.89		1.40		15075	2711
MKR-18	18	18.90	+0.08	1.00	+0.08	19.05	+0.33	0.89		1.40		15962	3005
MKR-19	19	20.00	-0.08	1.00	-0.00	20.15	-0.00	0.89		1.40		16849	3700
MKR-20	20	21.06		1.17		21.21		1.07		1.65		21323	3707
MKR-21	21	22.12		1.17		22.30		1.07		1.65		22389	4352
MKR-22	22	23.16		1.17		23.34		1.07		1.65		23455	4910
MKR-23	23	24.22		1.17		24.50		1.07	+0.05	1.65		24521	5831
MKR-24	24	25.26		1.17		25.46		1.07	-0.05	1.90		25587	6398
MKR-25	25	26.40		1.17		26.60		1.07		1.90		26653	7693
MKR-26	26	27.42		1.17		27.62		1.07		1.90	+0.08	27719	8389
MKR-28	28	29.48		1.42		29.71		1.27		1.98	-0.13	32350	7734
MKR-29	29	30.52		1.42		30.77		1.27		1.98		33506	8531
MKR-30	30	31.56		1.42		31.81		1.27		2.24		34661	9422
MKR-32	32	33.80		1.42		34.05		1.27		2.50		36972	12416
MKR-33	33	34.84		1.42		35.12		1.27		2.50		38127	13561
MKR-34	34	35.88	+0.10	1.42		36.16	+0.38	1.27		2.50		39283	14638
MKR-35	35	36.90	-0.10	1.42		37.18	-0.00	1.27		2.50		40438	15603
MKR-36	36	37.90		1.42		38.18		1.27		2.50		41593	16429
MKR-37	37	39.00		1.42	+0.10	39.28		1.27		2.75		42749	18368
MKR-38	38	40.00		1.42	-0.00	40.28		1.27		2.75		43904	19289
MKR-39	39	41.06		1.42		41.37		1.27		2.75		45059	21028
MKR-40	40	42.14		1.73		42.44		1.57		3.00		57132	18286
MKR-41	41	43.24		1.73		43.54		1.57		3.00		58560	20065
MKR-42	42	44.34		1.73		44.64		1.57		3.00		59988	21951
MKR-43	43	45.36		1.73		45.69		1.57		3.00		61417	23283
MKR-44	44	46.38	+0.13	1.73		46.81	+0.50	1.57		3.00		62845	25023
MKR-45	45	47.40	-0.13	1.73		47.73	-0.00	1.57		3.00		64273	25764
MKR-47	47	49.54		1.73		49.84		1.57		3.25		67130	29617
MKR-48	48	50.54		1.73		50.90		1.57		3.25		68558	31168
MKR-50	50	52.64		1.73		53.00		1.57		3.50		71415	35192
MKR-52	52	54.84		2.18		55.22		1.98	+0.08	3.58		93667	32153
MKR-53	53	55.88		2.18		56.26		1.98	-0.08	3.58		95468	33791
MKR-55	55	57.94		2.18		58.34		1.98		3.58		99071	37098
MKR-56	56	58.94		2.18		59.34		1.98		3.58		100872	38358
MKR-58	58	61.20		2.18		61.63		1.98		4.77		104475	49567
MKR-59	59	62.22	+0.15	2.18	+0.13	62.65	+0.63	1.98		4.77		106276	47432
MKR-60	60	63.30	-0.15	2.18	-0.00	63.73	-0.00	1.98		4.77		108077	50494
MKR-61	61	64.30		2.18		64.76		1.98		4.77	+0.10	109879	52323
MKR-62	62	65.36		2.18		65.82		1.98		4.77	-0.15	111680	54926
MKR-63	63	66.40		2.18		66.86		1.98		4.77		113481	57265
MKR-64	64	67.40		2.18		67.90		1.98		4.77		115282	59331
MKR-65	65	68.50		2.62		69.00		2.36		4.77		132909	50522
MKR-66	66	69.50		2.62		70.03		2.36		4.77		134954	52189

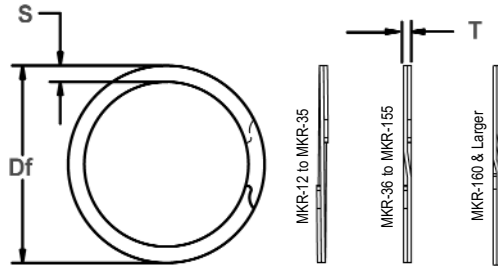

Free Diameter & Ring Measurements

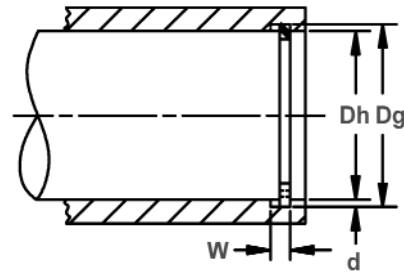

Housing Diameter & Groove Dimensions

RING NO.	HOUSING DIAMETER		GROOVE SIZE				FREE DIAMETER		RING SIZE		SECTION		THRUST LOAD (N)	
	(mm)		DIAMETER		WIDTH		DIAMETER		THICKNESS		SECTION		RING Safety factor of 3	GROOVE Safety factor of 2
	Dh	Dg		Tol.	W	Tol.	Df	Tol.	T	Tol.	S	Tol.		
MKR-67	67	70.60			2.62		71.13		2.36		4.77		136998	55235
MKR-68	68	71.66			2.62		72.19		2.36		4.77		139043	57735
MKR-69	69	72.74			2.62		73.27	+0.63	2.36		4.77		141088	60650
MKR-70	70	73.80			2.62		74.33	-0.00	2.36		4.77		143133	63315
MKR-71	71	74.80			2.62		75.36		2.36		4.77		145177	65251
MKR-72	72	75.86			2.62		76.42		2.36		4.77		147222	68052
MKR-75	75	79.00			2.62		79.58		2.36		4.77		153356	76340
MKR-78	78	82.26			3.05		82.95		2.82		6.35	+0.10	190578	75542
MKR-80	80	84.36			3.30		85.02		2.82		6.35	-0.15	195464	80623
MKR-82	82	86.40			3.05		87.06		2.82		6.35		200351	85092
MKR-85	85	89.58	+0.15		3.05	+0.13	90.21		2.82	+0.08	6.35		207681	94335
MKR-88	88	92.78	-0.15		3.05	-0.00	93.44	+0.76	2.82	-0.08	6.35		215011	105482
MKR-90	90	94.88			3.05		95.54	-0.00	2.82		6.35		219897	112323
MKR-92	92	97.00			3.05		97.68		2.82		6.35		224784	120232
MKR-95	95	100.20			3.05		100.88		2.82		6.35		232114	132913
MKR-98	98	103.40			3.05		104.11		2.82		6.35		239444	146909
MKR-100	100	105.40			3.05		106.11		2.82		6.35		244330	152534
MKR-102	102	107.60			3.05		108.31		2.82		6.35		249217	164421
MKR-105	105	110.60			3.05		111.34		2.82		7.92		256547	176970
MKR-108	108	113.60			3.05		114.36		2.82		7.92		263877	186814
MKR-110	110	115.74			3.05		116.50		2.82		7.92		268763	198334
MKR-112	112	117.84			3.05		118.60	+0.90	2.82		7.92		273650	208838
MKR-115	115	121.00			3.05		121.83	-0.00	2.82		7.92		280980	227125
MKR-120	120	126.20			3.05		127.04		2.82		7.92		293197	254750
MKR-125	125	131.50			3.05		132.39		2.82		7.92		305413	280507
MKR-130	130	136.70			3.05		137.61		2.82		7.92		317630	300704
MKR-135	135	141.90			3.53		142.90		3.23		9.52		377802	314888
MKR-140	140	146.90	+0.18		3.53	+0.15	147.91	+1.14	3.23	+0.10	9.52		391795	333502
MKR-145	145	151.90	-0.18		3.53	-0.00	152.97	-0.00	3.23	-0.10	9.52		405788	345412
MKR-150	150	156.90			3.53		158.02		3.23		9.52	+0.10	419780	357323
MKR-155	155	161.90			3.53		163.04		3.23		9.52	-0.20	433773	369234
MKR-160	160	167.10			4.42		168.27		4.20		7.92		582234	392192
MKR-165	165	172.36			4.42		173.55	+1.40	4.20		7.92		600429	419259
MKR-170	170	177.70			4.42		178.94	-0.00	4.20		7.92		618624	451919
MKR-175	175	182.80			4.42		184.09		4.20		7.92		636819	471252
MKR-180	180	188.00			4.42		189.30		4.20		7.92		655014	497145
MKR-185	185	193.24	+0.20		5.30	+0.20	194.59		4.80	+0.13	9.52		769381	526283
MKR-190	190	198.64	-0.20		5.30	-0.00	200.04		4.80	-0.13	9.52		790175	566745
MKR-195	195	203.74			5.30		205.14		4.80		9.52		810969	588392
MKR-200	200	208.90			5.30		210.37		4.80		9.52		831763	614527
MKR-210	210	219.40			5.30		220.92	+1.78	4.80		9.52		873351	681503
MKR-220	220	229.90			5.30		231.52	-0.00	4.80		9.52		914940	751932
MKR-230	230	240.20			5.30		241.90		4.80		9.52		956528	809932
MKR-240	240	250.90			5.30		252.65		4.80		9.52		998116	903147
MKR-250	250	260.90			5.30		262.70		4.80		9.52		1039704	940778
MKR-260	260	271.40			5.30		273.20		4.80		9.52		1081292	1023290
MKR-270	270	281.40			5.30		283.20		4.80		9.52		1122880	1062648
MKR-280	280	291.40			5.30		293.30		4.80		9.52		1164468	1102005



MCR Spiral Shaft Rings

External, Medium-Heavy Duty, Metric

With load bearing capacities closer to the Heavy-duty series, and almost universal groove dimensions, these rings offer greatest ease of assembly with greatest thrust capacity

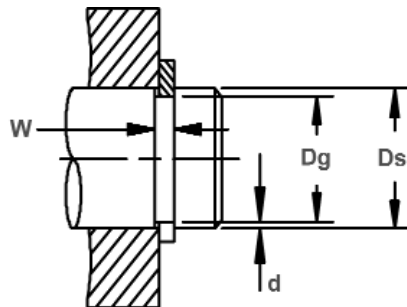
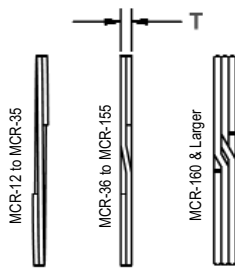
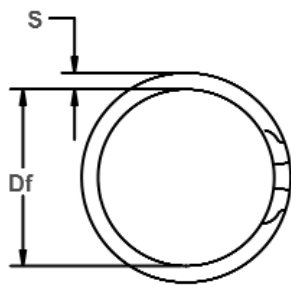

Free Diameter & Ring Measurements

Shaft Diameter & Groove Dimensions

RING NO.	SHAFT DIAMETER (mm)	GROOVE SIZE				RING SIZE				THRUST LOAD (N)													
		DIAMETER		WIDTH		FREE DIAMETER		THICKNESS		SECTION		RING Safety factor of 3	GROOVE Safety factor of 2										
		Ds	Dg	Tol.	W	Tol.	Df	Tol.	T	Tol.	S			Tol.									
MCR-12	12	11.34	+0.08 -0.08	1.00	+0.08 -0.00	11.21	+0.00 -0.33	0.89	+0.05 -0.05	1.14	+0.08 -0.13	10641	1384										
MCR-13	13	12.34		1.00		12.21		0.89		1.14		11528	1678										
MCR-14	14	13.30		1.00		13.15		0.89		1.14		12415	2069										
MCR-15	15	14.28		1.00		14.13		0.89		1.14		13302	2499										
MCR-16	16	15.28		1.00		15.13		0.89		1.40		14188	2837										
MCR-17	17	16.20		1.00		16.05		0.89		1.40		15075	3609										
MCR-18	18	17.14		1.17		16.96		1.07		1.65		19190	3571										
MCR-19	19	18.12		1.17		17.94		1.07		1.65		20256	4148										
MCR-20	20	19.08		1.17		18.90		1.07		1.65		21323	4878										
MCR-21	21	20.08		1.17		19.88		1.07		1.65		22389	5397										
MCR-22	22	20.94		1.17		20.74		1.07		1.90		23455	6765										
MCR-23	23	21.94		1.17		21.74		1.07		1.90		24521	7511										
MCR-24	24	22.94		1.17		22.74		1.07		1.90		25587	8297										
MCR-25	25	23.88		1.17		23.68		1.07		1.90		26653	9608										
MCR-26	26	24.84		1.17		24.69		1.07		1.90		27719	10412										
MCR-27	27	25.80		+0.10 -0.10		1.42		+0.10 -0.00		25.55		+0.00 -0.40	1.27	+0.08 -0.08	2.24	+0.08 -0.13	31195	8706					
MCR-28	28	26.80				1.42				26.55			1.27		2.24		32350	9487					
MCR-29	29	27.74				1.42				27.46			1.27		2.24		33506	10629					
MCR-30	30	28.68				1.42				28.40			1.27		2.24		34661	12032					
MCR-32	32	30.60				1.42				30.32			1.27		2.50		36972	14621					
MCR-33	33	31.50				1.42				31.22			1.27		2.50		38127	16774					
MCR-34	34	32.40	1.42		32.12	1.27	2.50		39283	18781													
MCR-35	35	33.36	1.42		33.06	1.27	2.75		40438	19917													
MCR-36	36	34.28	1.42		33.98	1.27	2.75		41953	21377													
MCR-37	37	35.28	1.42		34.88	1.27	2.75		42749	21971													
MCR-38	38	36.20	1.42		35.90	1.27	2.75		43904	23614													
MCR-39	39	37.70	+0.13 -0.13		1.73	+0.10 -0.00	37.40		+0.00 -0.50	1.58	+0.08 -0.08		3.00		+0.08 -0.13		56058	22989					
MCR-40	40	38.12			1.73		37.76			1.58			3.00				57496	24462					
MCR-42	42	40.08			1.73		39.72			1.58			3.00				60370	27840					
MCR-43	43	41.08			1.73		40.69			1.58			3.00				61808	28503					
MCR-44	44	41.96			1.73		41.60			1.58			3.25				63245	29166					
MCR-45	45	42.90			1.73		42.54			1.58			3.25				64683	32625					
MCR-47	47	44.80			1.73		44.39			1.58			3.25				67557	35698					
MCR-48	48	45.80			1.73		45.39			1.58			3.25				68995	36457					
MCR-50	50	47.70			1.73		47.29			1.58			3.25				71870	39703					
MCR-52	52	49.66			+0.15 -0.15		2.18			+0.13 -0.00			49.28				+0.00 -0.63	1.98	+0.08 -0.08	3.58	+0.08 -0.13	93667	42009
MCR-53	53	50.60					2.18						50.25					1.98		3.58		95468	43914
MCR-54	54	51.50					2.18						51.11					1.98		3.58		97270	46607
MCR-55	55	52.46					2.18						52.05					1.98		3.58		99071	48230
MCR-56	56	53.46		2.18			53.06	1.98				3.58	100872	49107									
MCR-58	58	55.26		2.18			54.83	1.98				3.58	104475	54865									
MCR-59	59	56.26		2.18			55.75	1.98				3.58	106276	55811									
MCR-60	60	57.20		2.18			56.77	1.98				3.58	108077	58000									
MCR-61	61	58.20		2.18			57.73	1.98				3.58	109879	58967									
MCR-62	62	59.16		2.18			58.70	1.98				3.58	111680	60790									

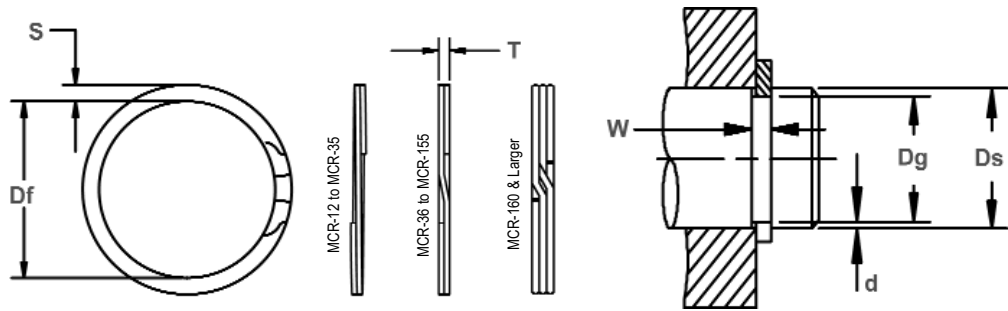

Free Diameter & Ring Measurements

Shaft Diameter & Groove Dimensions

RING NO.	SHAFT DIAMETER (mm)	GROOVE SIZE				RING SIZE				THRUST LOAD (N)			
		DIAMETER		WIDTH		FREE DIAMETER		THICKNESS		SECTION		RING Safety factor of 3	GROOVE Safety factor of 2
		Ds	Dg	Tol.	W	Tol.	Df	Tol.	T	Tol.	S		
MCR-63	63	60.10		2.18		59.62		1.98		4.77		113481	63075
MCR-64	64	61.10		2.18		60.62		1.98		4.77		115282	64076
MCR-65	65	62.10		2.18		61.62	+0.00	1.98		4.77		117084	65078
MCR-66	66	63.04		2.18		62.58	-0.63	1.98		4.77		118885	67446
MCR-67	67	63.90		2.18		64.38		1.98		4.77		120686	71706
MCR-68	68	64.90		2.18		64.40		1.98		4.77		122488	72777
MCR-69	69	65.90		2.18		65.38		1.98		4.77		124289	73847
MCR-70	70	66.86		2.62		66.33		2.36		4.77		143133	75884
MCR-71	71	67.70		2.62		67.15		2.36		4.77		145177	80890
MCR-72	72	68.70		2.62		68.20		2.36		4.77		147222	82029
MCR-75	75	71.54	+0.15	2.62	+0.13	71.00	+0.00	2.36	+0.08	4.77	+0.10	153356	89590
MCR-78	78	74.40	-0.15	2.62	-0.00	73.82	-0.75	2.36	-0.08	4.77	-0.15	159491	96943
MCR-80	80	76.30		2.62		75.69		2.36		4.77		163580	102191
MCR-82	82	78.20		2.62		77.57		2.36		4.77		167670	107577
MCR-85	85	81.10		2.62		80.44		2.36		4.77		173804	114447
MCR-88	88	84.00		2.62		83.34		2.36		4.77		179938	121524
MCR-90	90	85.90		3.05		85.27		2.82		6.35		219897	127393
MCR-95	95	90.60		3.05		89.91		2.82		6.35		232114	144310
MCR-100	100	95.40		3.05		94.70		2.82		6.35		244330	158810
MCR-105	105	100.32		3.05		99.61	+0.00	2.82		6.35		256547	169651
MCR-110	110	105.32		3.05		104.60	-1.00	2.82		6.35		268763	177729
MCR-115	115	110.16		3.05		109.40		2.82		6.35		280980	192160
MCR-120	120	114.92		3.05		114.03		2.82		6.35		293197	210458
MCR-125	125	119.70		3.05		118.81		2.82		6.35		305413	228721
MCR-130	130	124.56		3.05		123.65		2.82		6.35		317630	244153
MCR-135	135	129.40		3.53		128.50		3.23		9.52		377802	261001
MCR-140	140	134.06	+0.18	3.53	+0.15	133.15	+0.00	3.23	+0.10	9.52		391795	287101
MCR-145	145	138.80	-0.18	3.53	-0.00	137.80	-1.27	3.23	-0.10	9.52		405788	310370
MCR-150	150	143.64		3.53		142.60		3.23		9.52		419780	329359
MCR-155	155	148.50		3.53		147.43		3.23		9.52		433773	347829
MCR-160	160	153.30		4.42		152.11		4.20		7.92		582234	370097
MCR-165	165	158.00		4.42		156.81		4.20		7.92		600429	398752
MCR-170	170	162.80		4.42		161.61	+0.00	4.20		7.92		618624	422573
MCR-175	175	167.60		4.42		166.41	-1.52	4.20		7.92		636819	447085
MCR-180	180	172.40		4.42		171.20		4.20		7.92	+0.10	655014	472288
MCR-185	185	177.40		4.42		176.18		4.20		7.92	-0.20	673208	485407
MCR-190	190	182.40	+0.20	5.30	+0.20	181.13		4.80	+0.13	9.52		790175	498526
MCR-195	195	186.60	-0.20	5.30	-0.00	185.33		4.80	-0.13	9.52		810969	565503
MCR-200	200	191.52		5.30		190.14		4.80		9.52		831763	585526
MCR-210	210	201.20		5.30		199.80		4.80		9.52		873351	638003
MCR-220	220	210.80		5.30		209.30	+0.00	4.80		9.52		914940	698765
MCR-230	230	220.36		5.30		218.74	-1.78	4.80		9.52		956528	765465
MCR-240	240	230.00		5.30		228.30		4.80		9.52		998116	828575
MCR-250	250	239.40		5.30		237.70		4.80		9.52		1039704	914885
MCR-260	260	249.20		5.30		247.50		4.80		9.52		1081292	969433
MCR-270	270	259.10		5.30		257.33		4.80		9.52		1122880	1016040
MCR-280	280	269.00		5.30		267.17		4.80		9.52		1164468	1063338

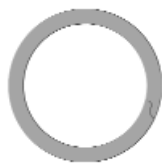

MKG Spiral Housing Rings

Internal, Heavy Duty, Metric

The greatest size range and thrust capacity make these rings the only choice for applications that require minimum deflection or thrust loads that demand a deep groove capacity.

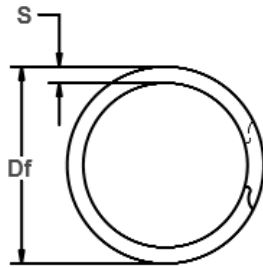

MKG-12 to MKG-19

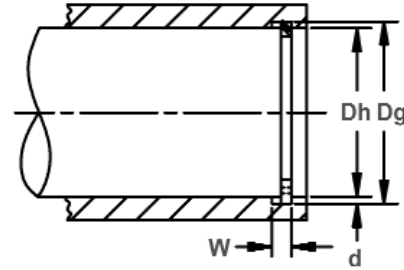
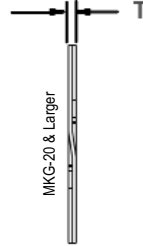

Free Diameter & Ring Measurements

Housing Diameter & Groove Dimensions

RING NO.	HOUSING DIAMETER (mm)		GROOVE SIZE				RING SIZE				THRUST LOAD (N)		
			DIAMETER		WIDTH		FREE DIAMETER		THICKNESS				SECTION
	Dh	Dg	Tol.	W	Tol.	Df	Tol.	T	Tol.	S	Tol.	3	2
MKG-12	12	12.70		0.70		12.89		0.60		1.14		7954	1794
MKG-13	13	13.75		1.00		13.95		0.89		1.14		11528	1421
MKG-14	14	14.85	+0.05	1.00		15.07		0.89		1.40		12415	1925
MKG-15	15	15.90	-0.05	1.00		16.14		0.89		1.40		13302	2318
MKG-16	16	16.95		1.00		17.15		0.89		1.40		14188	2660
MKG-17	17	18.05		1.00		18.32		0.89		1.65		15075	3507
MKG-18	18	19.10		1.00		19.39		0.89		1.65		15962	4089
MKG-19	19	20.17		1.00	+0.08	20.48		0.89		1.65		16849	4817
MKG-20	20	21.22		1.00	-0.00	21.51		0.89		1.90		17736	5556
MKG-21	21	22.26		1.00		22.56		0.89	+0.05	1.90		18622	6286
MKG-22	22	23.37		1.20		23.65		1.07	-0.05	1.90		23455	6200
MKG-23	23	24.42	+0.08	1.20		24.69		1.07		2.16		24521	7040
MKG-24	24	25.47	-0.08	1.20		25.73		1.07		2.16		25587	7819
MKG-25	25	26.67		1.20		27.03		1.07		2.16		26653	9992
MKG-26	26	27.77		1.20		28.07	+0.35	1.07		2.16	+0.08	27719	11102
MKG-27	27	28.87		1.40		29.11	-0.00	1.27		2.62	-0.13	31195	9571
MKG-28	28	29.87		1.40		30.10		1.27		2.62		32350	10153
MKG-29	29	30.95		1.40		31.21		1.27		2.62		33506	11428
MKG-30	30	32.00		1.40		32.28		1.27		2.62		34661	12552
MKG-31	31	33.05		1.40		33.32		1.27		2.62		35817	13599
MKG-32	32	34.00		1.40		34.23		1.27		2.62		36972	13830
MKG-34	34	36.20		1.40		36.46		1.27		3.00		39283	17447
MKG-35	35	37.30		1.40		37.55		1.27		3.00		40438	19195
MKG-36	36	38.40	+0.10	1.40	+0.10	38.68		1.27		3.00		41593	21326
MKG-37	37	39.40	-0.10	1.40	-0.00	39.60		1.27		3.00		42749	21876
MKG-38	38	40.50		1.40		40.77		1.27		3.00		43904	24484
MKG-40	40	42.50		1.75		42.91		1.57		3.25		57132	22319
MKG-42	42	44.60		1.75		45.01		1.57		3.25		59988	25347
MKG-45	45	47.70		1.75		48.13		1.57		3.25		64273	29964
MKG-46	46	48.80		1.75		49.28		1.57		3.25		65701	32717
MKG-47	47	49.90		1.75		50.32		1.57		4.01		67130	35606
MKG-48	48	51.00		1.75		51.46		1.57	+0.08	4.01		68558	38663
MKG-50	50	53.20		1.75		53.66		1.57	-0.08	4.01		71415	44490
MKG-52	52	55.45		2.15		55.91		1.98		4.27		93667	40681
MKG-55	55	58.55		2.15		59.28		1.98		4.27		99071	48699
MKG-57	57	60.65	+0.15	2.15	+0.20	60.93	+0.65	1.98		4.27	+0.10	102673	49284
MKG-58	58	61.75	-0.15	2.15	-0.00	62.66	-0.00	1.98		5.08	-0.15	104475	91487
MKG-60	60	63.95		2.15		64.39		1.98		5.08		108077	99943
MKG-62	62	65.95		2.15		66.40		1.98		5.08		111680	109065
MKG-63	63	67.05		2.15		67.74		1.98		5.08		113481	121272

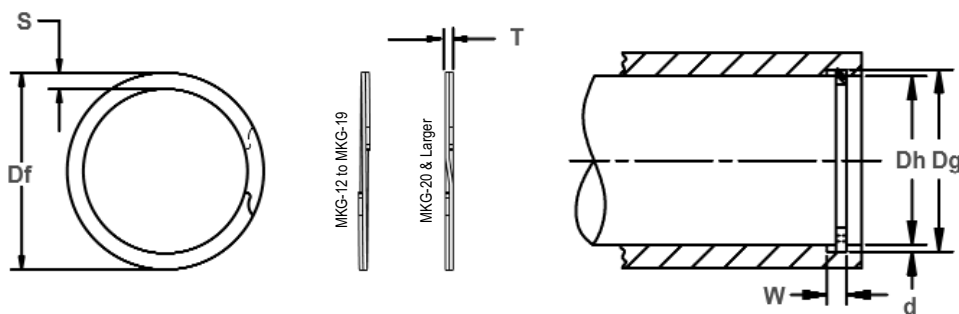

Free Diameter & Ring Measurements

Housing Diameter & Groove Dimensions

RING NO.	HOUSING DIAMETER (mm)	GROOVE SIZE				RING SIZE				SECTION		THRUST LOAD (N)	
		DIAMETER		WIDTH		FREE DIAMETER		THICKNESS		S	Tol.	RING Safety factor of 3	GROOVE Safety factor of 2
		Dg	Tol.	W	Tol.	Df	Tol.	T	Tol.				
MKG-65	65	69.15		2.55		69.63		2.29		5.72		128967	62641
MKG-68	68	72.35		2.55		72.86	+0.75	2.29		5.72		134919	71755
MKG-70	70	74.55		2.55		75.06	-0.00	2.29		5.72		138887	79264
MKG-72	72	76.65		2.55		77.18		2.29		5.72		142855	85617
MKG-75	75	79.85		2.55		80.40		2.29		5.72		148808	96681
MKG-78	78	82.95		2.95		83.53		2.72		7.14		183820	91487
MKG-80	80	85.15		2.95		85.74		2.72		7.14		188533	99943
MKG-82	82	87.35	+0.15	2.95		87.96		2.72		7.14		193246	109065
MKG-85	85	90.55	-0.15	2.95		91.18		2.72		7.14		200316	121272
MKG-88	88	93.75		2.95		94.41		2.72		7.14		207386	134554
MKG-90	90	95.85		2.95	+0.20	96.51		2.72	+0.08	7.14		212100	142716
MKG-92	92	97.95		2.95	-0.00	98.64		2.72	-0.08	7.14		216813	151766
MKG-95	95	101.15		2.95		101.86	+0.90	2.72		7.92		223883	168598
MKG-98	98	104.35		2.95		105.09	-0.00	2.72		7.92		230953	185160
MKG-100	100	106.50		2.95		107.29		2.72		7.92		235666	197997
MKG-102	102	108.60		2.95		109.42		2.72		7.92		240380	209267
MKG-105	105	111.70		2.95		112.52		2.72		7.92		247450	224146
MKG-108	108	114.80		2.95		115.64		2.72		7.92		254520	240221
MKG-110	110	116.90		2.95		117.77		2.72		7.92		259233	253044
MKG-115	115	122.10		2.95		123.00		2.72		7.92		271016	281888
MKG-120	120	127.20	+0.20	2.95	-0.20	128.14		2.72		7.92		282799	298287
MKG-125	125	132.30	-0.20	2.95		133.28		2.72		7.92		294583	315031
MKG-130	130	137.40		2.95		138.40		2.72		7.92		306366	332121
MKG-135	135	142.50		3.40		143.53		3.12		8.89	+0.10	364936	349555
MKG-140	140	146.70		3.40		148.64	+1.25	3.12	+0.10	8.89	-0.20	378452	367335
MKG-145	145	152.70		3.40		153.79	-0.00	3.12	-0.10	8.89		391968	385460
MKG-150	150	157.80		3.40		158.93		3.12		8.89		405485	403930
MKG-155	155	162.90		3.40		164.05		3.12		8.89		419001	422746
MKG-160	160	168.00		4.25		169.18		3.78		9.65		524011	429949
MKG-165	165	173.15		4.25		174.42	+1.40	3.78		9.65		540386	464261
MKG-170	170	178.25		4.25		179.55	-0.00	3.78		9.65		556761	484199
MKG-175	175	183.45		4.25	+0.25	184.78		3.78		9.65		573137	510523
MKG-180	180	188.65		4.25	-0.00	190.01		3.78		9.65		589512	537538
MKG-185	185	193.85		5.10		195.25		4.55	+0.13	10.62		729309	530579
MKG-190	190	199.05	+0.25	5.10		200.50		4.55	-0.13	10.62		749020	572409
MKG-200	200	209.25	-0.25	5.10		210.76		4.55		10.62		788442	638693
MKG-210	210	219.65		5.10		221.22	+1.80	4.55		10.62		827864	699628
MKG-220	220	230.25		5.10		231.91	-0.00	4.55		10.62		867286	778515
MKG-230	230	240.85		5.10		242.59		4.55		10.62		906709	861546
MKG-240	240	251.25		5.10		253.06		4.55		10.62		946131	932147
MKG-250	250	261.65		5.10		263.12		4.55		10.62		985553	1005511

MCG Spiral Shaft Rings

External, Heavy Duty, Metric

The rigors of the toughest applications are easily handled by this external series. Its large size, and ease of application and removal, transfers into an assurance of quality for demanding uses.

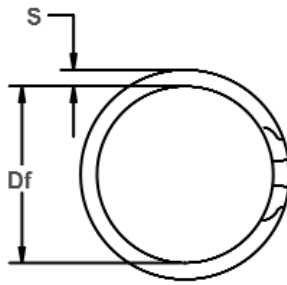

Free Diameter & Ring Measurements

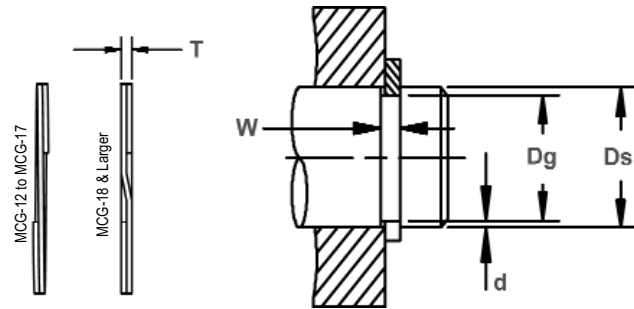

Shaft Diameter & Groove Dimensions

RING NO.	SHAFT DIAMETER (mm)	GROOVE SIZE				RING SIZE						THRUST LOAD (N)	
		DIAMETER		WIDTH		FREE DIAMETER		THICKNESS		SECTION		RING Safety factor of 3	GROOVE Safety factor of 2
		Ds	Dg Tol.	W Tol.		Df Tol.		T Tol.		S Tol.			
MCG-12	12	11.29		0.70		11.18		0.60		1.14		7954	2461
MCG-13	13	12.24	+0.06	1.00		12.13		0.89		1.27		11528	1930
MCG-14	14	13.19	-0.06	1.00		13.06		0.89		1.27		12415	2384
MCG-15	15	14.09		1.00		13.98		0.89		1.27		13302	3181
MCG-16	16	15.03		1.00		14.90		0.89		1.40		14188	3811
MCG-17	17	16.03		1.00		15.82		0.89		1.40		15075	4107
MCG-18	18	16.93		1.20		16.80		1.07		1.65		19190	4561
MCG-19	19	17.88		1.20	+0.08	17.73		1.07		1.65		20256	5309
MCG-20	20	18.78	+0.07	1.20	-0.00	18.62		1.07		1.65		21323	6427
MCG-21	21	19.73	-0.07	1.20		19.57		1.07		1.65		22389	7470
MCG-22	22	20.63		1.20		20.45	+0.00	1.07	+0.05	1.91	+0.08	23455	8686
MCG-23	23	21.58		1.20		21.39	-0.33	1.07	-0.05	1.91	-0.13	24521	9906
MCG-24	24	22.53		1.20		22.35		1.07		1.91		25587	11366
MCG-25	25	23.43		1.20		23.25		1.07		2.16		26653	13132
MCG-26	26	24.43		1.20		24.21		1.07		2.16		27719	14085
MCG-27	27	25.35		1.40		25.04		1.27		2.62		31195	10968
MCG-28	28	26.30		1.40		26.00		1.27		2.62		32350	12439
MCG-29	29	27.27		1.40		26.95		1.27		2.62		33506	13626
MCG-30	30	28.25	+0.10	1.40	+0.10	27.92		1.27		2.62		34661	14898
MCG-31	31	29.17	-0.10	1.40	-0.00	28.84		1.27		2.62		35817	16835
MCG-32	32	30.10		1.40		29.77		1.27		2.62		36972	18840
MCG-34	34	31.90		1.40		31.54		1.27		3.00		39283	23123
MCG-35	35	32.80		1.40		32.44		1.27		3.00		40438	25932
MCG-36	36	33.75		1.40		33.40		1.27		3.00		41593	27964
MCG-37	37	34.67	+0.15	1.40		34.24		1.27		3.00		42749	29763
MCG-38	38	35.65	-0.15	1.40		35.18		1.27		3.00		43904	30830

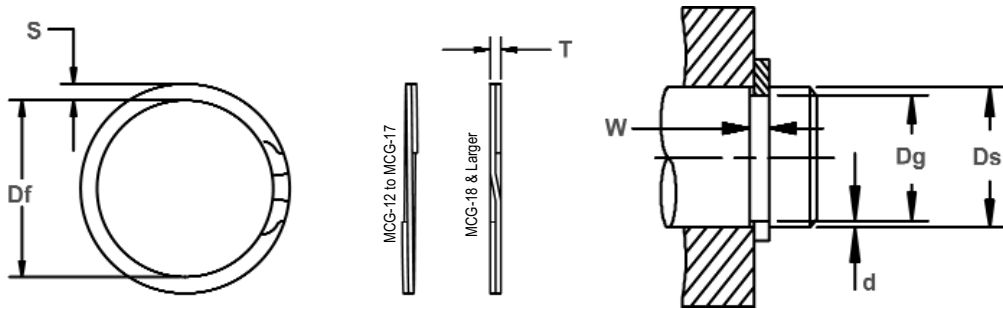

Free Diameter & Ring Measurements

Shaft Diameter & Groove Dimensions

RING NO.	SHAFT DIAMETER (mm)	GROOVE SIZE				RING SIZE						THRUST LOAD (N)	
		DIAMETER		WIDTH		FREE DIAMETER		THICKNESS		SECTION		RING Safety factor of 3	GROOVE Safety factor of 2
		Dg	Tol.	W	Tol.	Df	Tol.	T	Tol.	S	Tol.		
MCG-40	40	37.55		1.75		37.15		1.57		3.25		57132	30470
MCG-42	42	39.45		1.75		39.02		1.57		3.25		59988	35208
MCG-45	45	42.25		1.75	+0.10	41.77	+0.00	1.57		3.25	+0.08	64273	42723
MCG-46	46	43.15	+0.15	1.75	-0.00	42.67	-0.51	1.57		3.25	-0.13	65701	45261
MCG-47	47	44.31	-0.15	1.75		43.81		1.57		4.01		67130	43649
MCG-48	48	45.05		1.75		44.48		1.57		4.01		68558	48886
MCG-50	50	47.05		1.75		46.69		1.57		4.01		71415	50923
MCG-52	52	48.95		2.15		48.60		1.98		4.27		93667	53451
MCG-54	54	50.85		2.15		50.52		1.98		4.27		97270	58725
MCG-55	55	51.65		2.15		51.26		1.98		4.27		99071	63610
MCG-57	57	53.60		2.15		53.17	+0.00	1.98		4.27		102673	66907
MCG-58	58	54.50		2.15		54.08	-0.64	1.98	+0.08	4.27		104475	70084
MCG-60	60	56.50		2.15		56.05		1.98	-0.08	5.08		108077	72500
MCG-62	62	58.40		2.15		57.99		1.98		5.08		111680	77057
MCG-65	65	61.40		2.15		60.92		1.98		5.08		117084	80786
MCG-68	68	64.30		2.15	+0.13	63.80		1.98		5.08	+0.10	122488	86862
MCG-70	70	66.20		2.55	-0.00	65.70		2.29		5.72	-0.15	138887	91834
MCG-72	72	68.10	+0.20	2.55		67.57		2.29		5.72		142855	96943
MCG-75	75	71.00	-0.20	2.55		70.47	+0.00	2.29		5.72		148808	103572
MCG-78	78	73.80		2.55		73.25	-0.76	2.29		5.72		154760	113101
MCG-80	80	75.70		2.55		75.12		2.29		5.72		158728	118762
MCG-82	82	77.60		2.55		77.00		2.29		5.72		162696	124562
MCG-85	85	80.40		2.55		79.79		2.29		5.72		168649	134989
MCG-88	88	83.30		2.95		82.67		2.72		6.86		207386	142791
MCG-90	90	85.20		2.95		84.54	+0.00	2.72		6.86		212110	149144
MCG-95	95	90.00		2.95		89.32	-0.89	2.72		6.86		223883	163989
MCG-100	100	94.80		2.95		94.09		2.72		6.86		235666	179525



MKA Spiral Housing Rings

Internal, Aerospace, Metric

Dimensions Conform to Metric Aerospace

Specification MA 4017.

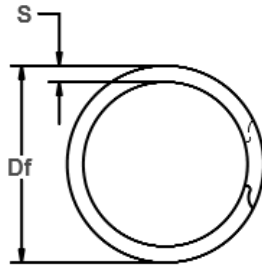

Free Diameter & Ring Measurements

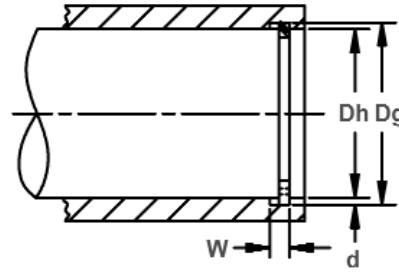
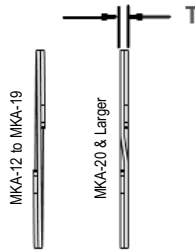

Housing Diameter & Groove Dimensions

RING NO.	HOUSING DIAMETER (mm)	GROOVE SIZE				RING SIZE				THRUST LOAD (N)			
		DIAMETER		WIDTH		FREE DIAMETER		THICKNESS		SECTION	RING Safety factor of 3	GROOVE Safety factor of 2	
		Dh	Dg	Tol.	W	Tol.	Df	Tol.	T				Tol.
MKA-12	12.00	12.70	±0.05	0.70	+0.08 -0.00	12.89	+0.35 -0.00	0.60	±0.05	1.14	±0.10	7,950	2,050
MKA-13	13.00	13.75		1.00		13.95		0.89		1.14		12,110	2,410
MKA-14	14.00	14.85		1.00		15.07		0.89		1.40		13,040	2,930
MKA-15	15.00	15.90		1.00		16.14		0.89		1.40		13,970	3,290
MKA-16	16.00	16.95		1.00		17.15		0.89		1.40		14,900	3,740
MKA-17	17.00	18.05		1.00		18.32		0.89		1.65		15,830	4,390
MKA-18	18.00	19.10		1.00		19.39		0.89		1.65		16,760	4,820
MKA-19	19.00	20.17		1.00		20.48		0.89		1.65		17,690	5,460
MKA-20	20.00	21.22		1.00		21.51		0.89		1.91		18,620	5,940
MKA-21	21.00	22.27	1.00	22.56	0.89	1.91	19,550	6,550					
MKA-22	22.00	23.37	±0.075	1.20	+0.35 -0.00	23.65	+0.51 -0.00	1.07	±0.075	1.91	±0.10	24,630	7,390
MKA-23	23.00	24.42		1.20		24.69		1.07		2.16		25,750	7,950
MKA-24	24.00	25.47		1.20		25.73		1.07		2.16		26,870	8,650
MKA-25	25.00	26.67		1.20		27.03		1.07		2.16		27,990	10,230
MKA-26	26.00	27.77		1.20		28.07		1.07		2.16		29,110	11,270
MKA-27	27.00	28.87		1.40		29.11		1.27		2.64		31,170	12,360
MKA-28	28.00	29.87		1.40		30.10		1.27		2.64		32,330	12,820
MKA-29	29.00	30.95	1.40	31.21	1.27	2.64	33,480	13,840					
MKA-30	30.00	32.00	1.40	32.28	1.27	2.64	34,640	14,610					
MKA-31	31.00	33.05	1.40	33.32	1.27	2.64	35,790	15,550					
MKA-32	32.00	34.00	1.40	34.23	1.27	2.64	36,950	15,880					
MKA-34	34.00	36.20	1.40	36.46	1.27	3.00	39,260	18,210					
MKA-35	35.00	37.30	1.40	37.55	1.27	3.00	40,410	19,600					
MKA-36	36.00	38.40	1.40	38.68	1.27	3.00	41,560	21,040					
MKA-37	37.00	39.40	1.40	39.60	1.27	3.00	42,720	21,620					
MKA-38	38.00	40.50	1.40	40.77	1.27	3.00	43,870	23,130					
MKA-40	40.00	42.50	1.75	42.91	1.57	3.25	57,090	24,350					
MKA-42	42.00	44.60	1.75	45.01	1.57	3.25	59,950	26,590					
MKA-45	45.00	47.70	1.75	48.13	1.57	3.25	64,230	29,590					
MKA-46	46.00	48.80	1.75	49.28	1.57	3.25	65,660	31,370					
MKA-47	47.00	49.90	1.75	50.32	1.57	4.01	67,080	33,190					
MKA-48	48.00	51.00	1.75	51.46	1.57	4.01	68,510	35,070					
MKA-50	50.00	53.20	1.75	53.66	1.57	4.01	71,370	38,960					
MKA-52	52.00	53.79	±0.125	1.42	+0.50 -0.00	54.30	+0.63 -0.00	1.25	±0.08	3.25	±0.10	59,090	22,790
MKA-53	53.00	54.79		1.42		55.32		1.25		3.25		60,230	23,230
MKA-55	55.00	56.85	1.42	57.38	1.25	3.51	62,500	24,910					
MKA-56	56.00	57.85	1.42	58.40	1.25	3.51	63,640	25,360					
MKA-58	58.00	59.85	1.42	60.43	1.25	3.51	65,910	26,270					
MKA-59	59.00	60.93	1.42	61.54	1.25	3.51	67,050	27,870					
MKA-60	60.00	61.99	±0.15	1.42	+0.63 -0.00	62.57	+0.63 -0.00	1.25	±0.08	3.51	±0.10	68,180	29,220
MKA-61	61.00	63.09		1.42		63.65		1.25		3.81		69,320	31,190
MKA-62	62.00	64.09		1.42		64.70		1.25		3.81		70,460	31,700
MKA-63	63.00	65.09		1.42		65.70		1.25		3.81		71,590	32,220
MKA-64	64.00	66.19		1.42		66.77		1.25		3.81		72,730	34,290
MKA-65	65.00	67.19		1.42		67.82		1.25		3.81		73,870	34,820
MKA-66	66.00	68.19		1.42		68.80		1.25		3.81		75,000	35,360
MKA-67	67.00	69.25	1.42	69.90	1.25	3.81	76,140	36,870					



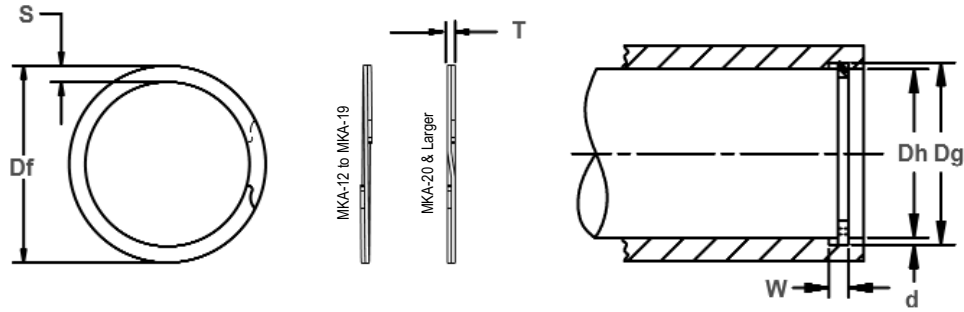

Free Diameter & Ring Measurements

Housing Diameter & Groove Dimensions

RING NO.	HOUSING DIAMETER (mm)	GROOVE SIZE				FREE DIAMETER		RING SIZE THICKNESS		SECTION		THRUST LOAD (N)	
		Dh	Dg	Tol.	W	Tol.	Df	Tol.	T	Tol.	S	Tol.	RING Safety factor of 3
MKA-68	68.00	70.29		1.42		70.94		1.25		4.01		77,270	38,090
MKA-69	69.00	71.29		1.42		71.94		1.25		4.01	±0.10	78,410	38,650
MKA-70	70.00	72.29		1.42	+0.10	72.94	+0.63	1.25		4.01		79,550	39,210
MKA-71	71.00	73.29		1.42	-0.00	73.99	-0.00	1.25		4.01		80,680	39,770
MKA-72	72.00	74.39		1.42		75.04		1.25		4.27		81,510	40,910
MKA-75	75.00	77.39		1.42		78.07		1.25		4.27		85,230	43,830
MKA-78	78.00	80.45		1.73		81.21		1.55		4.27		109,910	46,730
MKA-80	80.00	82.49		1.73		83.22		1.55		4.52		112,730	48,700
MKA-82	82.00	84.55		1.73		85.28		1.55		4.52		115,550	51,120
MKA-85	85.00	87.65		1.73		88.38		1.55	±0.08	4.78		119,780	55,060
MKA-88	88.00	90.69		1.73		91.45	+0.76	1.55		4.78		124,000	57,860
MKA-90	90.00	92.79	±0.15	1.73		93.58	-0.00	1.55		5.03		126,820	61,370
MKA-92	92.00	94.85		1.73		95.66		1.55		5.03		129,640	64,070
MKA-95	95.00	97.85		1.73		98.69		1.55		5.03		133,870	66,160
MKA-98	98.00	100.99		1.73	+0.13	101.83		1.55		5.28	±0.13	138,090	71,590
MKA-100	100.00	102.99		1.73	-0.00	103.83		1.55		5.28		140,910	73,050
MKA-102	102.00	105.15		1.73		106.00		1.55		5.54		143,730	78,490
MKA-105	105.00	108.15		1.73		109.00		1.55		5.54		147,960	80,800
MKA-108	108.00	111.31		1.73		112.22		1.55		5.79		152,190	87,310
MKA-110	110.00	113.31		1.73		114.25		1.55		5.79		155,000	92,140
MKA-112	112.00	115.45		1.73		116.44	+0.90	1.55		6.05		157,820	94,370
MKA-115	115.00	118.45		1.73		119.44	-0.00	1.55		6.05		162,050	96,890
MKA-120	120.00	123.55		2.00		124.54		1.83		6.35		199,640	104,030
MKA-125	125.00	128.55		2.00		129.59		1.83		6.35		207,960	108,360
MKA-130	130.00	133.65		2.00		134.71		1.83		6.35		216,280	115,860
MKA-135	135.00	138.62		2.00		139.74		1.83		6.35		224,600	119,000
MKA-140	140.00	143.72	±0.18	2.00		144.87	+1.14	1.83		6.35		232,920	126,820
MKA-145	145.00	148.82		2.00		150.04	-0.00	1.83		6.35		241,230	134,880
MKA-150	150.00	153.82		2.00		155.07		1.83		6.35		249,550	139,530
MKA-155	155.00	159.40		2.40		160.72		2.18		7.92		307,190	166,080
MKA-160	160.00	164.40		2.40		165.74		2.18		7.92		317,100	171,433
MKA-165	165.00	169.40		2.40		170.77	+1.40	2.18		7.92		327,010	176,790
MKA-170	170.00	174.60		2.40		176.05	-0.00	2.18		7.92		336,920	190,430
MKA-175	175.00	179.60		2.40		181.05		2.18	±0.10	7.92		346,830	196,030
MKA-180	180.00	184.88		2.40		186.38		2.18		7.92		356,740	213,900
MKA-185	185.00	189.88		2.40		191.10		2.18		7.92		366,650	219,840
MKA-190	190.00	194.88	±0.20	2.40	+0.20	196.45		2.18		7.92		376,560	225,790
MKA-195	195.00	200.14		2.40	-0.00	201.74		2.18		7.92	±0.15	386,460	244,070
MKA-200	200.00	205.14		2.40		206.76		2.18		7.92		396,370	250,330
MKA-210	210.00	215.40		2.40		217.10		2.18		9.53		416,490	276,140
MKA-220	220.00	225.64		2.40		227.40	+1.65	2.18		9.53		436,010	257,150
MKA-230	230.00	235.90		2.40		237.73	-0.00	2.18		9.53		455,830	330,450
MKA-240	240.00	245.90		2.40		247.80		2.18		9.53		475,650	344,810
MKA-250	250.00	256.16		2.40		258.10		2.18		9.53		495,470	375,010
MKA-260	260.00	266.40		2.40		268.43		2.18		9.53		515,290	405,210
MKA-270	270.00	276.40		2.40		278.50		2.18		9.53		535,100	420,790
MKA-280	280.00	286.66		2.40		288.82		2.18		9.53		554,920	454,100

ALL DIMENSIONS IN MILLIMETERS UNLESS OTHERWISE STATED.

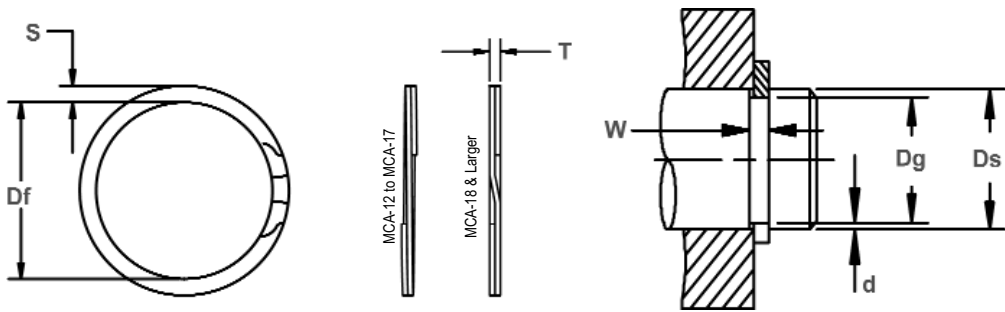

Free Diameter & Ring Measurements

Shaft Diameter & Groove Dimensions

RING NO.	SHAFT DIAMETER (mm)	GROOVE SIZE				RING SIZE						THRUST LOAD (N)	
		DIAMETER		WIDTH		FREE DIAMETER		THICKNESS		SECTION		RING Safety factor of 3	GROOVE Safety factor of 2
		Ds	Dg	Tol.	W	Tol.	Df	Tol.	T	Tol.	S		
MCA-12	12	11.29	±0.06	0.70		11.18		0.60		1.14		7,950	2,100
MCA-13	13	12.24		1.00		12.13		0.89		1.27		12,100	2,410
MCA-14	14	13.19		1.00		13.06		0.89		1.27		13,040	2,800
MCA-15	15	14.09	±0.075	1.00		13.98		0.89		1.27		13,970	3,360
MCA-16	16	15.02		1.00		14.90		0.89		1.40		14,900	3,820
MCA-17	17	16.02		1.00		15.82		0.89		1.40		15,830	4,060
MCA-18	18	16.92		1.20		16.80		1.07		1.65		20,150	4,730
MCA-19	19	17.87		1.20		17.73		1.07		1.65		21,270	5,270
MCA-20	20	18.77		1.20		18.62		1.07		1.65		22,390	6,040
MCA-21	21	19.72		1.20		19.57		1.07		1.65		23,510	6,550
MCA-22	22	20.62		1.20		20.45		1.07		1.91		24,630	7,390
MCA-23	23	21.57	±0.10	1.20		21.39	+0.00 -0.33	1.07	±0.05	1.91		25,750	8,070
MCA-24	24	22.52		1.20		22.35		1.07		1.91		26,870	8,650
MCA-25	25	23.42		1.20		23.25		1.07		2.16		27,990	9,620
MCA-26	26	24.42		1.20		24.21		1.07		2.16		29,110	10,000
MCA-27	27	25.35		1.40		25.04		1.27		2.64		31,170	10,910
MCA-28	28	26.30		1.40		26.00		1.27		2.64		32,330	11,590
MCA-29	29	27.27		1.40		26.95		1.27		2.64		33,480	12,290
MCA-30	30	28.25		1.40		27.92		1.27		2.64		34,640	12,860
MCA-31	31	29.17	±0.15	1.40		28.84		1.27		2.64	±0.10	35,790	13,890
MCA-32	32	30.09		1.40		29.77		1.27		2.64		36,950	14,960
MCA-34	34	31.90		1.40		31.54		1.27		3.00		39,260	17,390
MCA-35	35	32.80		1.40		32.44		1.27		3.00		40,410	18,750
MCA-36	36	33.75		1.40		33.40		1.27		3.00		41,560	19,810
MCA-37	37	34.67		1.40		34.24		1.27		3.00		42,720	21,080
MCA-38	38	35.66		1.40		35.18		1.27		3.00		43,870	21,650
MCA-40	40	37.55		1.75		37.15		1.57		3.25		57,090	23,960
MCA-42	42	39.45	±0.10 -0.00	1.75		39.02		1.57	±0.075	3.25		59,990	26,180
MCA-45	45	42.25		1.75		41.77		1.57		3.25		64,230	30,240
MCA-46	46	43.15		1.75		42.67		1.57		3.25		65,660	32,040
MCA-47	47	44.31		1.75		43.81		1.57		4.01		67,080	30,900
MCA-48	48	45.05		1.75		44.48		1.57		4.01		68,510	34,600
MCA-50	50	47.05		1.75		46.69		1.57		4.01		71,370	36,040
MCA-52	52	50.15		1.42		49.62		1.25		3.25		59,090	23,550
MCA-53	53	51.15		1.42		50.62		1.25		3.25		60,230	24,000
MCA-54	54	52.15	1.42	51.62	1.25	3.25	61,370	24,460					
MCA-55	55	53.15	1.42	52.62	1.25	3.51	62,500	24,910					
MCA-56	56	54.15	1.42	53.62	1.25	3.51	63,640	25,370					
MCA-58	58	56.01	±0.08	1.42		55.43	+0.00 -0.63	1.25	±0.08	3.51		65,910	28,250
MCA-59	59	57.01		1.42		56.43		1.25		3.51		67,050	28,730
MCA-60	60	58.01		1.42		57.43		1.25		3.51		68,180	29,220
MCA-61	61	58.91		1.42		58.36		1.25		3.51		69,320	31,190
MCA-62	62	59.91		1.42		59.30		1.25		3.76		70,460	31,710
MCA-63	63	60.91		1.42		60.30		1.25		3.76		71,590	32,220
MCA-64	64	61.91		1.42		61.25		1.25		3.76		72,730	32,730

ALL DIMENSIONS IN MILLIMETERS UNLESS OTHERWISE STATED.

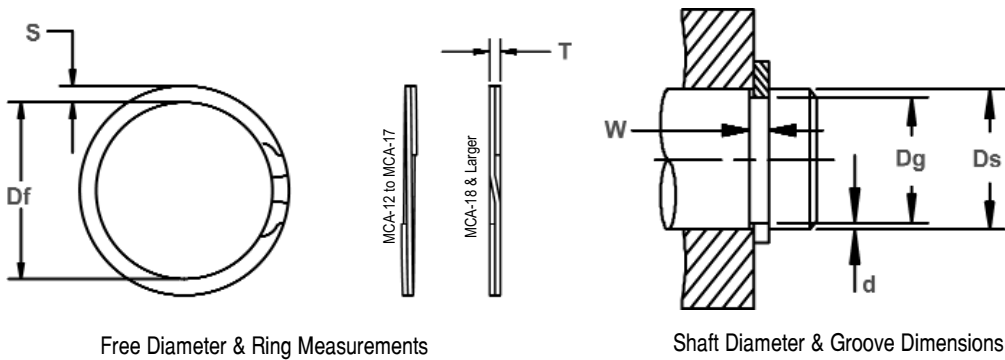

RING NO.	SHAFT DIAMETER (mm)	GROOVE SIZE				RING SIZE						THRUST LOAD (N)	
		DIAMETER		WIDTH		FREE DIAMETER		THICKNESS		SECTION		RING Safety factor of 3	GROOVE Safety factor of 2
		Ds	Dg	Tol.	W	Tol.	Df	Tol.	T	Tol.	S		
MCA-65	65	62.81		1.42		62.20		1.25		3.76		73,870	34,820
MCA-66	66	63.79		1.42		63.16	+0.00	1.25		3.76		75,000	35,680
MCA-67	67	64.71		1.42		64.16	-0.63	1.25		3.76		76,140	37,530
MCA-68	68	65.71		1.42	+0.10	65.08		1.25		4.01	±0.10	77,270	38,090
MCA-69	69	66.71		1.42	-0.00	66.06		1.25		4.01		78,410	38,650
MCA-70	70	67.71		1.42		67.08		1.25		4.01		79,550	39,210
MCA-71	71	68.71		1.42		68.04		1.25		4.01		80,680	39,770
MCA-72	72	69.65		1.42		69.00		1.25		4.27		81,820	41,380
MCA-75	75	72.61		1.42		71.93		1.25		4.27		85,230	43,830
MCA-78	78	75.55	±0.15	1.73		74.84	+0.00	1.55	±0.08	4.27		109,910	46,730
MCA-80	80	77.51		1.73		76.80	-0.76	1.55		4.52		112,730	48,700
MCA-82	82	79.45		1.73		78.72		1.55		4.52		115,550	51,120
MCA-85	85	82.35		1.73		81.62		1.55		4.78		119,780	55,060
MCA-88	88	85.31		1.73		84.53		1.55		4.78		124,000	57,860
MCA-90	90	87.21		1.73		86.43		1.55		5.03		126,820	61,370
MCA-95	95	92.15		1.73		91.37		1.55		5.03	±0.13	133,870	66,160
MCA-100	100	97.01		1.73		96.10		1.55		5.28		140,910	73,050
MCA-105	105	101.85		1.73	+0.13	100.94		1.55		5.54		147,960	80,780
MCA-110	110	106.69		1.73	-0.00	105.75		1.55		5.79		155,000	88,930
MCA-115	115	111.55		1.73		110.59	+0.00	1.55		6.05		162,050	96,890
MCA-120	120	116.45		2.00		115.49	-1.00	1.83		6.35		199,640	104,030
MCA-125	125	121.45		2.00		120.44		1.83		6.35		207,960	108,360
MCA-130	130	126.35		2.00		125.34		1.83		6.35		216,280	115,860
MCA-135	135	131.27		2.00		130.20		1.83		6.35		224,600	122,950
MCA-140	140	136.25		2.00		135.14		1.83		6.35		232,920	128,190
MCA-145	145	141.17		2.00		140.00	+0.00	1.83		6.35		241,230	135,590
MCA-150	150	146.17		2.00		145.00	-1.30	1.83		6.35		249,550	140,260
MCA-155	155	150.60		2.40		149.33		2.18		7.92		307,190	166,080
MCA-160	160	155.60		2.40		154.31		2.18		7.92		317,100	171,430
MCA-165	165	160.60		2.40		159.23		2.18		7.92		327,010	176,790
MCA-170	170	165.40		2.40		164.00		2.18		7.92		336,920	190,430
MCA-175	175	170.40		2.40		169.00	+0.00	2.18		7.92		346,830	196,030
MCA-180	180	175.20	±0.175	2.40		173.78	-1.52	2.18	±0.10	7.92		356,740	210,400
MCA-185	185	180.20		2.40		178.70		2.18		7.92		366,650	216,240
MCA-190	190	185.20		2.40		183.70		2.18		7.92		376,560	220,080
MCA-195	195	190.00		2.40	+0.15	188.43		2.18		7.92	±0.15	386,460	237,420
MCA-200	200	195.00		2.40	-0.00	193.43		2.18		7.92		396,370	243,510
MCA-210	210	204.60		2.40		202.93		2.18		9.53		416,190	276,140
MCA-220	220	214.40		2.40		212.65		2.18		9.53		436,010	300,010
MCA-230	230	224.40		2.40		222.60	+0.00	2.18		9.53		455,830	313,640
MCA-240	240	234.20		2.40		232.32	-1.78	2.18		9.53		475,650	328,970
MCA-250	250	243.80		2.40		241.83		2.18		9.53		495,470	377,440
MCA-260	260	253.60		2.40		251.57		2.18		9.53		515,290	405,210
MCA-270	270	263.40		2.40		261.30		2.18		9.53		535,100	433,940
MCA-280	280	273.20		2.40		271.04		2.18		9.53		554,920	463,650

ALL DIMENSIONS IN MILLIMETERS UNLESS OTHERWISE STATED.



NKG TruWave™ Housing Ring

Internal, Spiral, Inch

The waves in this spiral ring compensate for accumulated tolerances.

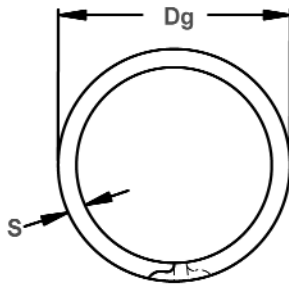

Free Diameter & Ring Measurements

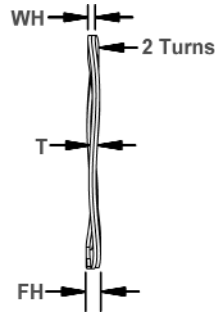

Shaft Diameter & Groove Dimensions

RING NO.	HOUSING DIAMETER	LOAD (lbs.) @ WORK HEIGHT	FREE HEIGHT (max.)	NUMBER OF WAVES	GROOVE SIZE		RING SIZE	
					DIAMETER	WIDTH	THICKNESS	SECTION
	Dh	WH	FH	Dg	W min.	T	S	
NKG-75	.750	25 @ .080	.114	3	.796	.119	.035	.065
NKG-87	.875	30 @ .085	.110	3	.931	.115	.042	.085
NKG-100	1.000	34 @ .085	.120	3	1.066	.125	.042	.085
NKG-112	1.125	38 @ .100	.125	3	1.197	.130	.050	.128
NKG-125	1.250	40 @ .100	.135	3	1.330	.140	.050	.128
NKG-137	1.375	45 @ .100	.125	4	1.461	.130	.050	.128
NKG-150	1.500	50 @ .100	.135	4	1.594	.140	.050	.128
NKG-162	1.625	55 @ .110	.135	4	1.725	.140	.062	.158
NKG-175	1.750	60 @ .110	.140	4	1.858	.145	.062	.158
NKG-187	1.875	63 @ .110	.141	4	1.989	.146	.062	.158
NKG-200	2.000	65 @ .110	.150	4	2.122	.155	.062	.158
NKG-212	2.125	70 @ .130	.170	4	2.251	.175	.078	.188
NKG-225	2.250	75 @ .130	.175	4	2.382	.180	.078	.188
NKG-237	2.375	80 @ .130	.180	4	2.517	.185	.078	.188
NKG-250	2.500	84 @ .130	.183	4	2.648	.188	.078	.188
NKG-262	2.625	88 @ .170	.220	4	2.781	.225	.093	.225
NKG-275	2.750	94 @ .170	.229	4	2.914	.234	.093	.225
NKG-287	2.875	97 @ .170	.225	4	3.051	.230	.093	.225
NKG-300	3.000	100 @ .170	.230	4	3.182	.235	.093	.225
NKG-312	3.125	103 @ .185	.250	4	3.315	.255	.111	.281
NKG-325	3.250	106 @ .185	.250	4	3.446	.255	.111	.281
NKG-350	3.500	115 @ .185	.245	4	3.710	.250	.111	.281
NKG-362	3.625	117 @ .185	.250	4	3.841	.250	.111	.281
NKG-375	3.750	121 @ .185	.255	4	3.974	.260	.111	.312
NKG-387	3.875	126 @ .185	.260	4	4.107	.265	.111	.312
NKG-400	4.000	130 @ .185	.255	4	4.240	.260	.111	.312
NKG-412	4.125	134 @ .185	.258	4	4.365	.263	.111	.312
NKG-425	4.250	140 @ .185	.264	4	4.490	.269	.111	.312
NKG-450	4.500	150 @ .185	.250	5	4.740	.255	.111	.312
NKG-475	4.750	160 @ .185	.252	5	4.995	.257	.111	.312
NKG-500	5.000	170 @ .185	.247	5	5.260	.252	.111	.312

NOTE: SIZES -312 THRU -500 ARE CRIMPED.

External, Spiral, Inch

The waves in this spiral ring compensate for accumulated tolerances.

NCG TruWave™ Shaft Ring

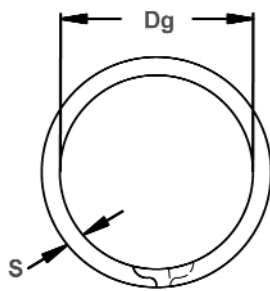

Free Diameter & Ring Measurements

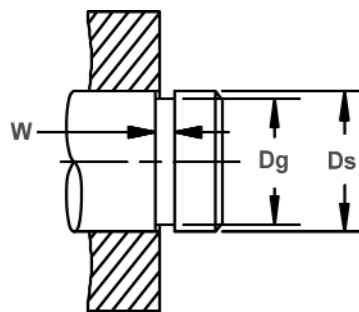
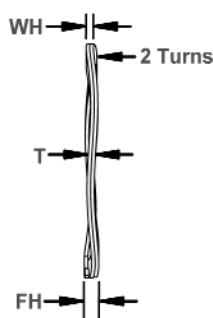

Shaft Diameter & Groove Dimensions

RING NO.	SHAFT DIAMETER	LOAD (lbs.) @ WORK HEIGHT	FREE HEIGHT (max.)	NUMBER OF WAVES	GROOVE SIZE		RING SIZE	
					DIAMETER	WIDTH	THICKNESS	SECTION
	Ds	WH	FH	Dg	W min	T	S	
NCG-75	.750	25 @ .085	.115	3	.704	.120	.042	.065
NCG-87	.875	30 @ .085	.131	3	.821	.136	.042	.075
NCG-100	1.000	34 @ .085	.129	3	.940	.134	.042	.085
NCG-112	1.125	38 @ .100	.137	3	1.059	.142	.050	.128
NCG-125	1.250	40 @ .100	.145	3	1.176	.150	.050	.128
NCG-137	1.375	45 @ .100	.130	4	1.291	.135	.050	.128
NCG-150	1.500	50 @ .100	.126	4	1.406	.131	.050	.128
NCG-162	1.625	55 @ .110	.138	4	1.529	.143	.062	.158
NCG-175	1.750	60 @ .110	.137	4	1.650	.142	.062	.158
NCG-187	1.875	63 @ .110	.140	4	1.769	.145	.062	.158
NCG-200	2.000	65 @ .110	.145	4	1.886	.150	.062	.158
NCG-212	2.125	70 @ .130	.170	4	2.003	.175	.078	.188
NCG-225	2.250	75 @ .130	.175	4	2.120	.180	.078	.188
NCG-237	2.375	80 @ .130	.175	4	2.239	.180	.078	.188
NCG-250	2.500	84 @ .130	.171	4	2.360	.176	.078	.188
NCG-262	2.625	88 @ .130	.181	4	2.481	.190	.078	.188
NCG-275	2.750	94 @ .170	.217	4	2.602	.222	.093	.225
NCG-287	2.875	97 @ .170	.217	4	2.721	.222	.093	.225
NCG-300	3.000	100 @ .170	.225	4	2.838	.230	.093	.225
NCG-312	3.125	103 @ .170	.230	4	2.957	.235	.093	.225
NCG-325	3.250	106 @ .170	.225	4	3.076	.230	.093	.225
NCG-350	3.500	115 @ .185	.245	4	3.316	.250	.111	.281
NCG-362	3.625	117 @ .185	.250	4	3.435	.255	.111	.281
NCG-375	3.750	121 @ .185	.258	4	3.552	.263	.111	.281
NCG-387	3.875	126 @ .185	.255	4	3.673	.260	.111	.281
NCG-400	4.000	130 @ .185	.268	4	3.792	.273	.111	.281
NCG-412	4.125	134 @ .185	.263	4	3.919	.268	.111	.281
NCG-425	4.250	140 @ .185	.248	5	4.065	.253	.111	.281
NCG-450	4.500	150 @ .185	.256	5	4.310	.261	.111	.281
NCG-475	4.750	160 @ .185	.253	5	4.550	.258	.111	.281
NCG-500	5.000	170 @ .185	.259	5	4.790	.264	.111	.281

NOTE: SIZES -275 THRU -500 ARE CRIMPED.





SST Wave Springs

Single Turn, Inch
 Ideal for short deflection applications with low to medium forces. Offered in a number of waves and material thicknesses. Designed for a wide range of bore and rod diameters.

Wave Spring Measurements

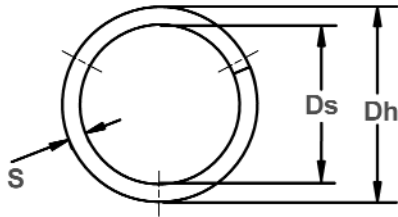

Overlap: Sizes -50 to -162
3 Waves

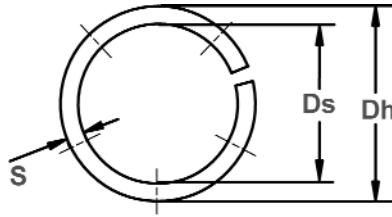

Gap: Sizes -175 & up
*Multiple Waves
(see table)

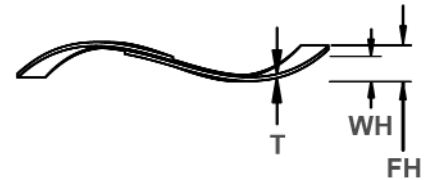

WAVE SPRING NO.	HOUSING DIAMETER	SHAFT DIAMETER CLEARANCE	LOAD (lb)	WORK HEIGHT	FREE HEIGHT Ref.	NO. OF WAVES*	THICKNESS	SECTION	SPRING RATE Ref. Lb/in.
	Dh	Ds		WH	FH		T	S	
SST-50	.500	.400	7	.050	.085	3	.008	.040	200
SST-62	.625	.480	10	.050	.095	3	.010	.058	222
SST-75	.750	.500	14	.062	.160	3	.010	.078	143
SST-87	.875	.620	16	.062	.130	3	.012	.094	235
SST-100	1.000	.780	18	.062	.160	3	.012	.094	184
SST-112	1.125	.840	20	.078	.130	3	.016	.133	385
SST-125	1.250	.960	22	.078	.150	3	.016	.133	306
SST-137	1.375	1.090	24	.078	.190	3	.016	.133	214
SST-150	1.500	1.170	26	.078	.170	3	.018	.143	283
SST-162	1.625	1.310	28	.078	.200	3	.018	.143	230
SST-175	1.750	1.440	30	.078	.140	4	.018	.143	484
SST-187	1.875	1.560	32	.078	.150	4	.018	.143	444
SST-200	2.000	1.680	34	.093	.140	4	.024	.150	723
SST-212	2.125	1.800	36	.093	.150	4	.024	.150	632
SST-225	2.250	1.930	38	.093	.170	4	.024	.150	494
SST-237	2.375	1.990	40	.093	.160	4	.024	.178	597
SST-250	2.500	2.120	42	.093	.170	4	.024	.178	545
SST-262	2.625	2.240	44	.093	.190	4	.024	.178	454
SST-275	2.750	2.340	46	.109	.170	4	.030	.188	754
SST-287	2.875	2.470	48	.109	.180	4	.030	.188	676
SST-300	3.000	2.590	50	.109	.190	4	.030	.188	617
SST-312	3.125	2.710	52	.109	.210	4	.030	.188	515
SST-325	3.250	2.750	54	.109	.200	4	.030	.233	593
SST-337	3.375	2.840	56	.109	.220	4	.030	.233	505
SST-350	3.500	3.000	58	.109	.230	4	.030	.233	479
SST-362	3.625	3.120	60	.109	.240	4	.030	.233	458
SST-375	3.750	3.250	62	.109	.260	4	.030	.233	411
SST-387	3.875	3.370	64	.109	.300	4	.030	.233	335
SST-400	4.000	3.500	66	.109	.190	5	.030	.233	815
SST-412	4.125	3.620	67	.109	.200	5	.030	.233	736
SST-425	4.250	3.740	69	.109	.210	5	.030	.233	683
SST-437	4.375	3.860	70	.109	.210	5	.030	.233	693
SST-450	4.500	3.990	72	.109	.230	5	.030	.233	595
SST-462	4.625	4.110	73	.125	.270	5	.030	.233	503
SST-475	4.750	4.240	75	.125	.310	5	.030	.233	405
SST-487	4.875	4.370	76	.125	.290	5	.030	.233	461

Wave Spring Measurements

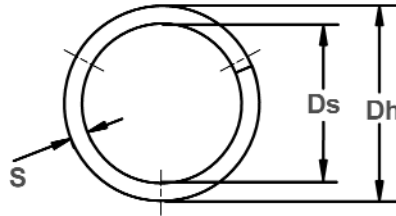

Overlap: Sizes -50 to -162
3 Waves

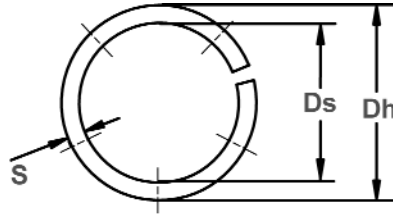

Gap: Sizes -175 & up
*Multiple Waves
(see table)

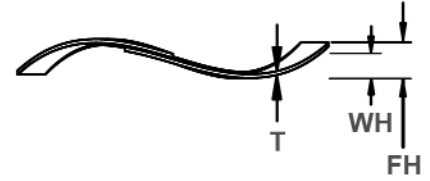

WAVE SPRING NO.	HOUSING DIAMETER	SHAFT DIAMETER CLEARANCE	LOAD (lb)	WORK HEIGHT	FREE HEIGHT Ref.	NO. OF WAVES*	THICKNESS	SECTION	SPRING RATE Ref. Lb/in.
	Dh	Ds		WH	FH		T	S	
SST-500	5.000	4.490	78	.125	.310	5	.030	.233	422
SST-512	5.125	4.610	80	.125	.340	5	.030	.233	372
SST-525	5.250	4.740	82	.125	.370	5	.030	.233	335
SST-537	5.375	4.860	84	.125	.380	5	.030	.233	329
SST-550	5.500	4.990	86	.125	.250	6	.030	.233	688
SST-562	5.625	5.110	88	.125	.270	6	.030	.233	607
SST-575	5.750	5.240	90	.125	.280	6	.030	.233	581
SST-587	5.875	5.360	92	.125	.300	6	.030	.233	526
SST-600	6.000	5.490	94	.125	.300	6	.030	.233	537
SST-612	6.125	5.610	96	.125	.310	6	.030	.233	519
SST-625	6.250	5.730	98	.125	.340	6	.030	.233	456
SST-637	6.375	5.860	100	.125	.350	6	.030	.233	444
SST-650	6.500	5.980	102	.125	.390	6	.030	.233	385
SST-675	6.750	6.230	104	.125	.420	6	.030	.233	353
SST-700	7.000	6.160	106	.156	.320	6	.032	.375	646
SST-725	7.250	6.440	108	.156	.350	6	.032	.375	557
SST-750	7.500	6.690	110	.156	.360	6	.032	.375	539
SST-775	7.750	6.940	114	.156	.380	6	.032	.375	509
SST-800	8.000	7.190	118	.156	.390	6	.032	.375	504
SST-825	8.250	7.440	122	.156	.430	6	.032	.375	445
SST-850	8.500	7.680	126	.156	.340	7	.032	.375	685
SST-875	8.750	7.930	130	.156	.340	7	.032	.375	707
SST-900	9.000	8.180	134	.156	.290	8	.032	.375	1,000
SST-950	9.500	8.680	142	.156	.240	9	.032	.375	1,690
SST-1000	10.000	9.170	150	.156	.290	9	.032	.375	1,119
SST-1050	10.500	9.670	158	.156	.310	9	.032	.375	1,026
SST-1100	11.000	10.170	166	.156	.350	9	.032	.375	856
SST-1150	11.500	10.660	174	.156	.360	9	.032	.375	853
SST-1200	12.000	11.160	182	.156	.440	9	.032	.375	641
SST-1250	12.500	11.660	190	.156	.350	10	.032	.375	979
SST-1300	13.000	12.160	198	.156	.410	10	.032	.375	780
SST-1350	13.500	12.650	206	.156	.430	10	.032	.375	752
SST-1400	14.000	13.150	214	.156	.300	12	.032	.375	1,486
SST-1450	14.500	13.650	221	.156	.320	12	.032	.375	1,348
SST-1500	15.000	14.130	230	.156	.350	12	.032	.375	1,186
SST-1550	15.500	14.640	239	.156	.310	13	.032	.375	1,552
SST-1600	16.000	15.140	248	.156	.340	13	.032	.375	1,348



NST Wave Springs

Single Turn, Narrow, Inch

Ideal for short deflection applications where space is minimal.

Wave Spring Measurements

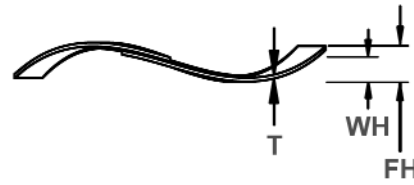
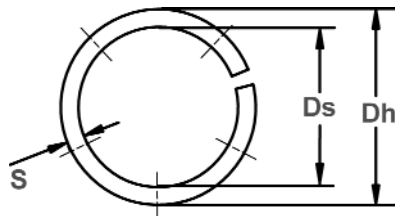

Gap Type
*Multiple Waves
(see table)

WAVE SPRING NO.	HOUSING DIAMETER	SHAFT DIAMETER CLEARANCE	LOAD (lb)	WORK HEIGHT	FREE HEIGHT Ref.	NO. OF WAVES*	THICKNESS	SECTION	SPRING RATE Ref. Lb/in.
	Dh	Ds		WH	FH		T	S	
NST-325	3.250	2.820	54	.109	.200	4	.03	.188	593
NST-337	3.375	2.940	56	.109	.220	4	.03	.188	505
NST-350	3.500	3.070	58	.109	.260	4	.03	.188	384
NST-362	3.625	3.190	60	.109	.270	4	.03	.188	373
NST-375	3.750	3.320	62	.109	.280	4	.03	.188	363
NST-387	3.875	3.440	64	.109	.310	4	.03	.188	318
NST-400	4.000	3.570	66	.109	.200	5	.03	.188	725
NST-412	4.125	3.690	67	.109	.200	5	.03	.188	736
NST-425	4.250	3.820	69	.109	.240	5	.03	.188	527
NST-437	4.375	3.940	70	.109	.210	5	.03	.188	693
NST-450	4.500	4.070	72	.109	.280	5	.03	.188	421
NST-462	4.625	4.190	73	.125	.270	5	.03	.188	503
NST-475	4.750	4.320	75	.125	.320	5	.03	.188	385
NST-487	4.875	4.440	76	.125	.320	5	.03	.188	390
NST-500	5.000	4.570	78	.125	.350	5	.03	.188	347
NST-512	5.125	4.690	80	.125	.350	5	.03	.188	356
NST-525	5.250	4.820	82	.125	.360	5	.03	.188	349
NST-537	5.375	4.940	84	.125	.440	5	.03	.188	267
NST-550	5.500	5.070	86	.125	.280	6	.03	.188	555
NST-562	5.625	5.190	88	.125	.290	6	.03	.188	533
NST-575	5.750	5.320	90	.125	.340	6	.03	.188	419
NST-587	5.875	5.440	92	.125	.340	6	.03	.188	428
NST-600	6.000	5.570	94	.125	.340	6	.03	.188	437
NST-612	6.125	5.690	96	.125	.280	7	.03	.188	619
NST-625	6.250	5.820	98	.125	.280	7	.03	.188	632
NST-637	6.375	5.940	100	.125	.300	7	.03	.188	571
NST-650	6.500	6.070	102	.125	.300	7	.03	.188	583
NST-675	6.750	6.320	104	.125	.300	7	.03	.188	594
NST-700	7.000	6.480	106	.156	.320	7	.03	.233	646
NST-725	7.250	6.730	108	.156	.330	7	.03	.233	621
NST-750	7.500	6.980	110	.156	.360	7	.03	.233	539
NST-775	7.750	7.230	114	.156	.380	7	.03	.233	509

Single Turn, Metric

Ideal for short deflection applications with low to medium forces. Offered in a number of waves and material thicknesses. Designed for a wide range of bore and rod diameters.

MST Wave Springs



Wave Spring Measurements

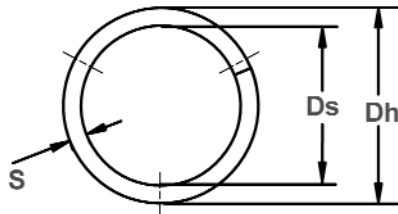

Overlap: Sizes -63 to -374
*Multiple Waves
(see table)

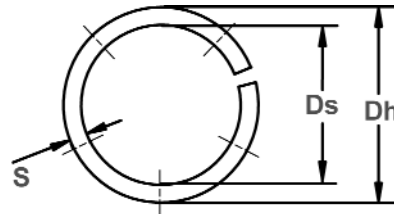

Gap: Sizes -394 & up
*Multiple Waves
(see table)

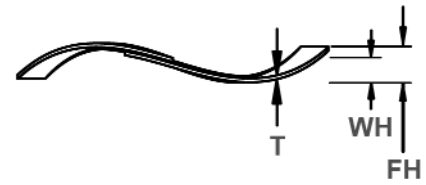

WAVE SPRING NO.	HOUSING DIAMETER		SHAFT DIAMETER CLEARANCE		LOAD (N)	WORK HEIGHT		FREE HEIGHT Ref.		NO. OF WAVES*	THICKNESS	SECTION	SPRING RATE Ref. N/mm
	Dh	Ds	WH	FH		T	S						
MST-63	16.0	11.28	44.5	1.57	2.29	3	.25	1.98	65				
MST-75	19.0	14.28	53.4	1.57	3.05	3	.25	1.98	35				
MST-87	22.0	16.46	62.3	1.57	2.79	3	.30	2.39	48				
MST-95	24.0	18.46	66.7	1.57	3.56	3	.30	2.39	35				
MST-102	26.0	18.22	71.2	1.98	2.54	3	.41	3.38	111				
MST-110	28.0	20.22	75.6	1.98	2.79	3	.41	3.38	85				
MST-118	30.0	22.22	84.5	1.98	3.30	3	.41	3.38	66				
MST-126	32.0	24.22	89.0	1.98	3.81	3	.41	3.38	52				
MST-138	35.0	27.22	97.9	1.98	4.57	3	.41	3.38	38				
MST-146	37.0	28.72	102.3	1.98	3.81	3	.46	3.63	58				
MST-158	40.0	31.72	111.2	1.98	5.08	3	.46	3.63	37				
MST-165	42.0	33.72	115.7	1.98	3.05	4	.46	3.63	99				
MST-185	47.0	38.72	129.0	1.98	3.81	4	.46	3.63	68				
MST-205	52.0	43.11	142.4	2.36	3.56	4	.61	3.81	121				
MST-217	55.0	46.11	151.3	2.36	3.81	4	.61	3.81	100				
MST-244	62.0	51.69	169.1	2.36	4.32	4	.61	4.52	85				
MST-268	68.0	57.17	186.9	2.77	4.32	4	.76	4.78	131				
MST-276	70.0	59.17	191.3	2.77	4.32	4	.76	4.78	119				
MST-284	72.0	61.17	195.8	2.77	4.57	4	.76	4.78	108				
MST-295	75.0	64.17	204.7	2.77	5.08	4	.76	4.78	94				
MST-315	80.0	68.66	218.0	2.77	5.59	4	.76	4.78	76				
MST-335	85.0	71.38	231.4	2.77	5.59	4	.76	5.92	83				
MST-354	90.0	76.38	249.2	2.77	6.35	4	.76	5.92	68				
MST-374	95.0	81.38	262.5	2.77	7.37	4	.76	5.92	57				
MST-394	100.0	86.38	275.9	2.77	4.57	5	.76	5.92	157				
MST-413	105.0	91.38	289.2	2.77	5.08	5	.76	5.92	134				
MST-433	110.0	96.38	302.6	2.77	5.33	5	.76	5.92	115				
MST-453	115.0	101.38	315.9	3.18	6.35	5	.76	5.92	99				
MST-472	120.0	106.38	329.3	3.18	7.11	5	.76	5.92	86				
MST-492	125.0	111.38	342.6	3.18	7.62	5	.76	5.92	76				
MST-512	130.0	116.38	356.0	3.18	8.64	5	.76	5.92	67				
MST-532	135.0	121.38	369.3	3.18	9.40	5	.76	5.92	59				
MST-551	140.0	126.38	382.7	3.18	6.86	6	.76	5.92	108				
MST-571	145.0	131.38	396.0	3.18	7.37	6	.76	5.92	97				
MST-591	150.0	136.38	404.9	3.18	7.87	6	.76	5.92	87				
MST-630	160.0	146.38	440.5	3.18	9.40	6	.76	5.92	71				
MST-650	165.0	151.38	453.9	3.18	10.41	6	.76	5.92	64				
MST-669	170.0	156.38	467.2	3.18	11.18	6	.76	5.92	58				

ALL DIMENSIONS IN MILLIMETERS UNLESS OTHERWISE STATED.





MST Wave Springs

Single Turn, Metric
 Ideal for short deflection applications with low to medium forces. Offered in a number of waves and material thicknesses. Designed for a wide range of bore and rod diameters.

Wave Spring Measurements

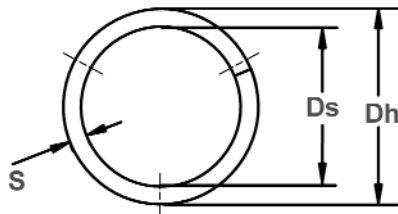

Overlap: Sizes -63 to -374
 *Multiple Waves
 (see table)

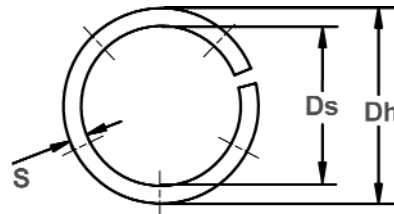

Gap: Sizes -394 & up
 *Multiple Waves
 (see table)

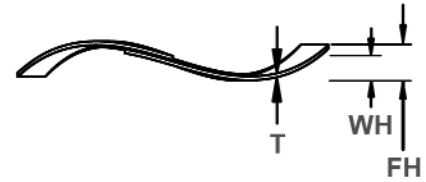

WAVE SPRING NO.	HOUSING DIAMETER		SHAFT DIAMETER CLEARANCE	LOAD (N)	WORK HEIGHT	FREE HEIGHT Ref.	NO. OF WAVES*	THICKNESS	SECTION	SPRING RATE Ref. N/mm
	Dh	Ds						T	S	
MST-689	175.0	154.16	480.6	3.96	8.13	6	.81	9.53	116	
MST-709	180.0	159.16	493.9	3.96	8.64	6	.81	9.53	105	
MST-728	185.0	164.16	507.3	3.96	9.14	6	.81	9.53	97	
MST-748	190.0	169.16	520.6	3.96	9.91	6	.81	9.53	88	
MST-787	200.0	179.16	547.3	3.96	7.11	7	.81	9.53	174	
MST-807	205.0	184.16	560.7	3.96	7.37	7	.81	9.53	161	
MST-827	210.0	189.16	578.5	3.96	7.87	7	.81	9.53	149	
MST-847	215.0	194.16	591.8	3.96	8.38	7	.81	9.53	138	
MST-866	220.0	199.16	605.2	3.96	8.64	7	.81	9.53	128	
MST-886	225.0	204.16	618.5	3.96	7.11	8	.81	9.53	203	
MST-906	230.0	209.16	631.9	3.96	6.10	9	.81	9.53	303	
MST-925	235.0	214.16	645.2	3.96	6.35	9	.81	9.53	283	
MST-945	240.0	219.16	658.6	3.96	6.35	9	.81	9.53	265	
MST-984	250.0	229.16	685.3	3.96	6.86	9	.81	9.53	232	
MST-1024	260.0	239.16	712.0	3.96	7.37	9	.81	9.53	205	
MST-1043	265.0	244.16	725.3	3.96	7.62	9	.81	9.53	193	
MST-1063	270.0	249.16	743.1	3.96	8.13	9	.81	9.53	182	
MST-1102	280.0	259.16	769.8	3.96	8.64	9	.81	9.53	162	
MST-1142	290.0	269.16	796.5	3.96	9.40	9	.81	9.53	144	
MST-1181	300.0	279.16	823.2	3.96	10.41	9	.81	9.53	129	
MST-1221	310.0	289.16	849.9	3.96	7.11	9	1.07	9.53	264	
MST-1260	320.0	299.16	876.6	3.96	7.62	9	1.07	9.53	239	
MST-1339	340.0	319.16	934.5	3.96	8.64	9	1.07	9.53	198	
MST-1378	350.0	329.16	961.1	3.96	9.40	9	1.07	9.53	180	
MST-1417	360.0	339.16	987.9	3.96	7.62	10	1.07	9.53	271	
MST-1457	370.0	349.16	1014.6	3.96	8.13	10	1.07	9.53	249	
MST-1496	380.0	359.16	1041.3	3.96	8.64	10	1.07	9.53	229	
MST-1535	390.0	369.16	1072.4	3.96	9.14	10	1.07	9.53	211	
MST-1575	400.0	379.16	1099.1	3.96	9.65	10	1.07	9.53	196	
MST-1614	410.0	382.82	1125.8	3.96	8.38	10	1.07	12.70	251	
MST-1654	420.0	392.82	1152.5	3.96	8.89	10	1.07	12.70	233	
MST-1693	430.0	402.82	1179.2	3.96	7.62	11	1.07	12.70	317	
MST-1732	440.0	412.82	1205.9	3.96	8.13	11	1.07	12.70	295	
MST-1811	460.0	432.82	1263.7	3.96	8.89	11	1.07	12.70	256	
MST-1890	480.0	452.82	1317.1	3.96	8.13	12	1.07	12.70	318	
MST-1969	500.0	472.82	1370.5	3.96	8.89	12	1.07	12.70	280	
MST-2126	540.0	512.82	1481.8	3.96	8.89	13	1.07	12.70	303	
MST-2284	580.0	552.82	1593.0	3.96	8.89	14	1.07	12.70	327	

ALL DIMENSIONS IN MILLIMETERS UNLESS OTHERWISE STATED.

Bearing Interchange Chart

This chart pairs metric single turn wave springs with the appropriate standard bearing number.



Wave Spring Measurements

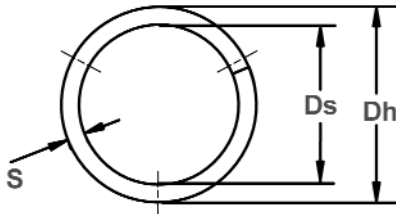

Overlap: Sizes -63 to -374
*Multiple Waves
(see table)

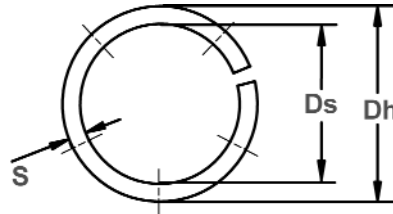

Gap: Sizes -394 & up
*Multiple Waves
(see table)

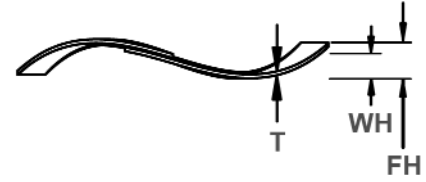

WAVE SPRING NO.	BEARING O.D. (mm)	BEARING NUMBERS						
		EXTRA SMALL	EXTREMELY LIGHT	EXTRA LIGHT	NARROW	LIGHT	MEDIUM	HEAVY
MST-63	16	34	-	-	-	-	-	-
MST-75	19	35,36	-	-	-	-	-	-
MST-87	22	37,38	00	-	-	-	-	-
MST-95	24	38KV	01	-	-	-	-	-
MST-102	26	39	-	100	-	-	-	-
MST-110	28	-	02	101	-	-	-	-
MST-118	30	-	03	-	-	200	-	-
MST-126	32	-	-	102	02	201	-	-
MST-138	35	-	-	103	-	202	300	-
MST-146	37	-	04	-	03	-	301	-
MST-158	40	-	-	-	-	203	-	-
MST-165	42	-	05	104	04	-	302	-
MST-185	47	-	06	105	-	204	303	-
MST-205	52	-	-	-	05	205	304	-
MST-217	55	-	07	106	-	-	-	-
MST-244	62	-	08	107	06	206	305	403
MST-268	68	-	09	108	-	-	-	-
MST-276	70	-	-	-	07	-	-	-
MST-284	72	-	10	-	-	207	306	404
MST-295	75	-	-	109	-	-	-	-
MST-315	80	-	11	110	08	208	307	405
MST-335	85	-	12	-	09	209	-	-
MST-354	90	-	13	111	10	210	308	406
MST-374	95	-	-	112	-	-	-	-
MST-394	100	-	14	113	11	211	309	407
MST-413	105	-	15	-	12	-	-	-
MST-433	110	-	16	114	-	212	310	408
MST-453	115	-	-	115	13	-	-	-
MST-472	120	-	17	-	14	213	311	409
MST-492	125	-	18	116	-	214	-	-
MST-512	130	-	19	117	15	215	312	410
MST-532	135	-	-	-	16	-	-	-
MST-551	140	-	20	118	-	216	313	411
MST-571	145	-	21	119	17	-	-	-
MST-591	150	-	22	120	18	217	314	412
MST-630	160	-	-	121	19	218	315	413
MST-650	165	-	24	-	20	-	-	-
MST-669	170	-	-	122	-	219	316	-

WAVE SPRING NO.	BEARING O.D. (mm)	BEARING NUMBERS						
		EXTRA SMALL	EXTREMELY LIGHT	EXTRA LIGHT	NARROW	LIGHT	MEDIUM	HEAVY
MST-689	175	-	-	-	22	-	-	-
MST-709	180	-	26	124	21	220	317	414
MST-728	185	-	-	-	22	-	-	-
MST-748	190	-	28	-	24	221	318	415
MST-787	200	-	-	126	-	222	319	416
MST-807	205	-	-	-	26	-	-	-
MST-827	210	-	30	128	-	-	-	417
MST-847	215	-	-	-	-	224	320	-
MST-866	220	-	32	-	28	-	-	-
MST-886	225	-	-	130	-	-	321	418
MST-906	230	-	34	-	-	226	-	-
MST-925	235	-	-	-	30	-	-	-
MST-945	240	-	-	132	-	-	322	-
MST-984	250	-	36	-	32	228	-	419
MST-1024	260	-	38	134	-	-	324	-
MST-1043	265	-	-	-	34	-	-	420
MST-1063	270	-	-	-	-	230	-	-
MST-1102	280	-	40	136	36	-	326	-
MST-1142	290	-	-	138	-	232	-	421
MST-1181	300	-	-	-	38	-	328	-
MST-1221	310	-	-	140	-	234	-	-
MST-1260	320	-	-	-	40	236	330	422
MST-1339	340	-	-	144	42	238	332	-
MST-1378	350	-	-	-	44	-	-	-
MST-1417	360	-	-	148	-	240	334	-
MST-1457	370	-	-	-	46	-	-	-
MST-1496	380	-	-	-	-	-	336	-
MST-1535	390	-	-	-	48	-	-	-
MST-1575	400	-	-	152	-	244	338	-
MST-1614	410	-	-	-	50	-	-	-
MST-1654	420	-	-	156	-	-	340	-
MST-1693	430	-	-	-	52	-	-	-
MST-1732	440	-	-	-	-	248	342	-
MST-1811	460	-	-	160	56	-	344	-
MST-1890	480	-	-	164	-	252	-	-
MST-1969	500	-	-	-	64	256	348	-
MST-2126	540	-	-	-	-	260	352	-
MST-2284	580	-	-	-	-	264	356	-

WSL, WSM, WSR Wave Springs

Multi Turn, Inch

Used for low force applications with large deflections:
More turns equals less force. Utilizes nearly half the space as
helical compression springs while producing the same force.

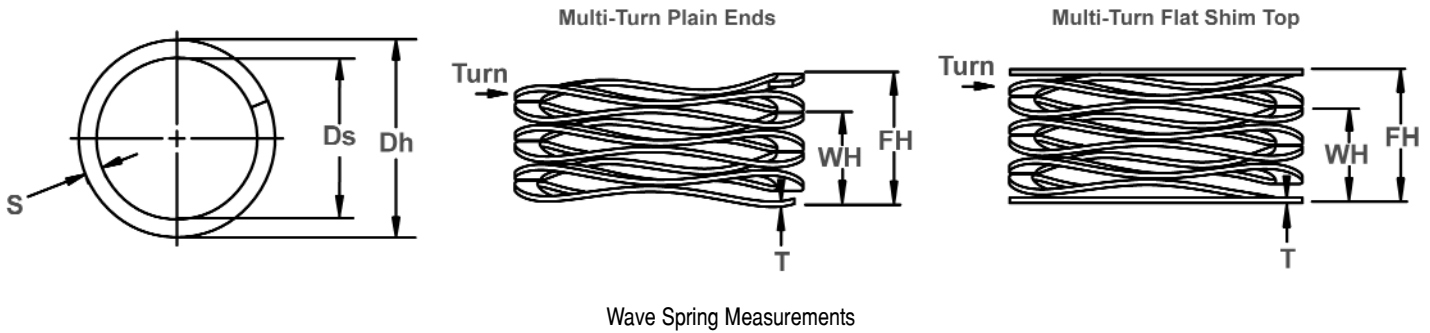

WAVE SPRING NO.	HOUSING DIAMETER			SHAFT DIAMETER CLEARANCE	LOAD (lbs.)	WORK HEIGHT	FREE HEIGHT Ref.	NUMBER OF WAVES	NUMBER OF TURNS	THICKNESS	SECTION	SPRING RATE Ref. Lb/in.
	Dh DEC	Dh FRAC	Dh mm									
WSL-37 A	.375	3/8	9.5	.250	4	.062	.150	2.5	3	.008	.032	45
WSL-37 B	.375	3/8	9.5	.250	4	.098	.200	2.5	4	.008	.032	39
WSL-37 C	.375	3/8	9.5	.250	4	.108	.250	2.5	5	.008	.032	28
WSL-37 D	.375	3/8	9.5	.250	4	.135	.300	2.5	6	.008	.032	24
WSL-37 E	.375	3/8	9.5	.250	4	.150	.350	2.5	7	.008	.032	20
WSL-37 F	.375	3/8	9.5	.250	4	.184	.400	2.5	8	.008	.032	19
WSL-37 G	.375	3/8	9.5	.250	4	.195	.450	2.5	9	.008	.032	16
WSL-37 H	.375	3/8	9.5	.250	4	.228	.500	2.5	10	.008	.032	15
WSL-37 I	.375	3/8	9.5	.250	4	.240	.550	2.5	11	.008	.032	13
WSM-37 A	.375	3/8	9.5	.250	7	.081	.150	2.5	3	.011	.032	101
WSM-37 B	.375	3/8	9.5	.250	7	.119	.200	2.5	4	.011	.032	86
WSM-37 C	.375	3/8	9.5	.250	7	.145	.250	2.5	5	.011	.032	67
WSM-37 D	.375	3/8	9.5	.250	7	.180	.300	2.5	6	.011	.032	58
WSM-37 E	.375	3/8	9.5	.250	7	.202	.350	2.5	7	.011	.032	47
WSM-37 F	.375	3/8	9.5	.250	7	.240	.400	2.5	8	.011	.032	44
WSM-37 G	.375	3/8	9.5	.250	7	.262	.450	2.5	9	.011	.032	37
WSM-37 H	.375	3/8	9.5	.250	7	.298	.500	2.5	10	.011	.032	35
WSM-37 I	.375	3/8	9.5	.250	7	.327	.550	2.5	11	.011	.032	31
WSL-43 A	.437	7/16	11.1	.281	4	.063	.165	2.5	3	.008	.040	39
WSL-43 B	.437	7/16	11.1	.281	4	.093	.220	2.5	4	.008	.040	31
WSL-43 C	.437	7/16	11.1	.281	4	.109	.275	2.5	5	.008	.040	24
WSL-43 D	.437	7/16	11.1	.281	4	.143	.330	2.5	6	.008	.040	21
WSL-43 E	.437	7/16	11.1	.281	4	.160	.385	2.5	7	.008	.040	18
WSL-43 F	.437	7/16	11.1	.281	4	.195	.440	2.5	8	.008	.040	16
WSL-43 G	.437	7/16	11.1	.281	4	.210	.495	2.5	9	.008	.040	14
WSL-43 H	.437	7/16	11.1	.281	4	.240	.550	2.5	10	.008	.040	13
WSL-43 I	.437	7/16	11.1	.281	4	.260	.605	2.5	11	.008	.040	12
WSM-43 A	.437	7/16	11.1	.281	8	.082	.165	2.5	3	.011	.046	96
WSM-43 B	.437	7/16	11.1	.281	8	.115	.220	2.5	4	.011	.046	76
WSM-43 C	.437	7/16	11.1	.281	8	.142	.275	2.5	5	.011	.046	60
WSM-43 D	.437	7/16	11.1	.281	8	.179	.330	2.5	6	.011	.046	53
WSM-43 E	.437	7/16	11.1	.281	8	.198	.385	2.5	7	.011	.046	43
WSM-43 F	.437	7/16	11.1	.281	8	.231	.440	2.5	8	.011	.046	38
WSM-43 G	.437	7/16	11.1	.281	8	.255	.495	2.5	9	.011	.046	33
WSM-43 H	.437	7/16	11.1	.281	8	.290	.550	2.5	10	.011	.046	31
WSM-43 I	.437	7/16	11.1	.281	8	.319	.605	2.5	11	.011	.046	28

PART NUMBERS SHOWN REFLECT MULTI-TURN WAVE SPRINGS WITH PLAIN ENDS.

THE LETTERS SHOWN AFTER THE PART NUMBERS REPRESENT THE NUMBER OF TURNS. WHEN ORDERING, PARTS SHOULD BE PRESENTED WITH THE PART NUMBER, FOLLOWED BY THE MATERIAL, AND THEN THE NUMBER OF TURNS (i.e. WSL-37ST A, WSM-50ST B, WSR-75ST C, ETC.)

FOR FLAT SHIM TOP WAVE SPRINGS, ADD AN 'F' TO THE END OF THE PART NUMBER (i.e. WSL-37ST AF, WSM-50ST BF, WSR-75ST CF, ETC.)

MATERIAL CODES: ST = CARBON STEEL. SQ = 17-7 PH/C STAINLESS STEEL. SPECIAL ALLOYS AVAILABLE UPON REQUEST.

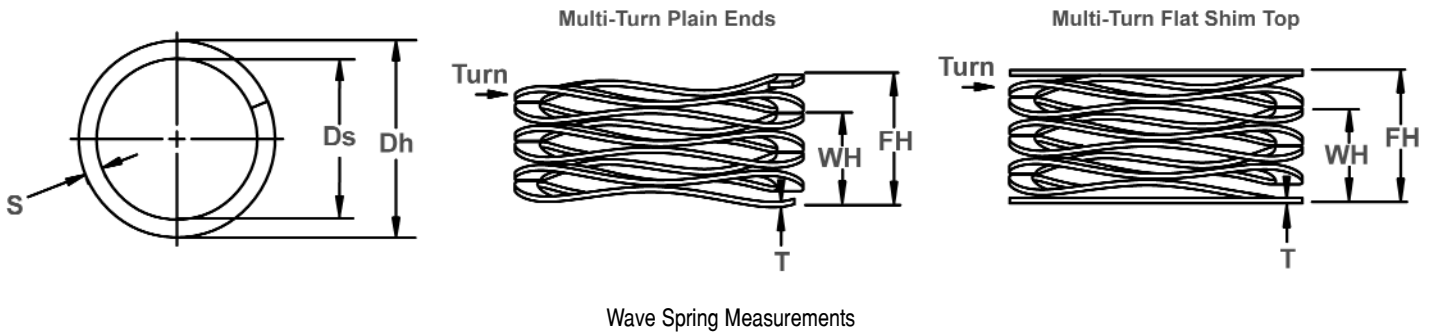

WAVE SPRING NO.	HOUSING DIAMETER			SHAFT DIAMETER CLEARANCE	LOAD (lbs.)	WORK HEIGHT	FREE HEIGHT Ref.	NUMBER OF WAVES	NUMBER OF TURNS	THICKNESS	SECTION	SPRING RATE Ref. Lb/in.
	Dh DEC	Dh FRAC	Dh mm									
WSL-50 A	.500	1/2	12.7	.312	5	.062	.180	2.5	3	.008	.056	42
WSL-50 B	.500	1/2	12.7	.312	5	.090	.240	2.5	4	.008	.056	33
WSL-50 C	.500	1/2	12.7	.312	5	.107	.300	2.5	5	.008	.056	26
WSL-50 D	.500	1/2	12.7	.312	5	.136	.360	2.5	6	.008	.056	22
WSL-50 E	.500	1/2	12.7	.312	5	.150	.420	2.5	7	.008	.056	19
WSL-50 F	.500	1/2	12.7	.312	5	.180	.480	2.5	8	.008	.056	17
WSL-50 G	.500	1/2	12.7	.312	5	.195	.540	2.5	9	.008	.056	14
WSL-50 H	.500	1/2	12.7	.312	5	.220	.600	2.5	10	.008	.056	13
WSL-50 I	.500	1/2	12.7	.312	5	.240	.660	2.5	11	.008	.056	12
WSM-50 A	.500	1/2	12.7	.312	10	.065	.180	2.5	3	.010	.058	87
WSM-50 B	.500	1/2	12.7	.312	10	.092	.240	2.5	4	.010	.058	68
WSM-50 C	.500	1/2	12.7	.312	10	.114	.300	2.5	5	.010	.058	54
WSM-50 D	.500	1/2	12.7	.312	10	.147	.360	2.5	6	.010	.058	47
WSM-50 E	.500	1/2	12.7	.312	10	.162	.420	2.5	7	.010	.058	39
WSM-50 F	.500	1/2	12.7	.312	10	.196	.480	2.5	8	.010	.058	35
WSM-50 G	.500	1/2	12.7	.312	10	.207	.540	2.5	9	.010	.058	30
WSM-50 H	.500	1/2	12.7	.312	10	.246	.600	2.5	10	.010	.058	28
WSM-50 I	.500	1/2	12.7	.312	10	.264	.660	2.5	11	.010	.058	25
WSL-56 A	.562	9/16	14.3	.375	5	.080	.195	2.5	3	.009	.058	43
WSL-56 B	.562	9/16	14.3	.375	5	.125	.260	2.5	4	.009	.058	37
WSL-56 C	.562	9/16	14.3	.375	5	.135	.325	2.5	5	.009	.058	26
WSL-56 D	.562	9/16	14.3	.375	5	.180	.390	2.5	6	.009	.058	24
WSL-56 E	.562	9/16	14.3	.375	5	.190	.455	2.5	7	.009	.058	19
WSL-56 F	.562	9/16	14.3	.375	5	.230	.520	2.5	8	.009	.058	17
WSL-56 G	.562	9/16	14.3	.375	5	.260	.585	2.5	9	.009	.058	15
WSL-56 H	.562	9/16	14.3	.375	5	.285	.650	2.5	10	.009	.058	14
WSL-56 I	.562	9/16	14.3	.375	5	.315	.715	2.5	11	.009	.058	13
WSM-56 A	.562	9/16	14.3	.375	11	.086	.195	2.5	3	.012	.060	101
WSM-56 B	.562	9/16	14.3	.375	11	.123	.260	2.5	4	.012	.060	80
WSM-56 C	.562	9/16	14.3	.375	11	.145	.325	2.5	5	.012	.060	61
WSM-56 D	.562	9/16	14.3	.375	11	.187	.390	2.5	6	.012	.060	54
WSM-56 E	.562	9/16	14.3	.375	11	.209	.455	2.5	7	.012	.060	45
WSM-56 F	.562	9/16	14.3	.375	11	.253	.520	2.5	8	.012	.060	41
WSM-56 G	.562	9/16	14.3	.375	11	.273	.585	2.5	9	.012	.060	35
WSM-56 H	.562	9/16	14.3	.375	11	.318	.650	2.5	10	.012	.060	33
WSM-56 I	.562	9/16	14.3	.375	11	.343	.715	2.5	11	.012	.060	30

PART NUMBERS SHOWN REFLECT MULTI-TURN WAVE SPRINGS WITH PLAIN ENDS.

THE LETTERS SHOWN AFTER THE PART NUMBERS REPRESENT THE NUMBER OF TURNS. WHEN ORDERING, PARTS SHOULD BE PRESENTED WITH THE PART NUMBER, FOLLOWED BY THE MATERIAL, AND THEN THE NUMBER OF TURNS (i.e. WSL-37ST A, WSM-50ST B, WSR-75ST C, ETC.)

FOR FLAT SHIM TOP WAVE SPRINGS, ADD AN 'F' TO THE END OF THE PART NUMBER (i.e. WSL-37ST AF, WSM-50ST BF, WSR-75ST CF, ETC.)

MATERIAL CODES: ST = CARBON STEEL. SQ = 17-7 PH/C STAINLESS STEEL. SPECIAL ALLOYS AVAILABLE UPON REQUEST.

WSL, WSM, WSR Wave Springs

Multi Turn, Inch

Used for low force applications with large deflections:
More turns equals less force. Utilizes nearly half the space as
helical compression springs while producing the same force.

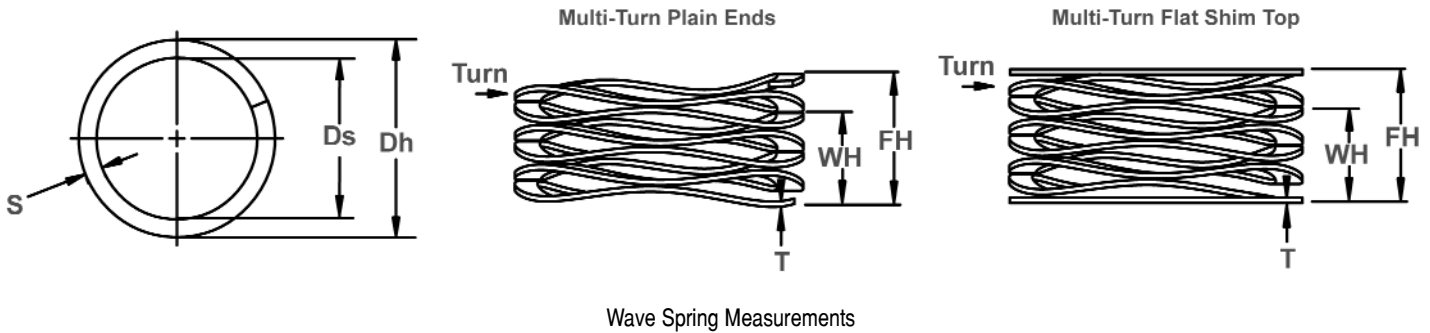

Wave Spring Measurements

WAVE SPRING NO.	HOUSING DIAMETER			SHAFT DIAMETER CLEARANCE	LOAD (lbs.)	WORK HEIGHT	FREE HEIGHT Ref.	NUMBER OF WAVES	NUMBER OF TURNS	THICKNESS	SECTION		SPRING RATE Ref. Lb/in.
	Dh DEC	Dh FRAC	Dh mm								Ds	T	
WSL-62 A	.625	5/8	15.9	.450	6	.055	.180	2.5	3	.010	.058	48	
WSL-62 B	.625	5/8	15.9	.450	6	.068	.240	2.5	4	.010	.058	35	
WSL-62 C	.625	5/8	15.9	.450	6	.085	.300	2.5	5	.010	.058	28	
WSL-62 D	.625	5/8	15.9	.450	6	.106	.360	2.5	6	.010	.058	24	
WSL-62 E	.625	5/8	15.9	.450	6	.128	.420	2.5	7	.010	.058	21	
WSL-62 F	.625	5/8	15.9	.450	6	.165	.540	2.5	9	.010	.058	16	
WSL-62 G	.625	5/8	15.9	.450	6	.202	.660	2.5	11	.010	.058	13	
WSL-62 H	.625	5/8	15.9	.450	6	.238	.780	2.5	13	.010	.058	11	
WSM-62 A	.625	5/8	15.9	.450	12	.104	.180	3.5	3	.010	.058	158	
WSM-62 B	.625	5/8	15.9	.450	12	.130	.240	3.5	4	.010	.058	109	
WSM-62 C	.625	5/8	15.9	.450	12	.175	.300	3.5	5	.010	.058	96	
WSM-62 D	.625	5/8	15.9	.450	12	.206	.360	3.5	6	.010	.058	78	
WSM-62 E	.625	5/8	15.9	.450	12	.246	.420	3.5	7	.010	.058	69	
WSM-62 F	.625	5/8	15.9	.450	12	.317	.540	3.5	9	.010	.058	54	
WSM-62 G	.625	5/8	15.9	.450	12	.386	.660	3.5	11	.010	.058	44	
WSM-62 H	.625	5/8	15.9	.450	12	.454	.780	3.5	13	.010	.058	37	
WSL-75 A	.750	3/4	19.0	.550	7	.142	.250	3.5	3	.008	.071	65	
WSL-75 B	.750	3/4	19.0	.550	7	.187	.333	3.5	4	.008	.071	48	
WSL-75 C	.750	3/4	19.0	.550	7	.246	.417	3.5	5	.008	.071	41	
WSL-75 D	.750	3/4	19.0	.550	7	.285	.500	3.5	6	.008	.071	33	
WSL-75 E	.750	3/4	19.0	.550	7	.348	.583	3.5	7	.008	.071	30	
WSL-75 F	.750	3/4	19.0	.550	7	.446	.750	3.5	9	.008	.071	23	
WSL-75 G	.750	3/4	19.0	.550	7	.580	1.000	3.5	12	.008	.071	17	
WSM-75 A	.750	3/4	19.0	.550	13	.159	.250	3.5	3	.010	.078	143	
WSM-75 B	.750	3/4	19.0	.550	13	.203	.333	3.5	4	.010	.078	100	
WSM-75 C	.750	3/4	19.0	.550	13	.270	.417	3.5	5	.010	.078	88	
WSM-75 D	.750	3/4	19.0	.550	13	.314	.500	3.5	6	.010	.078	70	
WSM-75 E	.750	3/4	19.0	.550	13	.381	.583	3.5	7	.010	.078	64	
WSM-75 F	.750	3/4	19.0	.550	13	.489	.750	3.5	9	.010	.078	50	
WSM-75 G	.750	3/4	19.0	.550	13	.649	1.000	3.5	12	.010	.078	37	
WSR-75 A	.750	3/4	19.0	.550	22	.169	.250	3.5	3	.013	.079	272	
WSR-75 B	.750	3/4	19.0	.550	22	.215	.333	3.5	4	.013	.079	186	
WSR-75 C	.750	3/4	19.0	.550	22	.291	.417	3.5	5	.013	.079	175	
WSR-75 D	.750	3/4	19.0	.550	22	.335	.500	3.5	6	.013	.079	133	
WSR-75 E	.750	3/4	19.0	.550	22	.405	.583	3.5	7	.013	.079	124	
WSR-75 F	.750	3/4	19.0	.550	22	.526	.750	3.5	9	.013	.079	98	
WSR-75 G	.750	3/4	19.0	.550	22	.699	1.000	3.5	12	.013	.079	73	

PART NUMBERS SHOWN REFLECT MULTI-TURN WAVE SPRINGS WITH PLAIN ENDS.

THE LETTERS SHOWN AFTER THE PART NUMBERS REPRESENT THE NUMBER OF TURNS. WHEN ORDERING, PARTS SHOULD BE PRESENTED WITH THE
PART NUMBER, FOLLOWED BY THE MATERIAL, AND THEN THE NUMBER OF TURNS (i.e. WSL-37ST A, WSM-50ST B, WSR-75ST C, ETC.)

FOR FLAT SHIM TOP WAVE SPRINGS, ADD AN 'F' TO THE END OF THE PART NUMBER (i.e. WSL-37ST AF, WSM-50ST BF, WSR-75ST CF, ETC.)

MATERIAL CODES: ST = CARBON STEEL. SQ = 17-7 PH/C STAINLESS STEEL. SPECIAL ALLOYS AVAILABLE UPON REQUEST.

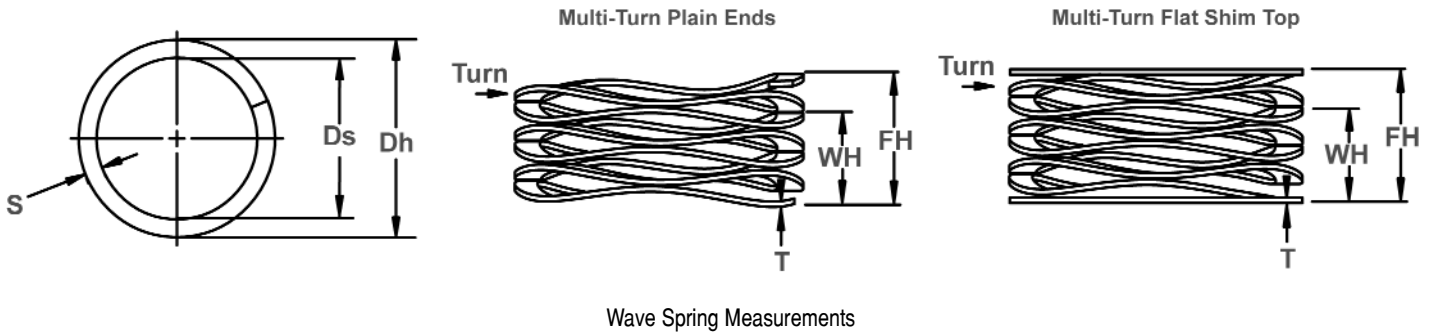

WAVE SPRING NO.	HOUSING DIAMETER			SHAFT DIAMETER CLEARANCE	LOAD (lbs.)	WORK HEIGHT	FREE HEIGHT Ref.	NUMBER OF WAVES	NUMBER OF TURNS	THICKNESS	SECTION	SPRING RATE Ref. Lb/in.
	Dh DEC	Dh FRAC	Dh mm									
WSL-87 A	.875	7/8	22.2	.600	12	.117	.250	3.5	3	.010	.086	90
WSL-87 B	.875	7/8	22.2	.600	12	.158	.333	3.5	4	.010	.086	69
WSL-87 C	.875	7/8	22.2	.600	12	.207	.417	3.5	5	.010	.086	57
WSL-87 D	.875	7/8	22.2	.600	12	.242	.500	3.5	6	.010	.086	47
WSL-87 E	.875	7/8	22.2	.600	12	.287	.583	3.5	7	.010	.086	41
WSL-87 F	.875	7/8	22.2	.600	12	.378	.750	3.5	9	.010	.086	32
WSL-87 G	.875	7/8	22.2	.600	12	.498	1.000	3.5	12	.010	.086	24
WSM-87 A	.875	7/8	22.2	.600	18	.124	.250	3.5	3	.012	.094	148
WSM-87 B	.875	7/8	22.2	.600	18	.164	.333	3.5	4	.012	.094	108
WSM-87 C	.875	7/8	22.2	.600	18	.214	.417	3.5	5	.012	.094	89
WSM-87 D	.875	7/8	22.2	.600	18	.252	.500	3.5	6	.012	.094	76
WSM-87 E	.875	7/8	22.2	.600	18	.296	.583	3.5	7	.012	.094	66
WSM-87 F	.875	7/8	22.2	.600	18	.385	.750	3.5	9	.012	.094	50
WSM-87 G	.875	7/8	22.2	.600	18	.509	1.000	3.5	12	.012	.094	38
WSR-87 A	.875	7/8	22.2	.600	25	.166	.250	3.5	3	.015	.094	298
WSR-87 B	.875	7/8	22.2	.600	25	.214	.333	3.5	4	.015	.094	210
WSR-87 C	.875	7/8	22.2	.600	25	.278	.417	3.5	5	.015	.094	180
WSR-87 D	.875	7/8	22.2	.600	25	.327	.500	3.5	6	.015	.094	145
WSR-87 E	.875	7/8	22.2	.600	25	.395	.583	3.5	7	.015	.094	133
WSR-87 F	.875	7/8	22.2	.600	25	.510	.750	3.5	9	.015	.094	104
WSR-87 G	.875	7/8	22.2	.600	25	.670	1.000	3.5	12	.015	.094	78
WSL-100 A	1.000	1	25.4	.730	12	.084	.250	3.5	3	.010	.086	72
WSL-100 B	1.000	1	25.4	.730	12	.108	.333	3.5	4	.010	.086	53
WSL-100 C	1.000	1	25.4	.730	12	.145	.417	3.5	5	.010	.086	44
WSL-100 D	1.000	1	25.4	.730	12	.165	.500	3.5	6	.010	.086	36
WSL-100 E	1.000	1	25.4	.730	12	.201	.583	3.5	7	.010	.086	31
WSL-100 F	1.000	1	25.4	.730	12	.258	.750	3.5	9	.010	.086	24
WSL-100 G	1.000	1	25.4	.730	12	.342	1.000	3.5	12	.010	.086	18
WSL-100 H	1.000	1	25.4	.730	12	.445	1.250	3.5	15	.010	.086	15
WSL-100 I	1.000	1	25.4	.730	12	.519	1.500	3.5	18	.010	.086	12
WSL-100 J	1.000	1	25.4	.730	12	.633	1.750	3.5	21	.010	.086	11
WSL-100 K	1.000	1	25.4	.730	12	.710	2.000	3.5	24	.010	.086	9

PART NUMBERS SHOWN REFLECT MULTI-TURN WAVE SPRINGS WITH PLAIN ENDS.

THE LETTERS SHOWN AFTER THE PART NUMBERS REPRESENT THE NUMBER OF TURNS. WHEN ORDERING, PARTS SHOULD BE PRESENTED WITH THE PART NUMBER, FOLLOWED BY THE MATERIAL, AND THEN THE NUMBER OF TURNS (i.e. WSL-37ST A, WSM-50ST B, WSR-75ST C, ETC.)

FOR FLAT SHIM TOP WAVE SPRINGS, ADD AN 'F' TO THE END OF THE PART NUMBER (i.e. WSL-37ST AF, WSM-50ST BF, WSR-75ST CF, ETC.)

MATERIAL CODES: ST = CARBON STEEL. SQ = 17-7 PH/C STAINLESS STEEL. SPECIAL ALLOYS AVAILABLE UPON REQUEST.

WSL, WSM, WSR Wave Springs

Multi Turn, Inch

Used for low force applications with large deflections:
More turns equals less force. Utilizes nearly half the space as
helical compression springs while producing the same force.

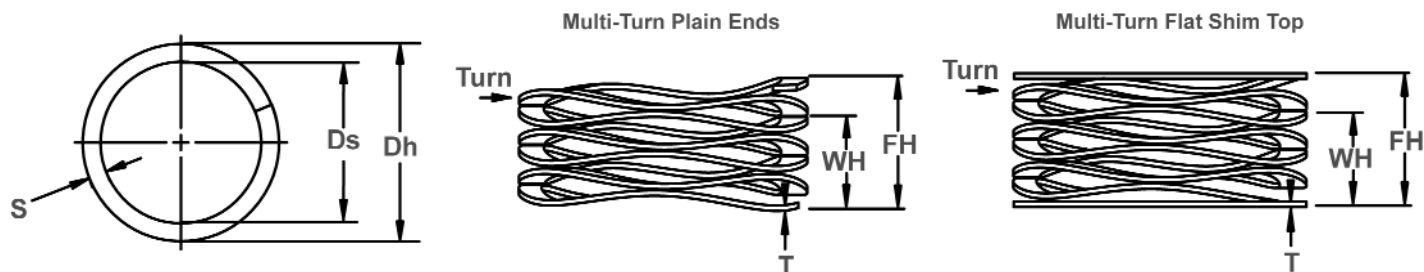

Wave Spring Measurements

WAVE SPRING NO.	HOUSING DIAMETER			SHAFT DIAMETER CLEARANCE Ds	LOAD (lbs.)	WORK HEIGHT WH	FREE HEIGHT Ref. FH	NUMBER OF WAVES	NUMBER OF TURNS	THICKNESS T	SECTION S	SPRING RATE Ref. Lb/in.
	Dh DEC	Dh FRAC	Dh mm									
WSM-100 A	1.000	1	25.4	.730	18	.087	.250	3.5	3	.012	.094	110
WSM-100 B	1.000	1	25.4	.730	18	.113	.333	3.5	4	.012	.094	82
WSM-100 C	1.000	1	25.4	.730	18	.148	.417	3.5	5	.012	.094	67
WSM-100 D	1.000	1	25.4	.730	18	.175	.500	3.5	6	.012	.094	55
WSM-100 E	1.000	1	25.4	.730	18	.212	.583	3.5	7	.012	.094	49
WSM-100 F	1.000	1	25.4	.730	18	.276	.750	3.5	9	.012	.094	38
WSM-100 G	1.000	1	25.4	.730	18	.360	1.000	3.5	12	.012	.094	28
WSM-100 H	1.000	1	25.4	.730	18	.452	1.250	3.5	15	.012	.094	23
WSM-100 I	1.000	1	25.4	.730	18	.549	1.500	3.5	18	.012	.094	19
WSM-100 J	1.000	1	25.4	.730	18	.650	1.750	3.5	21	.012	.094	16
WSM-100 K	1.000	1	25.4	.730	18	.720	2.000	3.5	24	.012	.094	14
WSR-100 A	1.000	1	25.4	.730	25	.131	.250	3.5	3	.015	.094	210
WSR-100 B	1.000	1	25.4	.730	25	.174	.333	3.5	4	.015	.094	157
WSR-100 C	1.000	1	25.4	.730	25	.227	.417	3.5	5	.015	.094	132
WSR-100 D	1.000	1	25.4	.730	25	.266	.500	3.5	6	.015	.094	107
WSR-100 E	1.000	1	25.4	.730	25	.319	.583	3.5	7	.015	.094	95
WSR-100 F	1.000	1	25.4	.730	25	.406	.750	3.5	9	.015	.094	73
WSR-100 G	1.000	1	25.4	.730	25	.541	1.000	3.5	12	.015	.094	54
WSR-100 H	1.000	1	25.4	.730	25	.688	1.250	3.5	15	.015	.094	45
WSR-100 I	1.000	1	25.4	.730	25	.813	1.500	3.5	18	.015	.094	36
WSR-100 J	1.000	1	25.4	.730	25	.957	1.750	3.5	21	.015	.094	32
WSR-100 K	1.000	1	25.4	.730	25	1.083	2.000	3.5	24	.015	.094	27
WSL-112 A	1.125	1-1/8	28.6	.850	12	.146	.300	3.5	3	.012	.094	78
WSL-112 B	1.125	1-1/8	28.6	.850	12	.186	.400	3.5	4	.012	.094	56
WSL-112 C	1.125	1-1/8	28.6	.850	12	.250	.500	3.5	5	.012	.094	48
WSL-112 D	1.125	1-1/8	28.6	.850	12	.295	.600	3.5	6	.012	.094	39
WSL-112 E	1.125	1-1/8	28.6	.850	12	.344	.700	3.5	7	.012	.094	34
WSL-112 F	1.125	1-1/8	28.6	.850	12	.392	.800	3.5	8	.012	.094	29
WSL-112 G	1.125	1-1/8	28.6	.850	12	.488	1.000	3.5	10	.012	.094	23
WSL-112 H	1.125	1-1/8	28.6	.850	12	.659	1.300	3.5	13	.012	.094	19
WSL-112 I	1.125	1-1/8	28.6	.850	12	.807	1.600	3.5	16	.012	.094	15
WSL-112 J	1.125	1-1/8	28.6	.850	12	1.017	2.000	3.5	20	.012	.094	12
WSM-112 A	1.125	1-1/8	28.6	.850	20	.160	.300	3.5	3	.015	.094	143
WSM-112 B	1.125	1-1/8	28.6	.850	20	.202	.400	3.5	4	.015	.094	101
WSM-112 C	1.125	1-1/8	28.6	.850	20	.270	.500	3.5	5	.015	.094	87
WSM-112 D	1.125	1-1/8	28.6	.850	20	.318	.600	3.5	6	.015	.094	71
WSM-112 E	1.125	1-1/8	28.6	.850	20	.381	.700	3.5	7	.015	.094	63
WSM-112 F	1.125	1-1/8	28.6	.850	20	.427	.800	3.5	8	.015	.094	54
WSM-112 G	1.125	1-1/8	28.6	.850	20	.536	1.000	3.5	10	.015	.094	43
WSM-112 H	1.125	1-1/8	28.6	.850	20	.708	1.300	3.5	13	.015	.094	34
WSM-112 I	1.125	1-1/8	28.6	.850	20	.861	1.600	3.5	16	.015	.094	27
WSM-112 J	1.125	1-1/8	28.6	.850	20	1.088	2.000	3.5	20	.015	.094	22

PART NUMBERS SHOWN REFLECT MULTI-TURN WAVE SPRINGS WITH PLAIN ENDS.

THE LETTERS SHOWN AFTER THE PART NUMBERS REPRESENT THE NUMBER OF TURNS. WHEN ORDERING, PARTS SHOULD BE PRESENTED WITH THE PART NUMBER, FOLLOWED BY THE MATERIAL, AND THEN THE NUMBER OF TURNS (i.e. WSL-37ST A, WSM-50ST B, WSR-75ST C, ETC.)

FOR FLAT SHIM TOP WAVE SPRINGS, ADD AN 'F' TO THE END OF THE PART NUMBER (i.e. WSL-37ST AF, WSM-50ST BF, WSR-75ST CF, ETC.)

MATERIAL CODES: ST = CARBON STEEL. SQ = 17-7 PH/C STAINLESS STEEL. SPECIAL ALLOYS AVAILABLE UPON REQUEST.

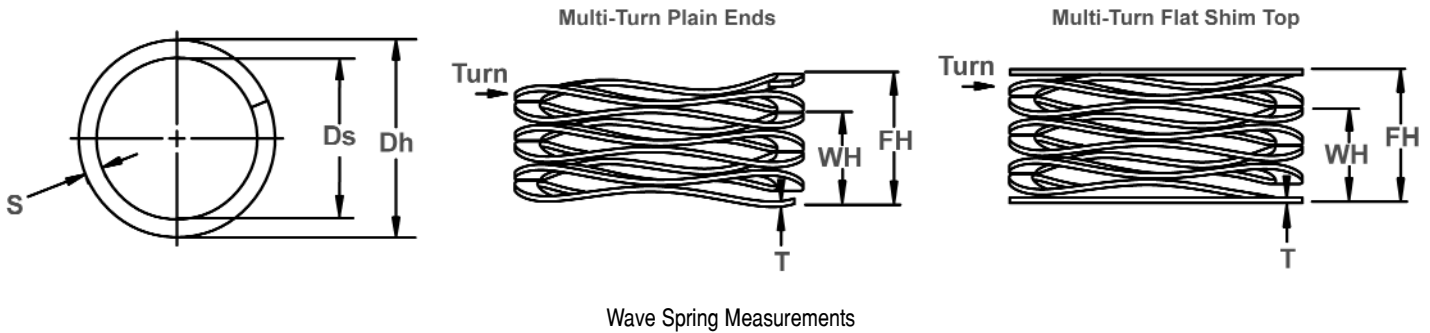

Wave Spring Measurements

WAVE SPRING NO.	HOUSING DIAMETER			SHAFT DIAMETER CLEARANCE	LOAD (lbs.)	WORK HEIGHT	FREE HEIGHT Ref.	NUMBER OF WAVES	NUMBER OF TURNS	THICKNESS	SECTION	SPRING RATE Ref. Lb/in.
	Dh DEC	Dh FRAC	Dh mm									
WSR-112 A	1.125	1-1/8	28.6	.850	30	.178	.300	3.5	3	.018	.094	246
WSR-112 B	1.125	1-1/8	28.6	.850	30	.229	.400	3.5	4	.018	.094	175
WSR-112 C	1.125	1-1/8	28.6	.850	30	.303	.500	3.5	5	.018	.094	152
WSR-112 D	1.125	1-1/8	28.6	.850	30	.350	.600	3.5	6	.018	.094	120
WSR-112 E	1.125	1-1/8	28.6	.850	30	.421	.700	3.5	7	.018	.094	108
WSR-112 F	1.125	1-1/8	28.6	.850	30	.470	.800	3.5	8	.018	.094	91
WSR-112 G	1.125	1-1/8	28.6	.850	30	.593	1.000	3.5	10	.018	.094	74
WSR-112 H	1.125	1-1/8	28.6	.850	30	.787	1.300	3.5	13	.018	.094	58
WSR-112 I	1.125	1-1/8	28.6	.850	30	.956	1.600	3.5	16	.018	.094	47
WSR-112 J	1.125	1-1/8	28.6	.850	30	1.202	2.000	3.5	20	.018	.094	38
WSL-125 A	1.250	1-1/4	31.7	1.000	12	.084	.300	3.5	3	.012	.094	56
WSL-125 B	1.250	1-1/4	31.7	1.000	12	.113	.400	3.5	4	.012	.094	42
WSL-125 C	1.250	1-1/4	31.7	1.000	12	.149	.500	3.5	5	.012	.094	34
WSL-125 D	1.250	1-1/4	31.7	1.000	12	.172	.600	3.5	6	.012	.094	28
WSL-125 E	1.250	1-1/4	31.7	1.000	12	.207	.700	3.5	7	.012	.094	24
WSL-125 F	1.250	1-1/4	31.7	1.000	12	.227	.800	3.5	8	.012	.094	21
WSL-125 G	1.250	1-1/4	31.7	1.000	12	.301	1.000	3.5	10	.012	.094	17
WSL-125 H	1.250	1-1/4	31.7	1.000	12	.395	1.300	3.5	13	.012	.094	13
WSL-125 I	1.250	1-1/4	31.7	1.000	12	.467	1.600	3.5	16	.012	.094	11
WSL-125 J	1.250	1-1/4	31.7	1.000	12	.591	2.000	3.5	20	.012	.094	9
WSM-125 A	1.250	1-1/4	31.7	1.000	20	.124	.300	3.5	3	.015	.094	114
WSM-125 B	1.250	1-1/4	31.7	1.000	20	.165	.400	3.5	4	.015	.094	85
WSM-125 C	1.250	1-1/4	31.7	1.000	20	.215	.500	3.5	5	.015	.094	70
WSM-125 D	1.250	1-1/4	31.7	1.000	20	.253	.600	3.5	6	.015	.094	58
WSM-125 E	1.250	1-1/4	31.7	1.000	20	.303	.700	3.5	7	.015	.094	50
WSM-125 F	1.250	1-1/4	31.7	1.000	20	.341	.800	3.5	8	.015	.094	44
WSM-125 G	1.250	1-1/4	31.7	1.000	20	.427	1.000	3.5	10	.015	.094	35
WSM-125 H	1.250	1-1/4	31.7	1.000	20	.577	1.300	3.5	13	.015	.094	28
WSM-125 I	1.250	1-1/4	31.7	1.000	20	.692	1.600	3.5	16	.015	.094	22
WSM-125 J	1.250	1-1/4	31.7	1.000	20	.866	2.000	3.5	20	.015	.094	18
WSR-125 A	1.250	1-1/4	31.7	1.000	30	.158	.300	3.5	3	.019	.094	210
WSR-125 B	1.250	1-1/4	31.7	1.000	30	.210	.400	3.5	4	.019	.094	158
WSR-125 C	1.250	1-1/4	31.7	1.000	30	.272	.500	3.5	5	.019	.094	132
WSR-125 D	1.250	1-1/4	31.7	1.000	30	.320	.600	3.5	6	.019	.094	107
WSR-125 E	1.250	1-1/4	31.7	1.000	30	.384	.700	3.5	7	.019	.094	95
WSR-125 F	1.250	1-1/4	31.7	1.000	30	.433	.800	3.5	8	.019	.094	82
WSR-125 G	1.250	1-1/4	31.7	1.000	30	.538	1.000	3.5	10	.019	.094	65
WSR-125 H	1.250	1-1/4	31.7	1.000	30	.717	1.300	3.5	13	.019	.094	51
WSR-125 I	1.250	1-1/4	31.7	1.000	30	.878	1.600	3.5	16	.019	.094	42
WSR-125 J	1.250	1-1/4	31.7	1.000	30	1.103	2.000	3.5	20	.019	.094	33

PART NUMBERS SHOWN REFLECT MULTI-TURN WAVE SPRINGS WITH PLAIN ENDS.

THE LETTERS SHOWN AFTER THE PART NUMBERS REPRESENT THE NUMBER OF TURNS. WHEN ORDERING, PARTS SHOULD BE PRESENTED WITH THE PART NUMBER, FOLLOWED BY THE MATERIAL, AND THEN THE NUMBER OF TURNS (i.e. WSL-37ST A, WSM-50ST B, WSR-75ST C, ETC.)

FOR FLAT SHIM TOP WAVE SPRINGS, ADD AN 'F' TO THE END OF THE PART NUMBER (i.e. WSL-37ST AF, WSM-50ST BF, WSR-75ST CF, ETC.)

MATERIAL CODES: ST = CARBON STEEL. SQ = 17-7 PH/C STAINLESS STEEL. SPECIAL ALLOYS AVAILABLE UPON REQUEST.

WSL, WSM, WSR Wave Springs

Multi Turn, Inch

Used for low force applications with large deflections:
More turns equals less force. Utilizes nearly half the space as
helical compression springs while producing the same force.

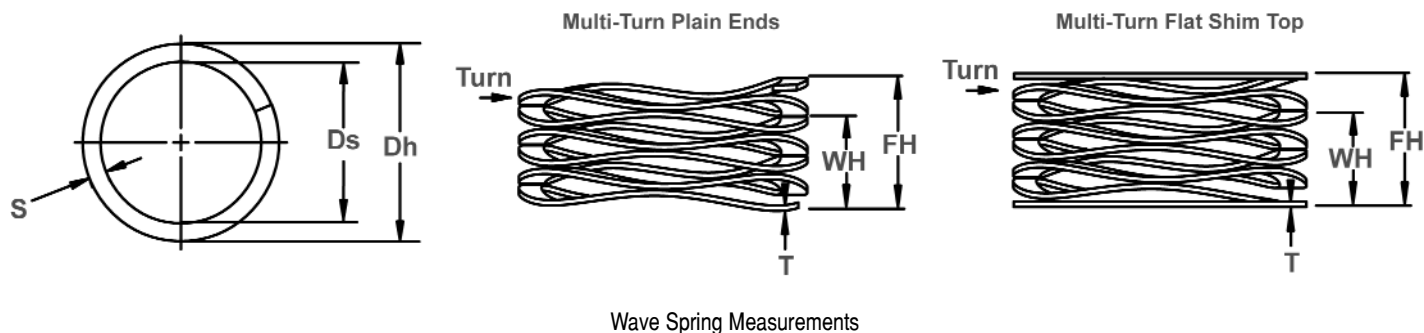

WAVE SPRING NO.	HOUSING DIAMETER			SHAFT DIAMETER CLEARANCE	LOAD (lbs.)	WORK HEIGHT	FREE HEIGHT Ref.	NUMBER OF WAVES	NUMBER OF TURNS	THICKNESS	SECTION	SPRING RATE Ref. Lb/in.
	Dh DEC	Dh FRAC	Dh mm									
WSL-137 A	1.375	1-3/8	34.9	1.030	15	.075	.300	3.5	3	.012	.122	67
WSL-137 B	1.375	1-3/8	34.9	1.030	15	.099	.400	3.5	4	.012	.122	50
WSL-137 C	1.375	1-3/8	34.9	1.030	15	.129	.500	3.5	5	.012	.122	40
WSL-137 D	1.375	1-3/8	34.9	1.030	15	.155	.600	3.5	6	.012	.122	34
WSL-137 E	1.375	1-3/8	34.9	1.030	15	.179	.700	3.5	7	.012	.122	29
WSL-137 F	1.375	1-3/8	34.9	1.030	15	.206	.800	3.5	8	.012	.122	25
WSL-137 G	1.375	1-3/8	34.9	1.030	15	.256	1.000	3.5	10	.012	.122	20
WSL-137 H	1.375	1-3/8	34.9	1.030	15	.341	1.300	3.5	13	.012	.122	16
WSL-137 I	1.375	1-3/8	34.9	1.030	15	.424	1.600	3.5	16	.012	.122	13
WSL-137 J	1.375	1-3/8	34.9	1.030	15	.530	2.000	3.5	20	.012	.122	10
WSM-137 A	1.375	1-3/8	34.9	1.030	25	.142	.300	3.5	3	.016	.133	158
WSM-137 B	1.375	1-3/8	34.9	1.030	25	.186	.400	3.5	4	.016	.133	117
WSM-137 C	1.375	1-3/8	34.9	1.030	25	.240	.500	3.5	5	.016	.133	96
WSM-137 D	1.375	1-3/8	34.9	1.030	25	.281	.600	3.5	6	.016	.133	78
WSM-137 E	1.375	1-3/8	34.9	1.030	25	.340	.700	3.5	7	.016	.133	69
WSM-137 F	1.375	1-3/8	34.9	1.030	25	.384	.800	3.5	8	.016	.133	60
WSM-137 G	1.375	1-3/8	34.9	1.030	25	.486	1.000	3.5	10	.016	.133	49
WSM-137 H	1.375	1-3/8	34.9	1.030	25	.632	1.300	3.5	13	.016	.133	37
WSM-137 I	1.375	1-3/8	34.9	1.030	25	.788	1.600	3.5	16	.016	.133	31
WSM-137 J	1.375	1-3/8	34.9	1.030	25	.982	2.000	3.5	20	.016	.133	25
WSR-137 A	1.375	1-3/8	34.9	1.030	35	.149	.300	3.5	3	.018	.133	232
WSR-137 B	1.375	1-3/8	34.9	1.030	35	.189	.400	3.5	4	.018	.133	166
WSR-137 C	1.375	1-3/8	34.9	1.030	35	.247	.500	3.5	5	.018	.133	138
WSR-137 D	1.375	1-3/8	34.9	1.030	35	.287	.600	3.5	6	.018	.133	112
WSR-137 E	1.375	1-3/8	34.9	1.030	35	.343	.700	3.5	7	.018	.133	98
WSR-137 F	1.375	1-3/8	34.9	1.030	35	.390	.800	3.5	8	.018	.133	85
WSR-137 G	1.375	1-3/8	34.9	1.030	35	.490	1.000	3.5	10	.018	.133	69
WSR-137 H	1.375	1-3/8	34.9	1.030	35	.646	1.300	3.5	13	.018	.133	54
WSR-137 I	1.375	1-3/8	34.9	1.030	35	.793	1.600	3.5	16	.018	.133	43
WSR-137 J	1.375	1-3/8	34.9	1.030	35	1.000	2.000	3.5	20	.018	.133	35
WSL-150 A	1.500	1-1/2	38.1	1.140	20	.129	.300	3.5	3	.016	.133	117
WSL-150 B	1.500	1-1/2	38.1	1.140	20	.164	.400	3.5	4	.016	.133	85
WSL-150 C	1.500	1-1/2	38.1	1.140	20	.213	.500	3.5	5	.016	.133	70
WSL-150 D	1.500	1-1/2	38.1	1.140	20	.247	.600	3.5	6	.016	.133	57
WSL-150 E	1.500	1-1/2	38.1	1.140	20	.301	.700	3.5	7	.016	.133	50
WSL-150 F	1.500	1-1/2	38.1	1.140	20	.337	.800	3.5	8	.016	.133	43
WSL-150 G	1.500	1-1/2	38.1	1.140	20	.430	1.000	3.5	10	.016	.133	35
WSL-150 H	1.500	1-1/2	38.1	1.140	20	.565	1.300	3.5	13	.016	.133	27
WSL-150 I	1.500	1-1/2	38.1	1.140	20	.694	1.600	3.5	16	.016	.133	22
WSL-150 J	1.500	1-1/2	38.1	1.140	20	.866	2.000	3.5	20	.016	.133	18

PART NUMBERS SHOWN REFLECT MULTI-TURN WAVE SPRINGS WITH PLAIN ENDS.

THE LETTERS SHOWN AFTER THE PART NUMBERS REPRESENT THE NUMBER OF TURNS. WHEN ORDERING, PARTS SHOULD BE PRESENTED WITH THE PART NUMBER, FOLLOWED BY THE MATERIAL, AND THEN THE NUMBER OF TURNS (i.e. WSL-37ST A, WSM-50ST B, WSR-75ST C, ETC.)

FOR FLAT SHIM TOP WAVE SPRINGS, ADD AN 'F' TO THE END OF THE PART NUMBER (i.e. WSL-37ST AF, WSM-50ST BF, WSR-75ST CF, ETC.)

MATERIAL CODES: ST = CARBON STEEL. SQ = 17-7 PH/C STAINLESS STEEL. SPECIAL ALLOYS AVAILABLE UPON REQUEST.

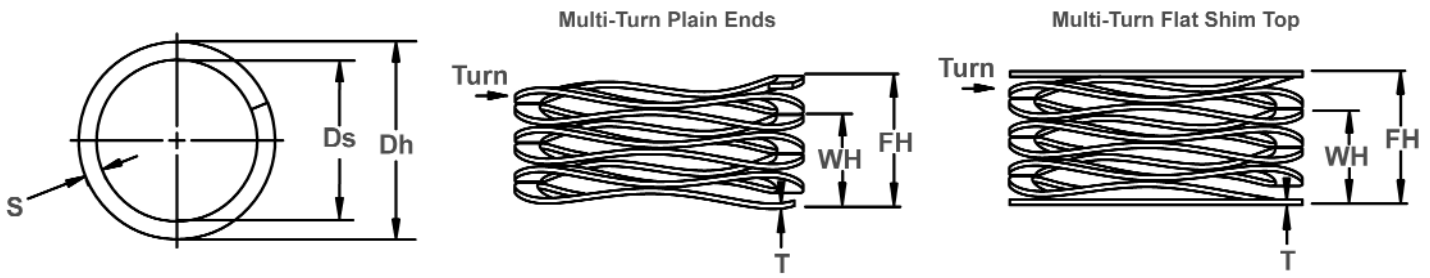

Wave Spring Measurements

WAVE SPRING NO.	HOUSING DIAMETER			SHAFT DIAMETER CLEARANCE Ds	LOAD (lbs.)	WORK HEIGHT WH	FREE HEIGHT Ref. FH	NUMBER OF WAVES	NUMBER OF TURNS	THICKNESS T	SECTION S	SPRING RATE Ref. Lb/in.
	Dh DEC	Dh FRAC	Dh mm									
WSM-150 A	1.500	1-1/2	38.1	1.140	35	.122	.300	3.5	3	.018	.133	197
WSM-150 B	1.500	1-1/2	38.1	1.140	35	.158	.400	3.5	4	.018	.133	145
WSM-150 C	1.500	1-1/2	38.1	1.140	35	.206	.500	3.5	5	.018	.133	119
WSM-150 D	1.500	1-1/2	38.1	1.140	35	.241	.600	3.5	6	.018	.133	97
WSM-150 E	1.500	1-1/2	38.1	1.140	35	.291	.700	3.5	7	.018	.133	86
WSM-150 F	1.500	1-1/2	38.1	1.140	35	.324	.800	3.5	8	.018	.133	74
WSM-150 G	1.500	1-1/2	38.1	1.140	35	.409	1.000	3.5	10	.018	.133	59
WSM-150 H	1.500	1-1/2	38.1	1.140	35	.540	1.300	3.5	13	.018	.133	46
WSM-150 I	1.500	1-1/2	38.1	1.140	35	.657	1.600	3.5	16	.018	.133	37
WSM-150 J	1.500	1-1/2	38.1	1.140	35	.835	2.000	3.5	20	.018	.133	30
WSR-150 A	1.500	1-1/2	38.1	1.140	60	.166	.300	4.5	3	.018	.133	448
WSR-150 B	1.500	1-1/2	38.1	1.140	60	.216	.400	4.5	4	.018	.133	326
WSR-150 C	1.500	1-1/2	38.1	1.140	60	.278	.500	4.5	5	.018	.133	270
WSR-150 D	1.500	1-1/2	38.1	1.140	60	.329	.600	4.5	6	.018	.133	221
WSR-150 E	1.500	1-1/2	38.1	1.140	60	.390	.700	4.5	7	.018	.133	194
WSR-150 F	1.500	1-1/2	38.1	1.140	60	.443	.800	4.5	8	.018	.133	168
WSR-150 G	1.500	1-1/2	38.1	1.140	60	.555	1.000	4.5	10	.018	.133	135
WSR-150 H	1.500	1-1/2	38.1	1.140	60	.726	1.300	4.5	13	.018	.133	105
WSR-150 I	1.500	1-1/2	38.1	1.140	60	.890	1.600	4.5	16	.018	.133	85
WSR-150 J	1.500	1-1/2	38.1	1.140	60	1.119	2.000	4.5	20	.018	.133	68
WSL-175 A	1.750	1-3/4	44.4	1.340	25	.155	.375	3.5	3	.018	.143	114
WSL-175 B	1.750	1-3/4	44.4	1.340	25	.200	.500	3.5	4	.018	.143	83
WSL-175 C	1.750	1-3/4	44.4	1.340	25	.265	.625	3.5	5	.018	.143	69
WSL-175 D	1.750	1-3/4	44.4	1.340	25	.310	.750	3.5	6	.018	.143	57
WSL-175 E	1.750	1-3/4	44.4	1.340	25	.367	.870	3.5	7	.018	.143	50
WSL-175 F	1.750	1-3/4	44.4	1.340	25	.415	1.000	3.5	8	.018	.143	43
WSL-175 G	1.750	1-3/4	44.4	1.340	25	.523	1.250	3.5	10	.018	.143	34
WSL-175 H	1.750	1-3/4	44.4	1.340	25	.638	1.500	3.5	12	.018	.143	29
WSL-175 I	1.750	1-3/4	44.4	1.340	25	.737	1.750	3.5	14	.018	.143	25
WSL-175 J	1.750	1-3/4	44.4	1.340	25	.844	2.000	3.5	16	.018	.143	22
WSM-175 A	1.750	1-3/4	44.4	1.340	50	.188	.375	4.5	3	.018	.143	267
WSM-175 B	1.750	1-3/4	44.4	1.340	50	.244	.500	4.5	4	.018	.143	195
WSM-175 C	1.750	1-3/4	44.4	1.340	50	.315	.625	4.5	5	.018	.143	161
WSM-175 D	1.750	1-3/4	44.4	1.340	50	.374	.750	4.5	6	.018	.143	133
WSM-175 E	1.750	1-3/4	44.4	1.340	50	.452	.870	4.5	7	.018	.143	120
WSM-175 F	1.750	1-3/4	44.4	1.340	50	.505	1.000	4.5	8	.018	.143	101
WSM-175 G	1.750	1-3/4	44.4	1.340	50	.629	1.250	4.5	10	.018	.143	81
WSM-175 H	1.750	1-3/4	44.4	1.340	50	.768	1.500	4.5	12	.018	.143	68
WSM-175 I	1.750	1-3/4	44.4	1.340	50	.899	1.750	4.5	14	.018	.143	59
WSM-175 J	1.750	1-3/4	44.4	1.340	50	1.026	2.000	4.5	16	.018	.143	51

PART NUMBERS SHOWN REFLECT MULTI-TURN WAVE SPRINGS WITH PLAIN ENDS.

THE LETTERS SHOWN AFTER THE PART NUMBERS REPRESENT THE NUMBER OF TURNS. WHEN ORDERING, PARTS SHOULD BE PRESENTED WITH THE PART NUMBER, FOLLOWED BY THE MATERIAL, AND THEN THE NUMBER OF TURNS (i.e. WSL-37ST A, WSM-50ST B, WSR-75ST C, ETC.)

FOR FLAT SHIM TOP WAVE SPRINGS, ADD AN 'F' TO THE END OF THE PART NUMBER (i.e. WSL-37ST AF, WSM-50ST BF, WSR-75ST CF, ETC.)

MATERIAL CODES: ST = CARBON STEEL. SQ = 17-7 PH/C STAINLESS STEEL. SPECIAL ALLOYS AVAILABLE UPON REQUEST.

WSL, WSM, WSR Wave Springs

Multi Turn, Inch

Used for low force applications with large deflections:
More turns equals less force. Utilizes nearly half the space as
helical compression springs while producing the same force.

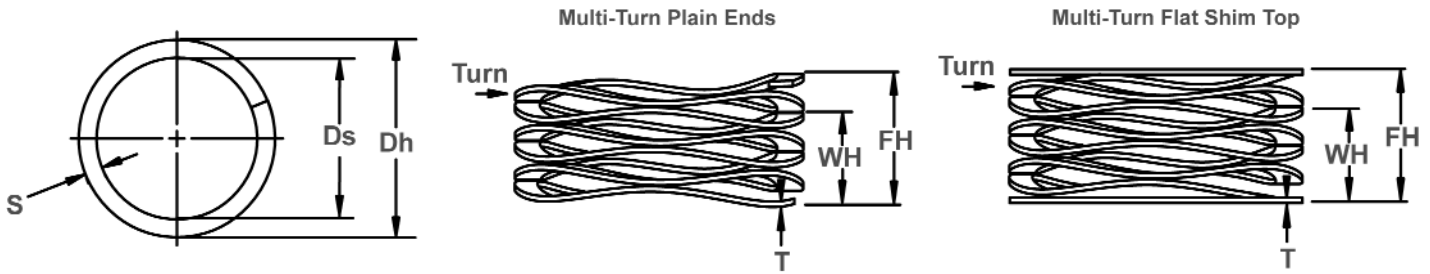

Wave Spring Measurements

WAVE SPRING NO.	HOUSING DIAMETER			SHAFT DIAMETER CLEARANCE Ds	LOAD (lbs.)	WORK HEIGHT WH	FREE HEIGHT Ref. FH	NUMBER OF WAVES	NUMBER OF TURNS	THICKNESS T	SECTION S	SPRING RATE Ref. Lb/in.
	Dh DEC	Dh FRAC	Dh mm									
WSR-175 A	1.750	1-3/4	44.4	1.340	90	.232	.375	4.5	3	.024	.148	629
WSR-175 B	1.750	1-3/4	44.4	1.340	90	.314	.500	4.5	4	.024	.148	484
WSR-175 C	1.750	1-3/4	44.4	1.340	90	.409	.625	4.5	5	.024	.148	417
WSR-175 D	1.750	1-3/4	44.4	1.340	90	.482	.750	4.5	6	.024	.148	336
WSR-175 E	1.750	1-3/4	44.4	1.340	90	.577	.870	4.5	7	.024	.148	307
WSR-175 F	1.750	1-3/4	44.4	1.340	90	.651	1.000	4.5	8	.024	.148	258
WSR-175 G	1.750	1-3/4	44.4	1.340	90	.813	1.250	4.5	10	.024	.148	206
WSR-175 H	1.750	1-3/4	44.4	1.340	90	.980	1.500	4.5	12	.024	.148	173
WSR-175 I	1.750	1-3/4	44.4	1.340	90	1.147	1.750	4.5	14	.024	.148	149
WSR-175 J	1.750	1-3/4	44.4	1.340	90	1.317	2.000	4.5	16	.024	.148	132
WSL-200 A	2.000	2	50.8	1.600	25	.094	.375	3.5	3	.018	.143	89
WSL-200 B	2.000	2	50.8	1.600	25	.120	.500	3.5	4	.018	.143	66
WSL-200 C	2.000	2	50.8	1.600	25	.158	.625	3.5	5	.018	.143	54
WSL-200 D	2.000	2	50.8	1.600	25	.179	.750	3.5	6	.018	.143	44
WSL-200 E	2.000	2	50.8	1.600	25	.217	.870	3.5	7	.018	.143	38
WSL-200 F	2.000	2	50.8	1.600	25	.243	1.000	3.5	8	.018	.143	33
WSL-200 G	2.000	2	50.8	1.600	25	.306	1.250	3.5	10	.018	.143	26
WSL-200 H	2.000	2	50.8	1.600	25	.365	1.500	3.5	12	.018	.143	22
WSL-200 I	2.000	2	50.8	1.600	25	.433	1.750	3.5	14	.018	.143	19
WSL-200 J	2.000	2	50.8	1.600	25	.490	2.000	3.5	16	.018	.143	17
WSM-200 A	2.000	2	50.8	1.600	50	.140	.375	4.5	3	.018	.143	213
WSM-200 B	2.000	2	50.8	1.600	50	.184	.500	4.5	4	.018	.143	158
WSM-200 C	2.000	2	50.8	1.600	50	.245	.625	4.5	5	.018	.143	132
WSM-200 D	2.000	2	50.8	1.600	50	.278	.750	4.5	6	.018	.143	106
WSM-200 E	2.000	2	50.8	1.600	50	.345	.870	4.5	7	.018	.143	95
WSM-200 F	2.000	2	50.8	1.600	50	.395	1.000	4.5	8	.018	.143	83
WSM-200 G	2.000	2	50.8	1.600	50	.498	1.250	4.5	10	.018	.143	66
WSM-200 H	2.000	2	50.8	1.600	50	.593	1.500	4.5	12	.018	.143	55
WSM-200 I	2.000	2	50.8	1.600	50	.694	1.750	4.5	14	.018	.143	47
WSM-200 J	2.000	2	50.8	1.600	50	.800	2.000	4.5	16	.018	.143	42
WSR-200 A	2.000	2	50.8	1.600	90	.197	.375	4.5	3	.024	.148	506
WSR-200 B	2.000	2	50.8	1.600	90	.258	.500	4.5	4	.024	.148	372
WSR-200 C	2.000	2	50.8	1.600	90	.332	.625	4.5	5	.024	.148	307
WSR-200 D	2.000	2	50.8	1.600	90	.389	.750	4.5	6	.024	.148	249
WSR-200 E	2.000	2	50.8	1.600	90	.465	.870	4.5	7	.024	.148	222
WSR-200 F	2.000	2	50.8	1.600	90	.525	1.000	4.5	8	.024	.148	189
WSR-200 G	2.000	2	50.8	1.600	90	.661	1.250	4.5	10	.024	.148	153
WSR-200 H	2.000	2	50.8	1.600	90	.781	1.500	4.5	12	.024	.148	125
WSR-200 I	2.000	2	50.8	1.600	90	.941	1.750	4.5	14	.024	.148	111
WSR-200 J	2.000	2	50.8	1.600	90	1.069	2.000	4.5	16	.024	.148	97

PART NUMBERS SHOWN REFLECT MULTI-TURN WAVE SPRINGS WITH PLAIN ENDS.
THE LETTERS SHOWN AFTER THE PART NUMBERS REPRESENT THE NUMBER OF TURNS. WHEN ORDERING, PARTS SHOULD BE PRESENTED WITH THE PART NUMBER, FOLLOWED BY THE MATERIAL, AND THEN THE NUMBER OF TURNS (i.e. WSL-37ST A, WSM-50ST B, WSR-75ST C, ETC.)
FOR FLAT SHIM TOP WAVE SPRINGS, ADD AN 'F' TO THE END OF THE PART NUMBER (i.e. WSL-37ST AF, WSM-50ST BF, WSR-75ST CF, ETC.)

MATERIAL CODES: ST = CARBON STEEL. SQ = 17-7 PH/C STAINLESS STEEL. SPECIAL ALLOYS AVAILABLE UPON REQUEST.

Multi Turn, Metric

Used for low force applications with large deflections:

More turns equals less force. Utilizes nearly half the space as helical compression springs while producing the same force.

MWL, MWM, MWR Wave Springs

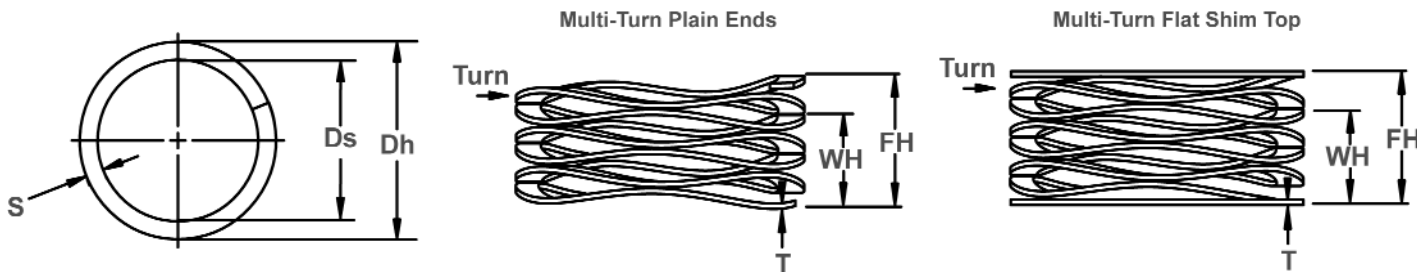
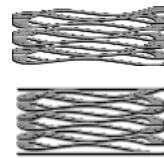

Wave Spring Measurements

WAVE SPRING NO.	HOUSING DIAMETER	SHAFT DIAMETER CLEARANCE	LOAD (N)	WORK HEIGHT	FREE HEIGHT Ref.	NUMBER OF WAVES	NUMBER OF TURNS	THICKNESS	SECTION	SPRING RATE Ref. N/mm
	Dh mm	Ds		WH	FH			T	S	
MWL-6 A*	6	4	6	0.61	1.52	2.5	3	0.13	0.51	6.56
MWL-6 B*	6	4	6	0.81	2.03	2.5	4	0.13	0.51	4.92
MWL-6 C*	6	4	6	1.02	2.54	2.5	5	0.13	0.51	3.94
MWL-6 D*	6	4	6	1.22	3.05	2.5	6	0.13	0.51	3.28
MWL-6 E*	6	4	6	1.42	3.56	2.5	7	0.13	0.51	2.81
MWL-6 F*	6	4	6	1.63	4.06	2.5	8	0.13	0.51	2.46
MWL-6 G*	6	4	6	1.83	4.57	2.5	9	0.13	0.51	2.19
MWL-6 H*	6	4	6	2.24	5.59	2.5	11	0.13	0.51	1.79
MWL-6 I*	6	4	6	2.64	6.60	2.5	13	0.13	0.51	1.51
MWM-6 A*	6	4	12	0.74	1.52	2.5	3	0.15	0.61	15.24
MWM-6 B*	6	4	12	0.97	2.03	2.5	4	0.15	0.61	11.25
MWM-6 C*	6	4	12	1.22	2.54	2.5	5	0.15	0.61	9.09
MWM-6 D*	6	4	12	1.47	3.05	2.5	6	0.15	0.61	7.62
MWM-6 E*	6	4	12	1.70	3.56	2.5	7	0.15	0.61	6.47
MWM-6 F*	6	4	12	1.96	4.06	2.5	8	0.15	0.61	5.69
MWM-6 G*	6	4	12	2.18	4.57	2.5	9	0.15	0.61	5.03
MWM-6 H*	6	4	12	2.69	5.59	2.5	11	0.15	0.61	4.14
MWM-6 I*	6	4	12	3.18	6.60	2.5	13	0.15	0.61	3.50
MWL-8 A	8	5	15	1.70	2.82	2.5	3	0.20	0.81	13.42
MWL-8 B	8	5	15	2.39	3.76	2.5	4	0.20	0.81	10.94
MWL-8 C	8	5	15	2.74	4.70	2.5	5	0.20	0.81	7.67
MWL-8 D	8	5	15	3.56	5.64	2.5	6	0.20	0.81	7.20
MWL-8 E	8	5	15	4.01	6.58	2.5	7	0.20	0.81	5.85
MWL-8 F	8	5	15	4.57	7.52	2.5	8	0.20	0.81	5.09
MWL-8 G	8	5	15	5.26	8.46	2.5	9	0.20	0.81	4.69
MWL-8 H	8	5	15	6.35	10.34	2.5	11	0.20	0.81	3.76
MWL-8 I	8	5	15	7.37	12.22	2.5	13	0.20	0.81	3.09
MWM-8 A	8	5	30	1.78	2.82	2.5	3	0.25	0.81	28.81
MWM-8 B	8	5	30	2.54	3.76	2.5	4	0.25	0.81	24.61
MWM-8 C	8	5	30	3.05	4.70	2.5	5	0.25	0.81	18.17
MWM-8 D	8	5	30	3.81	5.64	2.5	6	0.25	0.81	16.40
MWM-8 E	8	5	30	4.32	6.58	2.5	7	0.25	0.81	13.27
MWM-8 F	8	5	30	4.95	7.52	2.5	8	0.25	0.81	11.69
MWM-8 G	8	5	30	5.59	8.46	2.5	9	0.25	0.81	10.45
MWM-8 H	8	5	30	6.86	10.34	2.5	11	0.25	0.81	8.62
MWM-8 I	8	5	30	7.87	12.22	2.5	13	0.25	0.81	6.91

*Not available with shim ends

ALL DIMENSIONS IN MILLIMETERS UNLESS OTHERWISE SPECIFIED.

PART NUMBERS SHOWN REFLECT MULTI-TURN WAVE SPRINGS WITH PLAIN ENDS.

THE LETTERS SHOWN AFTER THE PART NUMBERS REPRESENT THE NUMBER OF TURNS. WHEN ORDERING, PARTS SHOULD BE PRESENTED WITH THE PART NUMBER, FOLLOWED BY THE MATERIAL, AND THEN THE NUMBER OF TURNS (i.e. MWL-8ST A, MWM-10ST B, MWR-14ST C, ETC.)

FOR FLAT SHIM TOP WAVE SPRINGS, ADD AN 'F' TO THE END OF THE PART NUMBER (i.e. MWL-8ST AF, MWM-10ST BF, MWR-14ST CF, ETC.)

MATERIAL CODES: ST = CARBON STEEL. SQ = 17-7 PH/C STAINLESS STEEL. SPECIAL ALLOYS AVAILABLE UPON REQUEST.



MWL, MWM, MWR Wave Springs

Multi Turn, Metric

Used for low force applications with large deflections:
More turns equals less force. Utilizes nearly half the space as
helical compression springs while producing the same force.

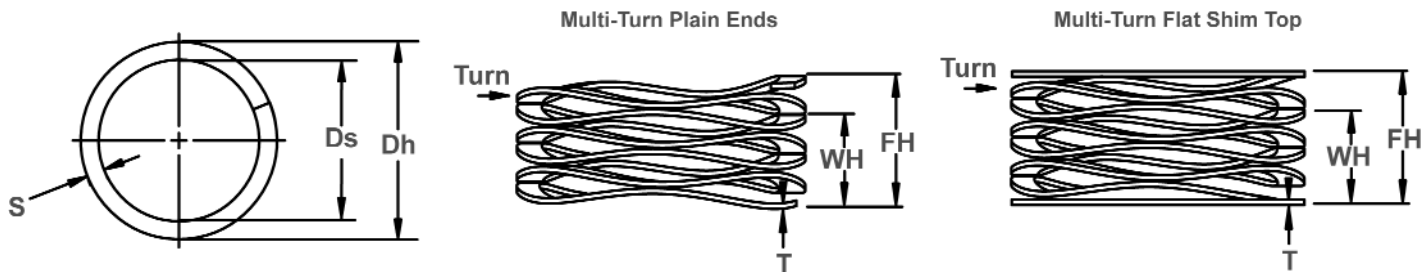

Wave Spring Measurements

WAVE SPRING NO.	HOUSING DIAMETER		SHAFT DIAMETER CLEARANCE	LOAD (N)	WORK HEIGHT	FREE HEIGHT Ref.	NUMBER OF WAVES	NUMBER OF TURNS	THICKNESS	SECTION	SPRING RATE Ref. N/mm
	Dh mm	Ds									
MWL-10 A	10	7	18	1.91	3.96	2.5	3	0.20	0.81	8.75	
MWL-10 B	10	7	18	2.54	5.28	2.5	4	0.20	0.81	6.56	
MWL-10 C	10	7	18	3.15	6.60	2.5	5	0.20	0.81	5.21	
MWL-10 D	10	7	18	3.78	7.92	2.5	6	0.20	0.81	4.35	
MWL-10 E	10	7	18	4.42	9.25	2.5	7	0.20	0.81	3.73	
MWL-10 F	10	7	18	5.05	10.57	2.5	8	0.20	0.81	3.27	
MWL-10 G	10	7	18	5.69	11.89	2.5	9	0.20	0.81	2.90	
MWL-10 H	10	7	18	6.32	13.21	2.5	10	0.20	0.81	2.61	
MWL-10 I	10	7	18	6.96	14.53	2.5	11	0.20	0.81	2.38	
MWM-10 A	10	7	35	2.03	3.96	2.5	3	0.28	0.81	18.13	
MWM-10 B	10	7	35	2.79	5.28	2.5	4	0.28	0.81	14.06	
MWM-10 C	10	7	35	3.56	6.60	2.5	5	0.28	0.81	11.48	
MWM-10 D	10	7	35	4.32	7.92	2.5	6	0.28	0.81	9.70	
MWM-10 E	10	7	35	5.08	9.25	2.5	7	0.28	0.81	8.40	
MWM-10 F	10	7	35	5.84	10.57	2.5	8	0.28	0.81	7.41	
MWM-10 G	10	7	35	6.60	11.89	2.5	9	0.28	0.81	6.62	
MWM-10 H	10	7	35	7.37	13.21	2.5	10	0.28	0.81	5.99	
MWM-10 I	10	7	35	8.13	14.53	2.5	11	0.28	0.81	5.47	
MWL-12 A	12	9	20	1.47	4.34	2.5	3	0.20	1.02	6.97	
MWL-12 B	12	9	20	1.98	5.79	2.5	4	0.20	1.02	5.25	
MWL-12 C	12	9	20	2.46	7.24	2.5	5	0.20	1.02	4.19	
MWL-12 D	12	9	20	2.95	8.69	2.5	6	0.20	1.02	3.48	
MWL-12 E	12	9	20	3.45	10.13	2.5	7	0.20	1.02	2.99	
MWL-12 F	12	9	20	3.94	11.58	2.5	8	0.20	1.02	2.62	
MWL-12 G	12	9	20	4.45	13.03	2.5	9	0.20	1.02	2.33	
MWL-12 H	12	9	20	4.93	14.48	2.5	10	0.20	1.02	2.09	
MWL-12 I	12	9	20	5.44	15.93	2.5	11	0.20	1.02	1.91	
MWM-12 A	12	8.5	40	2.36	4.34	2.5	3	0.28	1.17	20.19	
MWM-12 B	12	8.5	40	3.18	5.79	2.5	4	0.28	1.17	15.29	
MWM-12 C	12	8.5	40	3.96	7.24	2.5	5	0.28	1.17	12.21	
MWM-12 D	12	8.5	40	4.75	8.69	2.5	6	0.28	1.17	10.16	
MWM-12 E	12	8.5	40	5.54	10.13	2.5	7	0.28	1.17	8.70	
MWM-12 F	12	8.5	40	6.32	11.58	2.5	8	0.28	1.17	7.61	
MWM-12 G	12	8.5	40	7.11	13.03	2.5	9	0.28	1.17	6.76	
MWM-12 H	12	8.5	40	7.92	14.48	2.5	10	0.28	1.17	6.10	
MWM-12 I	12	8.5	40	8.71	15.93	2.5	11	0.28	1.17	5.55	

ALL DIMENSIONS IN MILLIMETERS UNLESS OTHERWISE SPECIFIED.

PART NUMBERS SHOWN REFLECT MULTI-TURN WAVE SPRINGS WITH PLAIN ENDS.

THE LETTERS SHOWN AFTER THE PART NUMBERS REPRESENT THE NUMBER OF TURNS. WHEN ORDERING, PARTS SHOULD BE PRESENTED WITH THE PART NUMBER, FOLLOWED BY THE MATERIAL, AND THEN THE NUMBER OF TURNS (i.e. MWL-8ST A, MWM-10ST B, MWR-14ST C, ETC.)

FOR FLAT SHIM TOP WAVE SPRINGS, ADD AN 'F' TO THE END OF THE PART NUMBER (i.e. MWL-8ST AF, MWM-10ST BF, MWR-14ST CF, ETC.)

MATERIAL CODES: ST = CARBON STEEL. SQ = 17-7 PH/C STAINLESS STEEL. SPECIAL ALLOYS AVAILABLE UPON REQUEST.

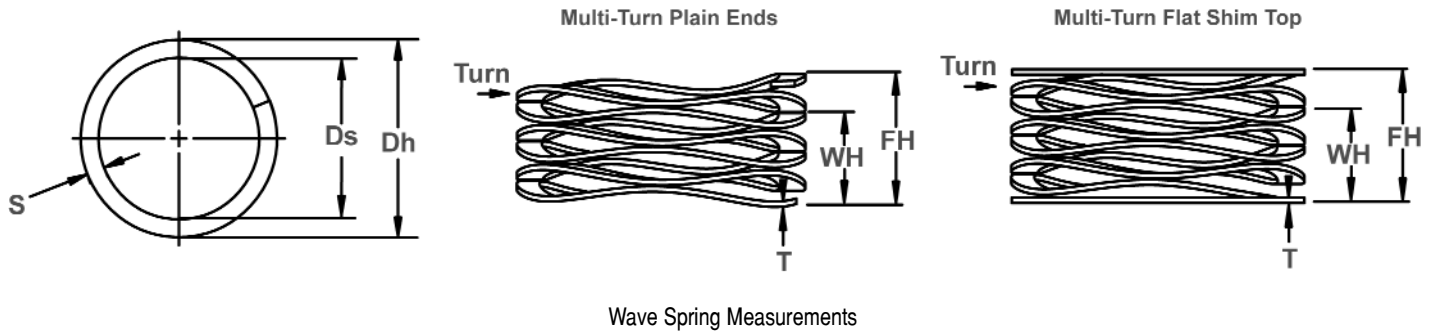

WAVE SPRING NO.	HOUSING DIAMETER		SHAFT DIAMETER CLEARANCE	LOAD (N)	WORK HEIGHT	FREE HEIGHT Ref.	NUMBER OF WAVES	NUMBER OF TURNS	THICKNESS	SECTION	SPRING RATE Ref. N/mm
	Dh mm	Ds									
MWR-12 A	12	8.5	60	1.98	4.34	2.5	3	0.30	1.14	25.40	
MWR-12 B	12	8.5	60	2.64	5.79	2.5	4	0.30	1.14	19.05	
MWR-12 C	12	8.5	60	3.30	7.24	2.5	5	0.30	1.14	15.24	
MWR-12 D	12	8.5	60	3.99	8.69	2.5	6	0.30	1.14	12.77	
MWR-12 E	12	8.5	60	4.65	10.13	2.5	7	0.30	1.14	10.94	
MWR-12 F	12	8.5	60	5.31	11.58	2.5	8	0.30	1.14	9.56	
MWR-12 G	12	8.5	60	5.97	13.03	2.5	9	0.30	1.14	8.50	
MWR-12 H	12	8.5	60	6.63	14.48	2.5	10	0.30	1.14	7.64	
MWR-12 I	12	8.5	60	7.29	15.93	2.5	11	0.30	1.14	6.95	
MWL-14 A	14	10	22	2.18	4.95	2.5	3	0.23	1.47	7.95	
MWL-14 B	14	10	22	2.95	6.60	2.5	4	0.23	1.47	6.01	
MWL-14 C	14	10	22	3.71	8.26	2.5	5	0.23	1.47	4.84	
MWL-14 D	14	10	22	4.52	9.91	2.5	6	0.23	1.47	4.09	
MWL-14 E	14	10	22	5.33	11.56	2.5	7	0.23	1.47	3.54	
MWL-14 F	14	10	22	6.17	13.21	2.5	8	0.23	1.47	3.13	
MWL-14 G	14	10	22	7.01	14.86	2.5	9	0.23	1.47	2.80	
MWL-14 H	14	10	22	7.85	16.51	2.5	10	0.23	1.47	2.54	
MWL-14 I	14	10	22	8.71	18.16	2.5	11	0.23	1.47	2.33	
MWM-14 A	14	10	50	2.18	4.95	2.5	3	0.30	1.52	18.06	
MWM-14 B	14	10	50	2.95	6.60	2.5	4	0.30	1.52	13.67	
MWM-14 C	14	10	50	3.71	8.26	2.5	5	0.30	1.52	11.00	
MWM-14 D	14	10	50	4.52	9.91	2.5	6	0.30	1.52	9.29	
MWM-14 E	14	10	50	5.33	11.56	2.5	7	0.30	1.52	8.03	
MWM-14 F	14	10	50	6.17	13.21	2.5	8	0.30	1.52	7.11	
MWM-14 G	14	10	50	7.01	14.86	2.5	9	0.30	1.52	6.37	
MWM-14 H	14	10	50	7.85	16.51	2.5	10	0.30	1.52	5.77	
MWM-14 I	14	10	50	8.71	18.16	2.5	11	0.30	1.52	5.29	
MWR-14 A	14	9	80	3.15	4.95	2.5	3	0.38	1.52	44.36	
MWR-14 B	14	9	80	4.19	6.60	2.5	4	0.38	1.52	33.15	
MWR-14 C	14	9	80	5.26	8.26	2.5	5	0.38	1.52	26.69	
MWR-14 D	14	9	80	6.30	9.91	2.5	6	0.38	1.52	22.18	
MWR-14 E	14	9	80	7.34	11.56	2.5	7	0.38	1.52	18.97	
MWR-14 F	14	9	80	8.41	13.21	2.5	8	0.38	1.52	16.66	
MWR-14 G	14	9	80	9.45	14.86	2.5	9	0.38	1.52	14.79	
MWR-14 H	14	9	80	10.49	16.51	2.5	10	0.38	1.52	13.29	
MWR-14 I	14	9	80	11.56	18.16	2.5	11	0.38	1.52	12.11	

ALL DIMENSIONS IN MILLIMETERS UNLESS OTHERWISE SPECIFIED.
 PART NUMBERS SHOWN REFLECT MULTI-TURN WAVE SPRINGS WITH PLAIN ENDS.
 THE LETTERS SHOWN AFTER THE PART NUMBERS REPRESENT THE NUMBER OF TURNS. WHEN ORDERING, PARTS SHOULD BE PRESENTED WITH THE PART NUMBER, FOLLOWED BY THE MATERIAL, AND THEN THE NUMBER OF TURNS (i.e. MWL-8ST A, MWM-10ST B, MWR-14ST C, ETC.)
 FOR FLAT SHIM TOP WAVE SPRINGS, ADD AN 'F' TO THE END OF THE PART NUMBER (i.e. MWL-8ST AF, MWM-10ST BF, MWR-14ST CF, ETC.)

MATERIAL CODES: ST = CARBON STEEL. SQ = 17-7 PH/C STAINLESS STEEL. SPECIAL ALLOYS AVAILABLE UPON REQUEST.

MWL, MWM, MWR Wave Springs

Multi Turn, Metric

Used for low force applications with large deflections:
More turns equals less force. Utilizes nearly half the space as
helical compression springs while producing the same force.

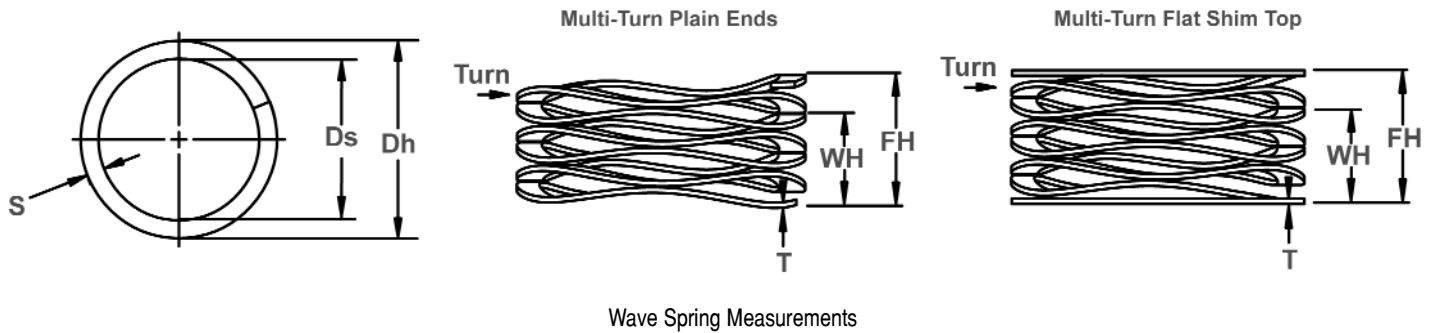

Wave Spring Measurements

WAVE SPRING NO.	HOUSING DIAMETER	SHAFT DIAMETER CLEARANCE	LOAD (N)	WORK HEIGHT	FREE HEIGHT Ref.	NUMBER OF WAVES	NUMBER OF TURNS	THICKNESS	SECTION	SPRING RATE Ref. N/mm
								Dh mm	Ds	
MWL-15 A	15	11	25	2.57	5.18	2.5	3	0.25	1.47	9.56
MWL-15 B	15	11	25	3.43	6.91	2.5	4	0.25	1.47	7.18
MWL-15 C	15	11	25	4.27	8.64	2.5	5	0.25	1.47	5.72
MWL-15 D	15	11	25	5.13	10.36	2.5	6	0.25	1.47	4.78
MWL-15 E	15	11	25	5.99	12.09	2.5	7	0.25	1.47	4.10
MWL-15 F	15	11	25	6.83	13.82	2.5	8	0.25	1.47	3.58
MWL-15 G	15	11	25	7.70	15.54	2.5	9	0.25	1.47	3.19
MWL-15 H	15	11	25	8.53	17.27	2.5	10	0.25	1.47	2.86
MWL-15 I	15	11	25	9.40	19.00	2.5	11	0.25	1.47	2.60
MWM-15 A	15	10	50	3.43	5.18	3.5	3	0.23	1.47	28.53
MWM-15 B	15	10	50	4.57	6.91	3.5	4	0.23	1.47	21.40
MWM-15 C	15	10	50	5.72	8.64	3.5	5	0.23	1.47	17.12
MWM-15 D	15	10	50	6.86	10.36	3.5	6	0.23	1.47	14.26
MWM-15 E	15	10	50	8.00	12.09	3.5	7	0.23	1.47	12.23
MWM-15 F	15	10	50	9.14	13.82	3.5	8	0.23	1.47	10.70
MWM-15 G	15	10	50	10.29	15.54	3.5	9	0.23	1.47	9.51
MWM-15 H	15	10	50	11.43	17.27	3.5	10	0.23	1.47	8.56
MWM-15 I	15	10	50	12.57	19.00	3.5	11	0.23	1.47	7.78
MWR-15 A	15	10	80	3.20	5.18	3.5	3	0.25	1.47	40.38
MWR-15 B	15	10	80	4.19	6.91	3.5	4	0.25	1.47	29.44
MWR-15 C	15	10	80	5.23	8.64	3.5	5	0.25	1.47	23.50
MWR-15 D	15	10	80	6.27	10.36	3.5	6	0.25	1.47	19.56
MWR-15 E	15	10	80	7.32	12.09	3.5	7	0.25	1.47	16.75
MWR-15 F	15	10	80	8.36	13.82	3.5	8	0.25	1.47	14.65
MWR-15 G	15	10	80	9.40	15.54	3.5	9	0.25	1.47	13.01
MWR-15 H	15	10	80	10.46	17.27	3.5	10	0.25	1.47	11.75
MWR-15 I	15	10	80	11.51	19.00	3.5	11	0.25	1.47	10.68
MWL-16 A	16	11	25	2.11	5.41	2.5	3	0.25	1.47	7.57
MWL-16 B	16	11	25	2.79	7.21	2.5	4	0.25	1.47	5.66
MWL-16 C	16	11	25	3.51	9.02	2.5	5	0.25	1.47	4.54
MWL-16 D	16	11	25	4.19	10.82	2.5	6	0.25	1.47	3.77
MWL-16 E	16	11	25	4.90	12.62	2.5	7	0.25	1.47	3.24
MWL-16 F	16	11	25	6.30	16.23	2.5	9	0.25	1.47	2.52
MWL-16 G	16	11	25	7.70	19.84	2.5	11	0.25	1.47	2.06
MWL-16 H	16	11	25	9.09	23.44	2.5	13	0.25	1.47	1.74

ALL DIMENSIONS IN MILLIMETERS UNLESS OTHERWISE SPECIFIED.

PART NUMBERS SHOWN REFLECT MULTI-TURN WAVE SPRINGS WITH PLAIN ENDS.

THE LETTERS SHOWN AFTER THE PART NUMBERS REPRESENT THE NUMBER OF TURNS. WHEN ORDERING, PARTS SHOULD BE PRESENTED WITH THE PART NUMBER, FOLLOWED BY THE MATERIAL, AND THEN THE NUMBER OF TURNS (i.e. MWL-8ST A, MWM-10ST B, MWR-14ST C, ETC.)

FOR FLAT SHIM TOP WAVE SPRINGS, ADD AN 'F' TO THE END OF THE PART NUMBER (i.e. MWL-8ST AF, MWM-10ST BF, MWR-14ST CF, ETC.)

MATERIAL CODES: ST = CARBON STEEL. SQ = 17-7 PH/C STAINLESS STEEL. SPECIAL ALLOYS AVAILABLE UPON REQUEST.

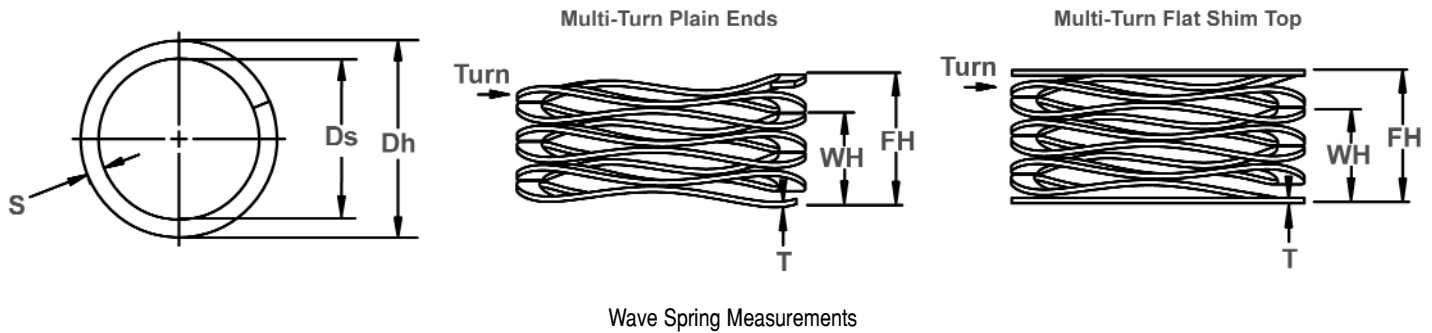

WAVE SPRING NO.	HOUSING DIAMETER		SHAFT DIAMETER CLEARANCE	LOAD (N)	WORK HEIGHT		FREE HEIGHT Ref.	NUMBER OF WAVES	NUMBER OF TURNS	THICKNESS	SECTION	SPRING RATE Ref. N/mm
	Dh mm	Ds			WH	FH						
MWM-16 A	16	11	55	3.63	5.41	3.5	3	0.25	1.47	30.93		
MWM-16 B	16	11	55	4.83	7.21	3.5	4	0.25	1.47	23.04		
MWM-16 C	16	11	55	6.05	9.02	3.5	5	0.25	1.47	18.51		
MWM-16 D	16	11	55	7.24	10.82	3.5	6	0.25	1.47	15.36		
MWM-16 E	16	11	55	8.46	12.62	3.5	7	0.25	1.47	13.20		
MWM-16 F	16	11	55	10.87	16.23	3.5	9	0.25	1.47	10.26		
MWM-16 G	16	11	55	13.28	19.84	3.5	11	0.25	1.47	8.39		
MWM-16 H	16	11	55	15.70	23.44	3.5	13	0.25	1.47	7.10		
MWR-16 A	16	11	90	3.30	5.41	3.5	3	0.30	1.52	42.69		
MWR-16 B	16	11	90	4.57	7.21	3.5	4	0.30	1.52	34.07		
MWR-16 C	16	11	90	5.59	9.02	3.5	5	0.30	1.52	26.25		
MWR-16 D	16	11	90	6.86	10.82	3.5	6	0.30	1.52	22.71		
MWR-16 E	16	11	90	7.87	12.62	3.5	7	0.30	1.52	18.95		
MWR-16 F	16	11	90	10.16	16.23	3.5	9	0.30	1.52	14.83		
MWR-16 G	16	11	90	12.45	19.84	3.5	11	0.30	1.52	12.18		
MWR-16 H	16	11	90	14.73	23.44	3.5	13	0.30	1.52	10.33		
MWL-18 A	18	13	30	3.63	5.72	3.5	3	0.20	1.80	14.40		
MWL-18 B	18	13	30	4.75	7.62	3.5	4	0.20	1.80	10.45		
MWL-18 C	18	13	30	5.94	9.53	3.5	5	0.20	1.80	8.38		
MWL-18 D	18	13	30	7.14	11.43	3.5	6	0.20	1.80	6.99		
MWL-18 E	18	13	30	8.31	13.34	3.5	7	0.20	1.80	5.97		
MWL-18 F	18	13	30	10.69	17.15	3.5	9	0.20	1.80	4.65		
MWL-18 G	18	13	30	14.25	22.86	3.5	12	0.20	1.80	3.48		
MWM-18 A	18	13	55	3.68	5.72	3.5	3	0.25	1.83	27.07		
MWM-18 B	18	13	55	4.98	7.62	3.5	4	0.25	1.83	20.82		
MWM-18 C	18	13	55	6.22	9.53	3.5	5	0.25	1.83	16.66		
MWM-18 D	18	13	55	7.47	11.43	3.5	6	0.25	1.83	13.88		
MWM-18 E	18	13	55	8.74	13.34	3.5	7	0.25	1.83	11.96		
MWM-18 F	18	13	55	11.23	17.15	3.5	9	0.25	1.83	9.29		
MWM-18 G	18	13	55	14.96	22.86	3.5	12	0.25	1.83	6.96		
MWR-18 A	18	13	90	3.84	5.72	3.5	3	0.30	1.83	47.88		
MWR-18 B	18	13	90	5.13	7.62	3.5	4	0.30	1.83	36.16		
MWR-18 C	18	13	90	6.40	9.53	3.5	5	0.30	1.83	28.81		
MWR-18 D	18	13	90	7.70	11.43	3.5	6	0.30	1.83	24.10		
MWR-18 E	18	13	90	8.97	13.34	3.5	7	0.30	1.83	20.60		
MWR-18 F	18	13	90	11.53	17.15	3.5	9	0.30	1.83	16.03		
MWR-18 G	18	13	90	15.37	22.86	3.5	12	0.30	1.83	12.01		

ALL DIMENSIONS IN MILLIMETERS UNLESS OTHERWISE SPECIFIED.

PART NUMBERS SHOWN REFLECT MULTI-TURN WAVE SPRINGS WITH PLAIN ENDS.

THE LETTERS SHOWN AFTER THE PART NUMBERS REPRESENT THE NUMBER OF TURNS. WHEN ORDERING, PARTS SHOULD BE PRESENTED WITH THE PART NUMBER, FOLLOWED BY THE MATERIAL, AND THEN THE NUMBER OF TURNS (i.e. MWL-8ST A, MWM-10ST B, MWR-14ST C, ETC.)

FOR FLAT SHIM TOP WAVE SPRINGS, ADD AN 'F' TO THE END OF THE PART NUMBER (i.e. MWL-8ST AF, MWM-10ST BF, MWR-14ST CF, ETC.)

MATERIAL CODES: ST = CARBON STEEL. SQ = 17-7 PH/C STAINLESS STEEL. SPECIAL ALLOYS AVAILABLE UPON REQUEST.

MWL, MWM, MWR Wave Springs

Multi Turn, Metric

Used for low force applications with large deflections:
More turns equals less force. Utilizes nearly half the space as
helical compression springs while producing the same force.

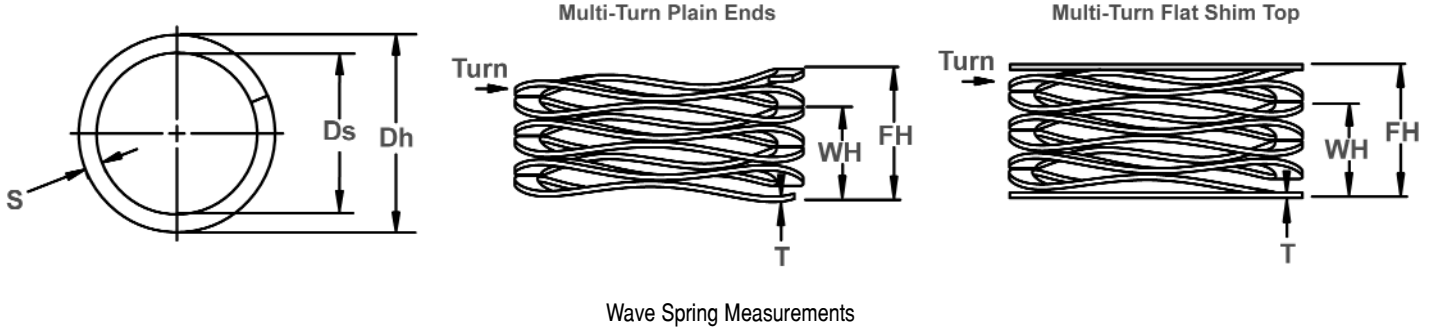

Wave Spring Measurements

WAVE SPRING NO.	HOUSING DIAMETER	SHAFT DIAMETER CLEARANCE	LOAD (N)	WORK HEIGHT	FREE HEIGHT Ref.	NUMBER OF WAVES	NUMBER OF TURNS	THICKNESS	SECTION	SPRING RATE Ref. N/mm
	Dh mm	Ds		WH	FH			T	S	
MWL-20 A	20	15	35	2.72	6.32	3.5	3	0.20	1.80	9.70
MWL-20 B	20	15	35	3.61	8.43	3.5	4	0.20	1.80	7.25
MWL-20 C	20	15	35	4.52	10.54	3.5	5	0.20	1.80	5.81
MWL-20 D	20	15	35	5.41	12.65	3.5	6	0.20	1.80	4.83
MWL-20 E	20	15	35	6.32	14.76	3.5	7	0.20	1.80	4.15
MWL-20 F	20	15	35	8.13	18.97	3.5	9	0.20	1.80	3.23
MWL-20 G	20	15	35	10.82	25.30	3.5	12	0.20	1.80	2.42
MWM-20 A	20	14	70	3.05	6.32	3.5	3	0.25	1.98	21.36
MWM-20 B	20	14	70	4.06	8.43	3.5	4	0.25	1.98	16.02
MWM-20 C	20	14	70	5.08	10.54	3.5	5	0.25	1.98	12.82
MWM-20 D	20	14	70	6.27	12.65	3.5	6	0.25	1.98	10.98
MWM-20 E	20	14	70	7.32	14.76	3.5	7	0.25	1.98	9.41
MWM-20 F	20	14	70	9.17	18.97	3.5	9	0.25	1.98	7.14
MWM-20 G	20	14	70	12.22	25.30	3.5	12	0.25	1.98	5.35
MWR-20 A	20	14	100	4.24	6.32	3.5	3	0.33	2.01	48.01
MWR-20 B	20	14	100	5.66	8.43	3.5	4	0.33	2.01	36.12
MWR-20 C	20	14	100	7.06	10.54	3.5	5	0.33	2.01	28.74
MWR-20 D	20	14	100	8.48	12.65	3.5	6	0.33	2.01	24.01
MWR-20 E	20	14	100	9.91	14.76	3.5	7	0.33	2.01	20.61
MWR-20 F	20	14	100	12.73	18.97	3.5	9	0.33	2.01	16.00
MWR-20 G	20	14	100	16.97	25.30	3.5	12	0.33	2.01	12.00
MWL-25 A	25	19	50	2.06	6.63	3.5	3	0.25	2.18	10.94
MWL-25 B	25	19	50	2.74	8.84	3.5	4	0.25	2.18	8.20
MWL-25 C	25	19	50	3.43	11.05	3.5	5	0.25	2.18	6.56
MWL-25 D	25	19	50	4.11	13.26	3.5	6	0.25	2.18	5.47
MWL-25 E	25	19	50	4.80	15.47	3.5	7	0.25	2.18	4.69
MWL-25 F	25	19	50	6.20	19.89	3.5	9	0.25	2.18	3.65
MWL-25 G	25	19	50	8.26	26.52	3.5	12	0.25	2.18	2.74
MWM-25 A	25	19	80	2.95	6.63	3.5	3	0.30	2.39	21.72
MWM-25 B	25	19	80	3.94	8.84	3.5	4	0.30	2.39	16.32
MWM-25 C	25	19	80	4.90	11.05	3.5	5	0.30	2.39	13.01
MWM-25 D	25	19	80	5.89	13.26	3.5	6	0.30	2.39	10.86
MWM-25 E	25	19	80	6.88	15.47	3.5	7	0.30	2.39	9.32
MWM-25 F	25	19	80	8.84	19.89	3.5	9	0.30	2.39	7.24
MWM-25 G	25	19	80	11.79	26.52	3.5	12	0.30	2.39	5.43

ALL DIMENSIONS IN MILLIMETERS UNLESS OTHERWISE SPECIFIED.

PART NUMBERS SHOWN REFLECT MULTI-TURN WAVE SPRINGS WITH PLAIN ENDS.

THE LETTERS SHOWN AFTER THE PART NUMBERS REPRESENT THE NUMBER OF TURNS. WHEN ORDERING, PARTS SHOULD BE PRESENTED WITH THE PART NUMBER, FOLLOWED BY THE MATERIAL, AND THEN THE NUMBER OF TURNS (i.e. MWL-8ST A, MWM-10ST B, MWR-14ST C, ETC.)

FOR FLAT SHIM TOP WAVE SPRINGS, ADD AN 'F' TO THE END OF THE PART NUMBER (i.e. MWL-8ST AF, MWM-10ST BF, MWR-14ST CF, ETC.)

MATERIAL CODES: ST = CARBON STEEL. SQ = 17-7 PH/C STAINLESS STEEL. SPECIAL ALLOYS AVAILABLE UPON REQUEST.

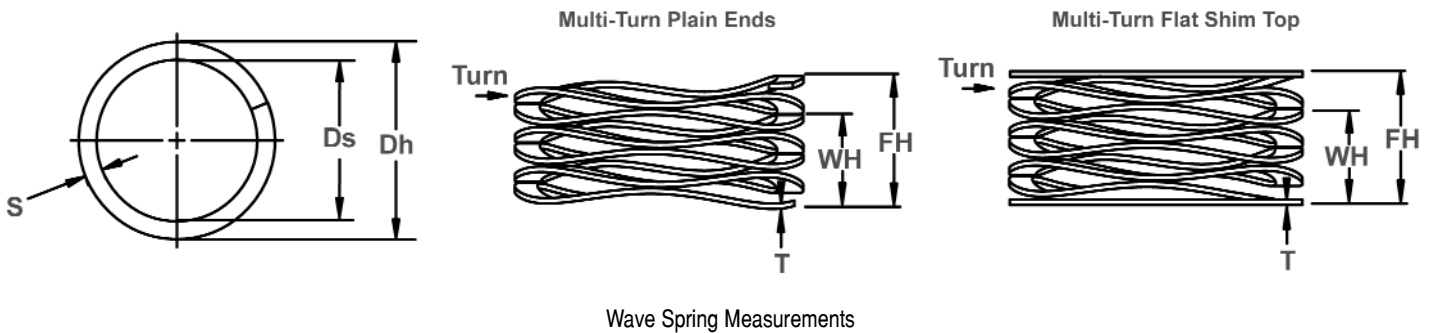

WAVE SPRING NO.	HOUSING DIAMETER	SHAFT DIAMETER CLEARANCE	LOAD (N)	WORK HEIGHT	FREE HEIGHT Ref.	NUMBER OF WAVES	NUMBER OF TURNS	THICKNESS	SECTION	SPRING RATE Ref. N/mm
	Dh mm	Ds		WH	FH			T	S	
MWR-25 A	25	19	110	4.04	6.63	3.5	3	0.38	2.39	42.46
MWR-25 B	25	19	110	5.38	8.84	3.5	4	0.38	2.39	31.84
MWR-25 C	25	19	110	6.73	11.05	3.5	5	0.38	2.39	25.47
MWR-25 D	25	19	110	8.08	13.26	3.5	6	0.38	2.39	21.23
MWR-25 E	25	19	110	9.40	15.47	3.5	7	0.38	2.39	18.12
MWR-25 F	25	19	110	12.12	19.89	3.5	9	0.38	2.39	14.15
MWR-25 G	25	19	110	16.15	26.52	3.5	12	0.38	2.39	10.61
MWL-28 A	28	22	50	3.76	7.24	3.5	3	0.30	2.39	14.37
MWL-28 B	28	22	50	5.00	9.65	3.5	4	0.30	2.39	10.76
MWL-28 C	28	22	50	6.27	12.07	3.5	5	0.30	2.39	8.63
MWL-28 D	28	22	50	7.52	14.48	3.5	6	0.30	2.39	7.18
MWL-28 E	28	22	50	8.79	16.89	3.5	7	0.30	2.39	6.17
MWL-28 F	28	22	50	10.03	19.30	3.5	8	0.30	2.39	5.39
MWL-28 G	28	22	50	11.28	21.72	3.5	9	0.30	2.39	4.79
MWL-28 H	28	22	50	13.79	26.54	3.5	11	0.30	2.39	3.92
MWL-28 I	28	22	50	16.31	31.37	3.5	13	0.30	2.39	3.32
MWM-28 A	28	22	80	4.39	7.24	3.5	3	0.38	2.39	28.12
MWM-28 B	28	22	80	5.84	9.65	3.5	4	0.38	2.39	21.00
MWM-28 C	28	22	80	7.32	12.07	3.5	5	0.38	2.39	16.84
MWM-28 D	28	22	80	8.79	14.48	3.5	6	0.38	2.39	14.06
MWM-28 E	28	22	80	10.24	16.89	3.5	7	0.38	2.39	12.02
MWM-28 F	28	22	80	11.71	19.30	3.5	8	0.38	2.39	10.53
MWM-28 G	28	22	80	13.18	21.72	3.5	9	0.38	2.39	9.37
MWM-28 H	28	22	80	16.10	26.54	3.5	11	0.38	2.39	7.66
MWM-28 I	28	22	80	19.02	31.37	3.5	13	0.38	2.39	6.48
MWR-28 A	28	22	130	4.57	7.24	3.5	3	0.46	2.39	48.74
MWR-28 B	28	22	130	6.07	9.65	3.5	4	0.46	2.39	36.30
MWR-28 C	28	22	130	7.59	12.07	3.5	5	0.46	2.39	29.08
MWR-28 D	28	22	130	9.12	14.48	3.5	6	0.46	2.39	24.26
MWR-28 E	28	22	130	10.64	16.89	3.5	7	0.46	2.39	20.81
MWR-28 F	28	22	130	12.17	19.30	3.5	8	0.46	2.39	18.21
MWR-28 G	28	22	130	13.69	21.72	3.5	9	0.46	2.39	16.20
MWR-28 H	28	22	130	16.71	26.54	3.5	11	0.46	2.39	13.23
MWR-28 I	28	22	130	19.76	31.37	3.5	13	0.46	2.39	11.20

ALL DIMENSIONS IN MILLIMETERS UNLESS OTHERWISE SPECIFIED.

PART NUMBERS SHOWN REFLECT MULTI-TURN WAVE SPRINGS WITH PLAIN ENDS.

THE LETTERS SHOWN AFTER THE PART NUMBERS REPRESENT THE NUMBER OF TURNS. WHEN ORDERING, PARTS SHOULD BE PRESENTED WITH THE PART NUMBER, FOLLOWED BY THE MATERIAL, AND THEN THE NUMBER OF TURNS (i.e. MWL-8ST A, MWM-10ST B, MWR-14ST C, ETC.)

FOR FLAT SHIM TOP WAVE SPRINGS, ADD AN 'F' TO THE END OF THE PART NUMBER (i.e. MWL-8ST AF, MWM-10ST BF, MWR-14ST CF, ETC.)

MATERIAL CODES: ST = CARBON STEEL. SQ = 17-7 PH/C STAINLESS STEEL. SPECIAL ALLOYS AVAILABLE UPON REQUEST.

MWL, MWM, MWR Wave Springs

Multi Turn, Metric

Used for low force applications with large deflections:
More turns equals less force. Utilizes nearly half the space as
helical compression springs while producing the same force.

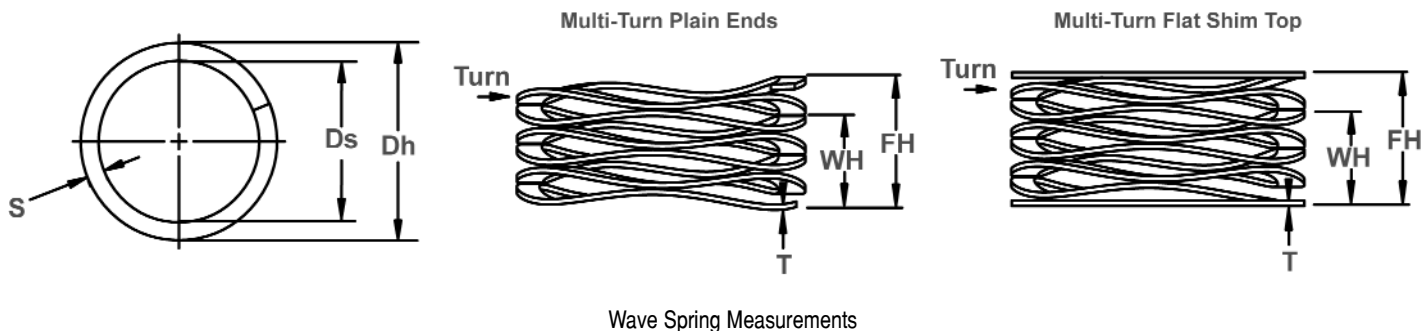

Wave Spring Measurements

WAVE SPRING NO.	HOUSING DIAMETER	SHAFT DIAMETER CLEARANCE	LOAD (N)	WORK HEIGHT	FREE HEIGHT Ref.	NUMBER OF WAVES	NUMBER OF TURNS	THICKNESS	SECTION	SPRING RATE Ref. N/mm
	Dh mm	Ds		WH	FH			T	S	
MWL-30 A	30	24	50	3.18	7.62	3.5	3	0.30	2.39	11.25
MWL-30 B	30	24	50	4.22	10.16	3.5	4	0.30	2.39	8.41
MWL-30 C	30	24	50	5.28	12.70	3.5	5	0.30	2.39	6.74
MWL-30 D	30	24	50	6.32	15.24	3.5	6	0.30	2.39	5.61
MWL-30 E	30	24	50	7.39	17.78	3.5	7	0.30	2.39	4.81
MWL-30 F	30	24	50	8.43	20.32	3.5	8	0.30	2.39	4.21
MWL-30 G	30	24	50	9.50	22.86	3.5	9	0.30	2.39	3.74
MWL-30 H	30	24	50	11.61	27.94	3.5	11	0.30	2.39	3.06
MWL-30 I	30	24	50	13.72	33.02	3.5	13	0.30	2.39	2.59
MWM-30 A	30	24	90	3.51	7.62	3.5	3	0.38	2.39	21.87
MWM-30 B	30	24	90	4.70	10.16	3.5	4	0.38	2.39	16.48
MWM-30 C	30	24	90	5.87	12.70	3.5	5	0.38	2.39	13.17
MWM-30 D	30	24	90	7.04	15.24	3.5	6	0.38	2.39	10.97
MWM-30 E	30	24	90	8.20	17.78	3.5	7	0.38	2.39	9.40
MWM-30 F	30	24	90	9.37	20.32	3.5	8	0.38	2.39	8.22
MWM-30 G	30	24	90	10.54	22.86	3.5	9	0.38	2.39	7.31
MWM-30 H	30	24	90	12.90	27.94	3.5	11	0.38	2.39	5.99
MWM-30 I	30	24	90	15.24	33.02	3.5	13	0.38	2.39	5.06
MWR-30 A	30	24	130	4.19	7.62	3.5	3	0.46	2.39	37.91
MWR-30 B	30	24	130	5.59	10.16	3.5	4	0.46	2.39	28.43
MWR-30 C	30	24	130	6.99	12.70	3.5	5	0.46	2.39	22.75
MWR-30 D	30	24	130	8.38	15.24	3.5	6	0.46	2.39	18.96
MWR-30 E	30	24	130	9.78	17.78	3.5	7	0.46	2.39	16.25
MWR-30 F	30	24	130	11.18	20.32	3.5	8	0.46	2.39	14.22
MWR-30 G	30	24	130	12.57	22.86	3.5	9	0.46	2.39	12.64
MWR-30 H	30	24	130	15.37	27.94	3.5	11	0.46	2.39	10.34
MWR-30 I	30	24	130	18.16	33.02	3.5	13	0.46	2.39	8.75
MWL-35 A	35	27	70	3.94	8.38	3.5	3	0.36	3.18	15.75
MWL-35 B	35	27	70	5.23	11.18	3.5	4	0.36	3.18	11.78
MWL-35 C	35	27	70	6.55	13.97	3.5	5	0.36	3.18	9.44
MWL-35 D	35	27	70	7.87	16.76	3.5	6	0.36	3.18	7.87
MWL-35 E	35	27	70	9.17	19.56	3.5	7	0.36	3.18	6.74
MWL-35 F	35	27	70	10.49	22.35	3.5	8	0.36	3.18	5.90
MWL-35 G	35	27	70	11.81	25.15	3.5	9	0.36	3.18	5.25
MWL-35 H	35	27	70	14.43	30.73	3.5	11	0.36	3.18	4.29
MWL-35 I	35	27	70	17.04	36.32	3.5	13	0.36	3.18	3.63

ALL DIMENSIONS IN MILLIMETERS UNLESS OTHERWISE SPECIFIED.

PART NUMBERS SHOWN REFLECT MULTI-TURN WAVE SPRINGS WITH PLAIN ENDS.

THE LETTERS SHOWN AFTER THE PART NUMBERS REPRESENT THE NUMBER OF TURNS. WHEN ORDERING, PARTS SHOULD BE PRESENTED WITH THE PART NUMBER, FOLLOWED BY THE MATERIAL, AND THEN THE NUMBER OF TURNS (i.e. MWL-8ST A, MWM-10ST B, MWR-14ST C, ETC.)

FOR FLAT SHIM TOP WAVE SPRINGS, ADD AN 'F' TO THE END OF THE PART NUMBER (i.e. MWL-8ST AF, MWM-10ST BF, MWR-14ST CF, ETC.)

MATERIAL CODES: ST = CARBON STEEL. SQ = 17-7 PH/C STAINLESS STEEL. SPECIAL ALLOYS AVAILABLE UPON REQUEST.

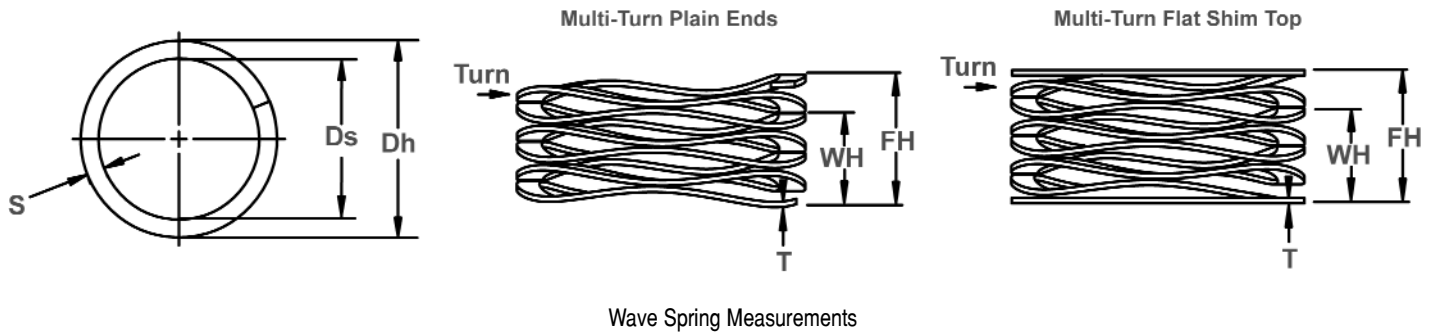

Wave Spring Measurements

WAVE SPRING NO.	HOUSING DIAMETER	SHAFT DIAMETER CLEARANCE	LOAD (N)	WORK HEIGHT	FREE HEIGHT Ref.	NUMBER OF WAVES	NUMBER OF TURNS	THICKNESS	SECTION	SPRING RATE Ref. N/mm
	Dh mm	Ds		WH	FH			T	S	
MWM-35 A	35	27	110	4.14	8.38	3.5	3	0.41	3.38	25.93
MWM-35 B	35	27	110	5.51	11.18	3.5	4	0.41	3.38	19.42
MWM-35 C	35	27	110	6.88	13.97	3.5	5	0.41	3.38	15.52
MWM-35 D	35	27	110	8.26	16.76	3.5	6	0.41	3.38	12.93
MWM-35 E	35	27	110	9.63	19.56	3.5	7	0.41	3.38	11.08
MWM-35 F	35	27	110	11.02	22.35	3.5	8	0.41	3.38	9.71
MWM-35 G	35	27	110	12.40	25.15	3.5	9	0.41	3.38	8.63
MWM-35 H	35	27	110	15.14	30.73	3.5	11	0.41	3.38	7.05
MWM-35 I	35	27	110	17.91	36.32	3.5	13	0.41	3.38	5.97
MWR-35 A	35	27	160	4.04	8.38	3.5	3	0.46	3.38	36.84
MWR-35 B	35	27	160	5.38	11.18	3.5	4	0.46	3.38	27.63
MWR-35 C	35	27	160	6.73	13.97	3.5	5	0.46	3.38	22.10
MWR-35 D	35	27	160	8.08	16.76	3.5	6	0.46	3.38	18.42
MWR-35 E	35	27	160	9.42	19.56	3.5	7	0.46	3.38	15.79
MWR-35 F	35	27	160	10.77	22.35	3.5	8	0.46	3.38	13.81
MWR-35 G	35	27	160	12.12	25.15	3.5	9	0.46	3.38	12.28
MWR-35 H	35	27	160	14.81	30.73	3.5	11	0.46	3.38	10.05
MWR-35 I	35	27	160	17.50	36.32	3.5	13	0.46	3.38	8.50
MWL-40 A	40	30	100	2.90	9.14	3.5	3	0.41	3.38	16.00
MWL-40 B	40	30	100	3.86	12.19	3.5	4	0.41	3.38	12.00
MWL-40 C	40	30	100	4.80	15.24	3.5	5	0.41	3.38	9.58
MWL-40 D	40	30	100	5.77	18.29	3.5	6	0.41	3.38	7.99
MWL-40 E	40	30	100	6.73	21.34	3.5	7	0.41	3.38	6.85
MWL-40 F	40	30	100	7.70	24.38	3.5	8	0.41	3.38	5.99
MWL-40 G	40	30	100	8.66	27.43	3.5	9	0.41	3.38	5.33
MWL-40 H	40	30	100	10.59	33.53	3.5	11	0.41	3.38	4.36
MWL-40 I	40	30	100	12.52	39.62	3.5	13	0.41	3.38	3.69
MWM-40 A	40	30	150	5.44	9.14	3.5	3	0.53	3.63	40.45
MWM-40 B	40	30	150	7.24	12.19	3.5	4	0.53	3.63	30.28
MWM-40 C	40	30	150	9.04	15.24	3.5	5	0.53	3.63	24.20
MWM-40 D	40	30	150	10.85	18.29	3.5	6	0.53	3.63	20.16
MWM-40 E	40	30	150	12.65	21.34	3.5	7	0.53	3.63	17.27
MWM-40 F	40	30	150	14.48	24.38	3.5	8	0.53	3.63	15.14
MWM-40 G	40	30	150	16.28	27.43	3.5	9	0.53	3.63	13.45
MWM-40 H	40	30	150	19.89	33.53	3.5	11	0.53	3.63	11.00
MWM-40 I	40	30	150	23.50	39.62	3.5	13	0.53	3.63	9.30

ALL DIMENSIONS IN MILLIMETERS UNLESS OTHERWISE SPECIFIED.

PART NUMBERS SHOWN REFLECT MULTI-TURN WAVE SPRINGS WITH PLAIN ENDS.

THE LETTERS SHOWN AFTER THE PART NUMBERS REPRESENT THE NUMBER OF TURNS. WHEN ORDERING, PARTS SHOULD BE PRESENTED WITH THE PART NUMBER, FOLLOWED BY THE MATERIAL, AND THEN THE NUMBER OF TURNS (i.e. MWL-8ST A, MWM-10ST B, MWR-14ST C, ETC.)

FOR FLAT SHIM TOP WAVE SPRINGS, ADD AN 'F' TO THE END OF THE PART NUMBER (i.e. MWL-8ST AF, MWM-10ST BF, MWR-14ST CF, ETC.)

MATERIAL CODES: ST = CARBON STEEL. SQ = 17-7 PH/C STAINLESS STEEL. SPECIAL ALLOYS AVAILABLE UPON REQUEST.

MWL, MWM, MWR Wave Springs

Multi Turn, Metric

Used for low force applications with large deflections:
More turns equals less force. Utilizes nearly half the space as
helical compression springs while producing the same force.

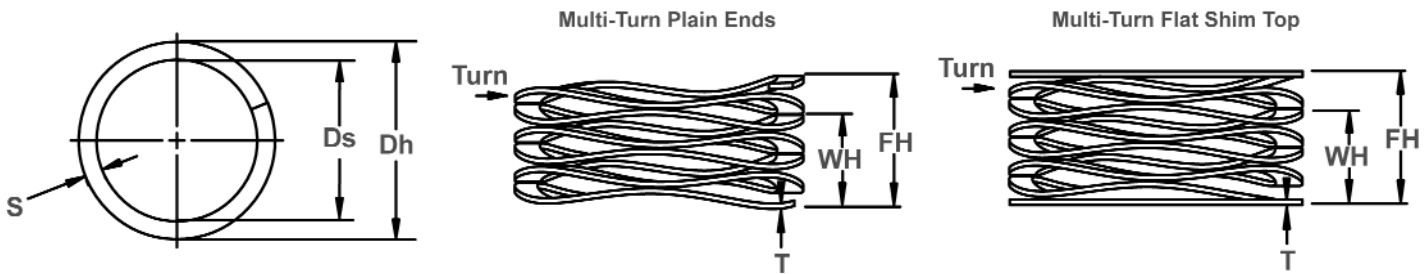

Wave Spring Measurements

WAVE SPRING NO.	HOUSING DIAMETER		SHAFT DIAMETER CLEARANCE	LOAD (N)	WORK HEIGHT	FREE HEIGHT Ref.	NUMBER OF WAVES	NUMBER OF TURNS	THICKNESS	SECTION	SPRING RATE Ref. N/mm
	Dh mm	Ds									
MWR-40 A	40	30	300	5.66	9.14	4.5	3	0.46	3.38	86.21	
MWR-40 B	40	30	300	7.54	12.19	4.5	4	0.46	3.38	64.54	
MWR-40 C	40	30	300	9.42	15.24	4.5	5	0.46	3.38	51.58	
MWR-40 D	40	30	300	11.33	18.29	4.5	6	0.46	3.38	43.11	
MWR-40 E	40	30	300	13.21	21.34	4.5	7	0.46	3.38	36.91	
MWR-40 F	40	30	300	15.09	24.38	4.5	8	0.46	3.38	32.27	
MWR-40 G	40	30	300	16.97	27.43	4.5	9	0.46	3.38	28.67	
MWR-40 H	40	30	300	20.75	33.53	4.5	11	0.46	3.38	23.48	
MWR-40 I	40	30	300	24.54	39.62	4.5	13	0.46	3.38	19.88	
MWL-45 A	45	35	110	3.38	9.91	3.5	3	0.46	3.63	16.85	
MWL-45 B	45	35	110	4.52	13.21	3.5	4	0.46	3.63	12.66	
MWL-45 C	45	35	110	5.64	16.51	3.5	5	0.46	3.63	10.12	
MWL-45 D	45	35	110	6.76	19.81	3.5	6	0.46	3.63	8.43	
MWL-45 E	45	35	110	7.90	23.11	3.5	7	0.46	3.63	7.23	
MWL-45 F	45	35	110	9.02	26.42	3.5	8	0.46	3.63	6.32	
MWL-45 G	45	35	110	10.16	29.72	3.5	9	0.46	3.63	5.62	
MWL-45 H	45	35	110	12.40	36.32	3.5	11	0.46	3.63	4.60	
MWL-45 I	45	35	110	14.66	42.93	3.5	13	0.46	3.63	3.89	
MWM-45 A	45	35	225	5.33	9.91	4.5	3	0.46	3.63	49.21	
MWM-45 B	45	35	225	6.99	13.21	4.5	4	0.46	3.63	36.16	
MWM-45 C	45	35	225	9.14	16.51	4.5	5	0.46	3.63	30.55	
MWM-45 D	45	35	225	10.80	19.81	4.5	6	0.46	3.63	24.95	
MWM-45 E	45	35	225	12.70	23.11	4.5	7	0.46	3.63	21.61	
MWM-45 F	45	35	225	14.48	26.42	4.5	8	0.46	3.63	18.85	
MWM-45 G	45	35	225	16.26	29.72	4.5	9	0.46	3.63	16.71	
MWM-45 H	45	35	225	19.81	36.32	4.5	11	0.46	3.63	13.63	
MWM-45 I	45	35	225	23.37	42.93	4.5	13	0.46	3.63	11.50	
MWR-45 A	45	35	400	6.43	9.91	4.5	3	0.61	3.76	114.95	
MWR-45 B	45	35	400	8.38	13.21	4.5	4	0.61	3.76	82.88	
MWR-45 C	45	35	400	11.20	16.51	4.5	5	0.61	3.76	75.35	
MWR-45 D	45	35	400	12.95	19.81	4.5	6	0.61	3.76	58.33	
MWR-45 E	45	35	400	15.37	23.11	4.5	7	0.61	3.76	51.63	
MWR-45 F	45	35	400	17.27	26.42	4.5	8	0.61	3.76	43.74	
MWR-45 G	45	35	400	19.68	29.72	4.5	9	0.61	3.76	39.87	
MWR-45 H	45	35	400	24.26	36.32	4.5	11	0.61	3.76	33.15	
MWR-45 I	45	35	400	28.45	42.93	4.5	13	0.61	3.76	27.63	

ALL DIMENSIONS IN MILLIMETERS UNLESS OTHERWISE SPECIFIED.

PART NUMBERS SHOWN REFLECT MULTI-TURN WAVE SPRINGS WITH PLAIN ENDS.

THE LETTERS SHOWN AFTER THE PART NUMBERS REPRESENT THE NUMBER OF TURNS. WHEN ORDERING, PARTS SHOULD BE PRESENTED WITH THE PART NUMBER, FOLLOWED BY THE MATERIAL, AND THEN THE NUMBER OF TURNS (i.e. MWL-8ST A, MWM-10ST B, MWR-14ST C, ETC.)

FOR FLAT SHIM TOP WAVE SPRINGS, ADD AN 'F' TO THE END OF THE PART NUMBER (i.e. MWL-8ST AF, MWM-10ST BF, MWR-14ST CF, ETC.)

MATERIAL CODES: ST = CARBON STEEL. SQ = 17-7 PH/C STAINLESS STEEL. SPECIAL ALLOYS AVAILABLE UPON REQUEST.

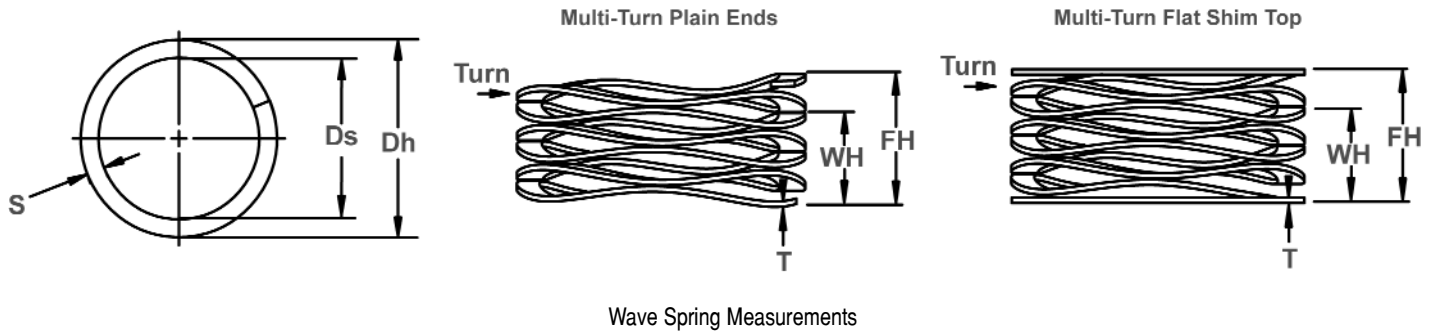

WAVE SPRING NO.	HOUSING DIAMETER		SHAFT DIAMETER CLEARANCE	LOAD (N)	WORK HEIGHT	FREE HEIGHT Ref.	NUMBER OF WAVES	NUMBER OF TURNS	THICKNESS	SECTION	SPRING RATE Ref. N/mm
	Dh mm	Ds									
MWL-50 A	50	40	40	110	4.83	10.29	3.5	3	0.53	3.63	20.14
MWL-50 B	50	40	40	110	6.10	13.72	3.5	4	0.53	3.63	14.44
MWL-50 C	50	40	40	110	7.87	17.15	3.5	5	0.53	3.63	11.86
MWL-50 D	50	40	40	110	9.40	20.57	3.5	6	0.53	3.63	9.84
MWL-50 E	50	40	40	110	11.30	24.00	3.5	7	0.53	3.63	8.66
MWL-50 F	50	40	40	110	12.70	27.43	3.5	8	0.53	3.63	7.47
MWL-50 G	50	40	40	110	14.99	30.86	3.5	9	0.53	3.63	6.93
MWL-50 H	50	40	40	110	18.16	37.72	3.5	11	0.53	3.63	5.62
MWL-50 I	50	40	40	110	21.34	44.58	3.5	13	0.53	3.63	4.73
MWL-50 J	50	40	40	110	24.64	51.44	3.5	15	0.53	3.63	4.10
MWM-50 A	50	40	40	225	4.62	10.29	4.5	3	0.46	3.63	39.72
MWM-50 B	50	40	40	225	6.35	13.72	4.5	4	0.46	3.63	30.55
MWM-50 C	50	40	40	225	7.49	17.15	4.5	5	0.46	3.63	23.31
MWM-50 D	50	40	40	225	8.89	20.57	4.5	6	0.46	3.63	19.26
MWM-50 E	50	40	40	225	10.54	24.00	4.5	7	0.46	3.63	16.71
MWM-50 F	50	40	40	225	11.89	27.43	4.5	8	0.46	3.63	14.47
MWM-50 G	50	40	40	225	13.59	30.86	4.5	9	0.46	3.63	13.03
MWM-50 H	50	40	40	225	16.71	37.72	4.5	11	0.46	3.63	10.71
MWM-50 I	50	40	40	225	19.61	44.58	4.5	13	0.46	3.63	9.01
MWM-50 J	50	40	40	225	22.48	51.44	4.5	15	0.46	3.63	7.77
MWR-50 A	50	40	40	400	5.92	10.29	4.5	3	0.61	3.76	91.56
MWR-50 B	50	40	40	400	7.80	13.72	4.5	4	0.61	3.76	67.59
MWR-50 C	50	40	40	400	10.16	17.15	4.5	5	0.61	3.76	57.27
MWR-50 D	50	40	40	400	11.79	20.57	4.5	6	0.61	3.76	45.51
MWR-50 E	50	40	40	400	14.15	24.00	4.5	7	0.61	3.76	40.59
MWR-50 F	50	40	40	400	15.62	27.43	4.5	8	0.61	3.76	33.87
MWR-50 G	50	40	40	400	17.91	30.86	4.5	9	0.61	3.76	30.88
MWR-50 H	50	40	40	400	21.54	37.72	4.5	11	0.61	3.76	24.72
MWR-50 I	50	40	40	400	25.65	44.58	4.5	13	0.61	3.76	21.14
MWR-50 J	50	40	40	400	29.21	51.44	4.5	15	0.61	3.76	18.00
MWL-55 A	55	45	45	125	5.59	11.05	3.5	3	0.61	3.76	22.89
MWL-55 B	55	45	45	125	7.72	14.73	3.5	4	0.61	3.76	17.83
MWL-55 C	55	45	45	125	9.68	18.41	3.5	5	0.61	3.76	14.31
MWL-55 D	55	45	45	125	11.48	22.1	3.5	6	0.61	3.76	11.77
MWL-55 E	55	45	45	125	13.92	25.78	3.5	7	0.61	3.76	10.54
MWL-55 F	55	45	45	125	15.52	29.46	3.5	8	0.61	3.76	8.96
MWL-55 G	55	45	45	125	18.41	33.15	3.5	9	0.61	3.76	8.48
MWL-55 H	55	45	45	125	21.67	40.51	3.5	11	0.61	3.76	6.63
MWL-55 I	55	45	45	125	25.65	47.88	3.5	13	0.61	3.76	5.62
MWL-55 J	55	45	45	125	29.77	55.25	3.5	15	0.61	3.76	4.91
MWM-55 A	55	45	45	250	3.1	11.05	4.5	3	0.46	3.63	31.45
MWM-55 B	55	45	45	250	4.11	14.73	4.5	4	0.46	3.63	23.55
MWM-55 C	55	45	45	250	5.16	18.41	4.5	5	0.46	3.63	18.86
MWM-55 D	55	45	45	250	6.2	22.1	4.5	6	0.46	3.63	15.72
MWM-55 E	55	45	45	250	7.21	25.78	4.5	7	0.46	3.63	13.46

ALL DIMENSIONS IN MILLIMETERS UNLESS OTHERWISE SPECIFIED.

PART NUMBERS SHOWN REFLECT MULTI-TURN WAVE SPRINGS WITH PLAIN ENDS.

THE LETTERS SHOWN AFTER THE PART NUMBERS REPRESENT THE NUMBER OF TURNS. WHEN ORDERING, PARTS SHOULD BE PRESENTED WITH THE PART NUMBER, FOLLOWED BY THE MATERIAL, AND THEN THE NUMBER OF TURNS (i.e. MWL-8ST A, MWM-10ST B, MWR-14ST C, ETC.)

FOR FLAT SHIM TOP WAVE SPRINGS, ADD AN 'F' TO THE END OF THE PART NUMBER (i.e. MWL-8ST AF, MWM-10ST BF, MWR-14ST CF, ETC.)

MATERIAL CODES: ST = CARBON STEEL. SQ = 17-7 PH/C STAINLESS STEEL. SPECIAL ALLOYS AVAILABLE UPON REQUEST.

MWL, MWM, MWR Wave Springs

Multi Turn, Metric

Used for low force applications with large deflections:
More turns equals less force. Utilizes nearly half the space as
helical compression springs while producing the same force.

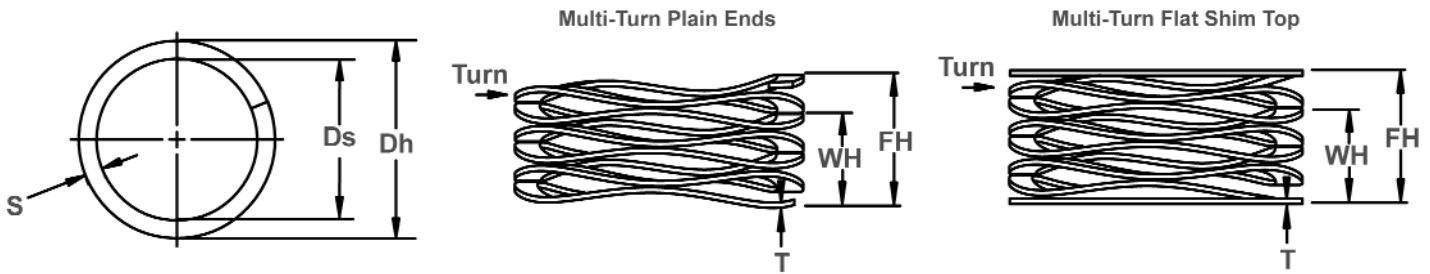

Wave Spring Measurements

WAVE SPRING NO.	HOUSING DIAMETER		SHAFT DIAMETER CLEARANCE	LOAD (N)	WORK HEIGHT		FREE HEIGHT Ref.	NUMBER OF WAVES	NUMBER OF TURNS	THICKNESS	SECTION	SPRING RATE Ref. N/mm
	Dh mm	Ds			T	S						
MWM-55 F	55	45	45	250	8.26	29.46	4.5	8	0.46	3.63	11.79	
MWM-55 G	55	45	45	250	9.27	33.15	4.5	9	0.46	3.63	10.47	
MWM-55 H	55	45	45	250	11.33	40.51	4.5	11	0.46	3.63	8.57	
MWM-55 I	55	45	45	250	13.41	47.88	4.5	13	0.46	3.63	7.25	
MWM-55 J	55	45	45	250	15.47	55.25	4.5	15	0.46	3.63	6.29	
MWR-55 A	55	45	45	400	5.31	11.05	4.5	3	0.61	3.76	69.68	
MWR-55 B	55	45	45	400	7.24	14.73	4.5	4	0.61	3.76	53.38	
MWR-55 C	55	45	45	400	9.09	18.41	4.5	5	0.61	3.76	42.91	
MWR-55 D	55	45	45	400	10.64	22.1	4.5	6	0.61	3.76	34.92	
MWR-55 E	55	45	45	400	12.24	25.78	4.5	7	0.61	3.76	29.55	
MWR-55 F	55	45	45	400	14.1	29.46	4.5	8	0.61	3.76	26.03	
MWR-55 G	55	45	45	400	15.82	33.15	4.5	9	0.61	3.76	23.09	
MWR-55 H	55	45	45	400	19.3	40.51	4.5	11	0.61	3.76	18.86	
MWR-55 I	55	45	45	400	23.11	47.88	4.5	13	0.61	3.76	16.15	
MWR-55 J	55	45	45	400	26.54	55.25	4.5	15	0.61	3.76	13.94	
MWL-60 A	60	50	50	135	5.59	11.43	4.5	3	0.46	3.63	23.11	
MWL-60 B	60	50	50	135	7.47	15.24	4.5	4	0.46	3.63	17.37	
MWL-60 C	60	50	50	135	9.32	19.05	4.5	5	0.46	3.63	13.88	
MWL-60 D	60	50	50	135	11.2	22.86	4.5	6	0.46	3.63	11.58	
MWL-60 E	60	50	50	135	13.06	26.67	4.5	7	0.46	3.63	9.92	
MWL-60 F	60	50	50	135	14.94	30.48	4.5	8	0.46	3.63	8.68	
MWL-60 G	60	50	50	135	16.79	34.29	4.5	9	0.46	3.63	7.71	
MWL-60 H	60	50	50	135	20.52	41.91	4.5	11	0.46	3.63	6.31	
MWL-60 I	60	50	50	135	24.26	49.53	4.5	13	0.46	3.63	5.34	
MWL-60 J	60	50	50	135	27.99	57.15	4.5	15	0.46	3.63	4.63	
MWM-60 A	60	50	50	275	6.65	11.43	4.5	3	0.61	3.76	57.59	
MWM-60 B	60	50	50	275	8.86	15.24	4.5	4	0.61	3.76	43.13	
MWM-60 C	60	50	50	275	11.07	19.05	4.5	5	0.61	3.76	34.48	
MWM-60 D	60	50	50	275	13.28	22.86	4.5	6	0.61	3.76	28.72	
MWM-60 E	60	50	50	275	15.49	26.67	4.5	7	0.61	3.76	24.61	
MWM-60 F	60	50	50	275	17.7	30.48	4.5	8	0.61	3.76	21.52	
MWM-60 G	60	50	50	275	19.94	34.29	4.5	9	0.61	3.76	19.16	
MWM-60 H	60	50	50	275	24.36	41.91	4.5	11	0.61	3.76	15.67	
MWM-60 I	60	50	50	275	28.78	49.53	4.5	13	0.61	3.76	13.25	
MWM-60 J	60	50	50	275	33.22	57.15	4.5	15	0.61	3.76	11.49	
MWR-60 A	60	50	50	450	7.75	11.43	4.5	3	0.76	4.01	122.18	
MWR-60 B	60	50	50	450	10.31	15.24	4.5	4	0.76	4.01	91.32	
MWR-60 C	60	50	50	450	12.9	19.05	4.5	5	0.76	4.01	73.21	
MWR-60 D	60	50	50	450	15.47	22.86	4.5	6	0.76	4.01	60.88	
MWR-60 E	60	50	50	450	18.06	26.67	4.5	7	0.76	4.01	52.26	
MWR-60 F	60	50	50	450	20.62	30.48	4.5	8	0.76	4.01	45.66	
MWR-60 G	60	50	50	450	23.22	34.29	4.5	9	0.76	4.01	40.63	
MWR-60 H	60	50	50	450	28.37	41.91	4.5	11	0.76	4.01	33.24	
MWR-60 I	60	50	50	450	33.53	49.53	4.5	13	0.76	4.01	28.12	
MWR-60 J	60	50	50	450	38.68	57.15	4.5	15	0.76	4.01	24.37	

ALL DIMENSIONS IN MILLIMETERS UNLESS OTHERWISE SPECIFIED.

PART NUMBERS SHOWN REFLECT MULTI-TURN WAVE SPRINGS WITH PLAIN ENDS.

THE LETTERS SHOWN AFTER THE PART NUMBERS REPRESENT THE NUMBER OF TURNS. WHEN ORDERING, PARTS SHOULD BE PRESENTED WITH THE PART NUMBER, FOLLOWED BY THE MATERIAL, AND THEN THE NUMBER OF TURNS (i.e. MWL-8ST A, MWM-10ST B, MWR-14ST C, ETC.)

FOR FLAT SHIM TOP WAVE SPRINGS, ADD AN 'F' TO THE END OF THE PART NUMBER (i.e. MWL-8ST AF, MWM-10ST BF, MWR-14ST CF, ETC.)

MATERIAL CODES: ST = CARBON STEEL. SQ = 17-7 PH/C STAINLESS STEEL. SPECIAL ALLOYS AVAILABLE UPON REQUEST.

Shims

Shims are typically used in order to support, adjust for better fit, or provide a level surface. Shims may also be used as spacers to fill gaps between parts subject to wear.

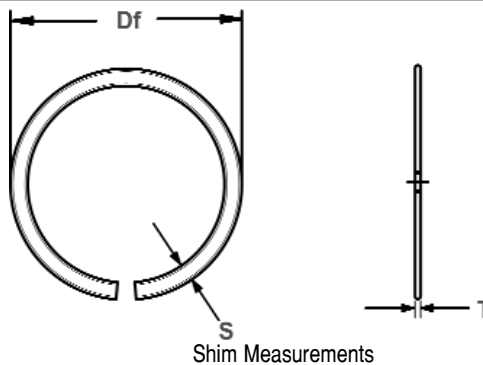

Shim Measurements

RING NO.	RING SIZE			
	FREE DIAMETER		THICKNESS	SECTION
	Df	Tol.	T	S
KMS-75	0.750	+.000 -.015	.024	.093
KMS-87	0.875		.024	.093
KMS-100	1.000		.024	.103
KMS-112	1.125		.024	.138
KMS-125	1.250		.024	.138
KMS-137	1.375		.024	.138
KMS-150	1.500	+.000 -.020	.024	.150
KMS-162	1.625		.024	.150
KMS-175	1.750		.024	.150
KMS-187	1.875		.024	.150
KMS-200	2.000		.024	.150
KMS-212	2.125		.024	.150
KMS-225	2.250	+.000 -.025	.024	.150
KMS-237	2.375		.024	.178
KMS-250	2.500		.024	.178
KMS-262	2.625		.024	.178
KMS-275	2.750		.030	.188
KMS-287	2.875		.030	.188
KMS-300	3.000	+.000 -.030	.030	.188
KMS-312	3.125		.030	.188
KMS-325	3.250		.030	.233
KMS-337	3.375		.030	.233
KMS-350	3.500		.030	.233
KMS-362	3.625		.030	.233
KMS-375	3.750	+.000 -.035	.030	.233
KMS-387	3.875		.030	.233
KMS-400	4.000		.030	.233
KMS-412	4.125		.030	.233
KMS-425	4.250		.030	.233
KMS-437	4.375		.030	.233
KMS-450	4.500	+.000 -.090	.030	.233
KMS-462	4.625		.030	.233
KMS-475	4.750		.030	.233
KMS-487	4.875		.030	.233
KMS-500	5.000		.030	.233

RING NO.	RING SIZE			
	FREE DIAMETER		THICKNESS	SECTION
	Df	Tol.	T	S
KMS-512	5.125	+.000	.030	.233
KMS-525	5.250	-.035	.030	.233
KMS-537	5.375	+.000 -.045	.030	.233
KMS-550	5.500		.030	.233
KMS-562	5.625		.030	.233
KMS-575	5.750		.030	.233
KMS-587	5.875		.030	.233
KMS-600	6.000		.030	.233
KMS-612	6.125	+.000 -.060	.030	.233
KMS-625	6.250		.030	.233
KMS-637	6.375		.030	.233
KMS-650	6.500		.030	.233
KMS-675	6.750		.030	.233
KMS-700	7.000		.032	.375
KMS-725	7.250	+.000 -.070	.032	.375
KMS-750	7.500		.032	.375
KMS-775	7.750		.032	.375
KMS-800	8.000		.032	.375
KMS-825	8.250		.032	.375
KMS-850	8.500		.032	.375
KMS-900	9.000	+.000 -.080	.032	.375
KMS-950	9.500		.032	.375
KMS-1000	10.000		.032	.375
KMS-1050	10.500		.032	.375
KMS-1100	11.000		.032	.375
KMS-1150	11.500		.032	.375
KMS-1200	12.000	+.000 -.090	.032	.375
KMS-1250	12.500		.032	.375
KMS-1300	13.000		.032	.375
KMS-1350	13.500		.032	.375
KMS-1400	14.000		.032	.375
KMS-1450	14.500		.032	.375
KMS-1500	15.000	+.000 -.090	.032	.375
KMS-1550	15.500		.032	.375
KMS-1600	16.000	.032	.375	



HC Hose Clamps

Single Wire, Self-Compensating Hose Clamp

Single wire clamps have the most effective holding force and clamping strength. The single wire concentrates the clamping force in one specific area around the hose.

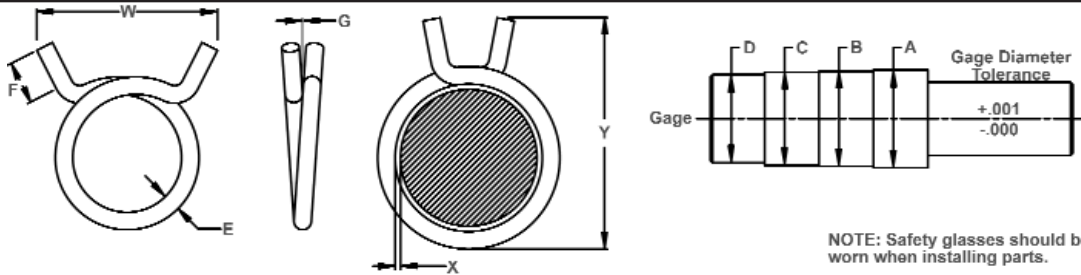

NOTE: Safety glasses should be worn when installing parts.

EFFECTIVE CLAMPING RANGE: After expanding to no greater than "A" diameter of the gage, the clamp in relaxed condition shall not pass over "D" diameter. When clamp is assembled on the "A", "B" or "C" diameter of gage, a wire of "X" diameter shall not pass between gage and clamp when inserted in a direction parallel to the axis of the gage.

FINISH: Peen-Plate Zinc (non-electrolytic process) .0002 minimum thickness plus dichromate treatment. (See color codes below.)

MATERIAL: Specially processed premium grade spring wire, hardened and austempered to meet the performance requirements specified.

Note: All Dimensions are in Inches. Conforms to SAE spec. J1508.

ROTOR CLAMP HC NO.	Case Quantity	Approx. Case Weight (lbs.)	EFFECTIVE CLAMPING RANGE				E Nom. Wire Dia.	F Length of Tangs	G Clearance at overlap Max.	W Width over Tangs Max.	X Gaging Wire Max.	Y Overall Height (Ref. Only)	Color Code *	Pneumatic Installation Tool	
			A Max. Dia.	B Nom. Dia.	C Min. Dia.	D No-Go Gage Dia.									
19N	HC-4	15000	25.7	.253	.250	.247	.233	.062	3/8	.010	.75	.003	.88	G	PWS-4
	HC-5	10000	18.6	.315	.312	.309	.286	.062	3/8	.010	.75	.003	1.00	R	PWS-5
	HC-5.5	10000	19.8	.345	.342	.339	.320	.062	3/8	.010	.75	.003	1.00	G	PWS-5.5
35N	HC-6	10000	37.9	.380	.375	.370	.350	.082	3/8	.015	.88	.004	1.06	D	PWS-6
	HC-7	8000	38.9	.442	.437	.432	.405	.087	3/8	.015	.94	.004	1.12	G	PWS-7
	HC-7.5	7500	37.5	.473	.468	.463	.430	.087	3/8	.015	1.00	.005	1.12	D	PWS-7.5
	HC-8	6000	33.7	.510	.500	.490	.462	.092	3/8	.025	1.00	.005	1.19	R	PWS-8
	HC-8.5	6000	34.8	.541	.531	.521	.492	.092	3/8	.025	1.00	.005	1.38	G	PWS-8.5
	HC-9	4500	38.0	.573	.562	.551	.520	.107	3/8	.025	1.06	.006	1.38	D	PWS-9
	HC-9.5	4500	39.0	.604	.593	.582	.550	.107	3/8	.025	1.06	.006	1.38	R	PWS-9.5
	HC-10	4000	34.8	.640	.625	.610	.580	.107	3/8	.025	1.06	.006	1.38	G	PWS-10
	HC-10.5	4000	37.6	.671	.656	.641	.611	.107	3/8	.025	1.06	.006	1.38	D	PWS-10.5
	HC-11	3500	37.0	.703	.687	.671	.635	.112	3/8	.025	1.12	.006	1.50	R	PWS-11
	HC-12	3000	33.0	.770	.750	.730	.690	.112	3/8	.031	1.19	.008	1.50	D	PWS-12
	HC-13	2500	30.7	.832	.812	.792	.740	.117	3/8	.031	1.25	.008	1.50	G	PWS-13
HC-14	2000	28.2	.900	.875	.850	.800	.122	3/8	.031	1.25	.008	1.62	R	PWS-14	
HC-15	2000	31.0	.968	.937	.906	.855	.122	3/8	.062	1.25	.008	1.69	D	PWS-15	
HC-16	1750	32.9	1.031	1.000	.969	.915	.132	3/8	.062	1.31	.008	1.75	G	PWS-16	
HC-17	1400	32.6	1.090	1.062	1.034	.960	.142	3/8	.062	1.50	.010	1.88	R	PWS-17	
HC-17.5	1250	32.5	1.124	1.093	1.065	.991	.152	3/8	.062	1.50	.010	1.90	R	PWS-17.5	
HC-18	1000	28.0	1.150	1.125	1.100	1.030	.152	3/8	.062	1.62	.010	2.00	D	PWS-18	
HC-188	1500	26.4	1.150	1.125	1.100	1.030	.122	3/8	.062	1.62	.010	2.00	D	PWS-188	
HC-19	1000	28.3	1.218	1.187	1.156	1.095	.152	3/8	.062	1.62	.010	2.00	G	PWS-19	
HC-19.5	1000	29.3	1.250	1.218	1.187	1.126	.152	3/8	.062	1.63	.010	2.00	R	PWS-19.5	
HC-20	1000	30.0	1.280	1.250	1.219	1.145	.152	3/8	.062	1.75	.010	2.00	R	PWS-20	
HC-21	800	28.8	1.344	1.312	1.281	1.210	.162	3/8	.062	1.75	.010	2.31	D	PWS-21	
HC-22	800	29.6	1.406	1.375	1.344	1.250	.162	3/8	.062	1.88	.010	2.31	G	PWS-22	
HC-23	750	25.5	1.468	1.437	1.406	1.300	.162	3/8	.062	1.88	.010	2.31	R	PWS-23	
HC-24	600	23.4	1.531	1.500	1.469	1.350	.162	3/8	.062	1.88	.010	2.38	D	PWS-24	
HC-25	600	23.6	1.592	1.561	1.530	1.411	.162	3/8	.062	1.88	.010	2.53	D	PWS-25	
HC-26	600	28.8	1.672	1.625	1.578	1.455	.172	3/8	.062	2.00	.010	2.69	D	PWS-26	
HC-28	500	25.0	1.797	1.750	1.703	1.550	.172	3/8	.062	2.12	.010	2.75	D	PWS-28	
HC-30	500	29.0	1.937	1.875	1.812	1.675	.177	3/8	.093	2.25	.010	2.88	D	PWS-30	
HC-31	500	29.5	2.000	1.937	1.875	1.720	.177	3/8	.093	2.25	.010	3.00	D	PWS-31	
HC-32	500	30.0	2.061	2.000	1.939	1.750	.177	3/8	.093	2.31	.010	3.00	D	PWS-32	
HC-34	500	31.9	2.187	2.125	2.062	1.860	.182	3/8	.093	2.31	.010	3.19	D	PWS-34	
HC-35	500	34.2	2.250	2.187	2.125	1.925	.182	3/8	.093	2.31	.010	3.25	D	PWS-35	
HC-36	500	34.5	2.312	2.250	2.187	2.000	.182	3/8	.093	2.38	.010	3.25	D	PWS-36	
HC-38	500	39.5	2.437	2.375	2.312	2.100	.192	3/8	.093	2.38	.010	3.44	D	PWS-38	
HC-40	500	41.5	2.561	2.500	2.439	2.187	.192	3/8	.093	2.38	.010	3.62	D	PWS-40	
HC-42	400	39.2	2.688	2.625	2.562	2.320	.202	3/8	.093	2.38	.010	3.75	D	PWS-42	
HC-46	400	41.9	2.938	2.875	2.812	2.625	.220	3/8	.093	2.63	.012	3.88	D	PWS-46	
HC-50	400	53.8	3.218	3.125	3.032	2.844	.220	3/8	.125	3.12	.013	4.00	D	PWS-50	

* GREEN, R-RED, D-DICHROMATE(YELLOW), NOTE: SELECTED SIZES AVAILABLE IN STAINLESS STEEL. INQUIRE FOR AVAILABILITY.

Slim Wire, Self-Compensating Hose Clamp

A slimmer version of the Single Wire Hose clamp. The single wire concentrates the clamping force in one specific area around the hose. Can be installed with manual and pneumatic tools

HW Hose Clamps



NOTE: Safety glasses should be worn when installing parts.

EFFECTIVE CLAMPING RANGE: After expanding to no greater than "A" diameter of the gage, the clamp in relaxed condition shall not pass over "D" diameter. When clamp is assembled on "A", "B" or "C" diameter of gage, a wire of "X" diameter shall not pass between gage and clamp when inserted in a direction parallel to the axis of the gage.

FINISH: Peen-Plate Zinc (non-electrolytic process) .0002 minimum thickness plus dichromate treatment. (See color codes below.)

MATERIAL: Specially processed premium grade spring wire, hardened and austempered to meet the performance requirements specified.

Note: All Dimensions are in inches.

ROTOR CLAMP HW NO.	Case Quantity Min. 1 case	Approx. Case Weight (lbs.)	E Nom. Wire Dia.	EFFECTIVE CLAMPING RANGE				X Dia. Gaging Wire	G Clearance at overlap Max.	F Length of Tangs	W Width over Tangs Max.	Z Width over Tangs when on a Dia.		Y Overall Height (Ref. Only)	Color Code *	Pneumatic installation Tool	
				A Max. Dia.	B Nom. Dia.	C Min. Dia.	D No-Go Gage Dia.										
HW-9	8000	39	.082	.573	.562	.551	.520	.006	.025	1/4	+ .000-1/32	1-1/16	.415	+ .020-.000	1.25	ZD	PWS-9
HW-11	6000	33	.087	.703	.688	.671	.635	.006	.025	1/4	+ .000-1/32	1-1/8	.425	+ .020-.000	1.38	R	PWS-11
HW-12	5000	30	.087	.770	.750	.730	.690	.008	.031	1/4	+ .000-1/32	1-3/16	.425	+ .020-.000	1.38	ZD	PWS-12
HW-13	4000	28	.092	.832	.812	.792	.740	.008	.031	1/4	+ .000-1/32	1-1/4	.410	+ .020-.000	1.38	G	PWS-13
HW-14	3000	26	.092	.900	.875	.850	.800	.008	.031	1/4	+ .000-1/32	1-1/4	.410	+ .020-.000	1.49	R	PWS-14
HW-16	2500	29	.107	1.031	1.000	.969	.915	.008	.062	1/4	±1/32	1-1/2	.510	+ .020-.000	1.75	G	PWS-16
HW-18	1700	28	.122	1.150	1.125	1.100	1.030	.010	.062	1/4	±1/32	1-5/8	.525	+ .020-.000	1.88	ZD	PWS-18
HW-19	1400	24	.122	1.218	1.187	1.152	1.095	.010	.062	1/4	±1/32	1-5/8	.510	+ .020-.000	1.88	G	PWS-19
HW-20	1400	23	.122	1.280	1.250	1.219	1.145	.010	.062	1/4	±1/32	1-3/4	.525	+ .030-.000	1.88	R	PWS-20
HW-21	1300	28	.132	1.344	1.312	1.281	1.210	.010	.062	1/4	±1/32	1-3/4	.540	+ .030-.000	2.19	ZD	PWS-21
HW-22	1000	22	.132	1.406	1.375	1.344	1.250	.010	.062	1/4	±1/32	1-7/8	.540	+ .030-.000	2.19	G	PWS-22
HW-23	1000	23	.132	1.468	1.437	1.406	1.300	.010	.062	1/4	±1/32	1-7/8	.525	+ .030-.000	2.19	R	PWS-23
HW-24	1000	24	.132	1.531	1.500	1.469	1.350	.010	.062	1/4	+1/16-.000	1-7/8	.540	+ .030-.000	2.25	ZD	PWS-24
HW-26	900	27	.142	1.672	1.625	1.578	1.455	.010	.062	1/4	±1/16	2	.580	+ .030-.000	2.56	ZD	PWS-26

* GREEN, R-RED, ZD-DICHROMATE (YELLOW)





DW Hose Clamps

Double Wire, Self-Compensating Hose Clamp

Double wire clamps are used where a lower clamping force than offered by single wire clamps is sufficient and aesthetics are important. The double wound wire spreads out the clamping force around the hose, and are more cost effective than single wire clamps.

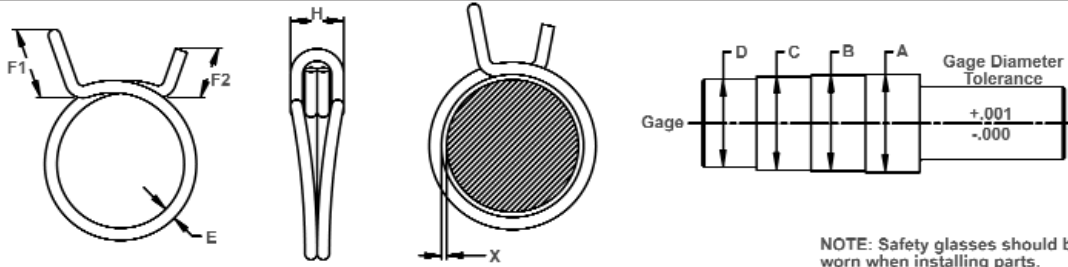

NOTE: Safety glasses should be worn when installing parts.

EFFECTIVE CLAMPING RANGE: After expanding to no greater than "A" diameter of the gage, the clamp in relaxed condition shall not pass over "D" diameter. When clamp is assembled on the "A", "B" or "C" diameter of gage, a wire of "X" diameter shall not pass between gage and clamp when inserted in a direction parallel to the axis of the gage.

FINISH: Peen-Plate Zinc (non-electrolytic process) .0002 minimum thickness plus dichromate treatment. (See color codes below.)

MATERIAL: Specially processed premium grade spring wire, hardened and austempered to meet the performance requirements specified.

Note: All Dimensions are in Inches. Conforms to SAE spec. J1508.

ROTOR CLAMP DW No.	Case Quantity Min. 1 case	Approx. Case Weight (lbs.)	A MAX. Dia.	B NOM. Dia.	C MIN Dia.	D NO-GO GAGE Dia.	E NOM. WIRE Dia.	Ref. Dimensions		H OVER-ALL WIDTH	X GAGING WIRE	Color Code *	PNEUMATIC INSTALLATION TOOL
								F1 max.	F2 min.				
DW-4.5	10000	11	.294	.286	.274	.265	.039	.250	.190	.250	.004	D	PWD-4.5
DW-5	10000	11	.306	.301	.285	.280	.039	.250	.190	.250	.004	D	PWD-5
DW-5.5	10000	12	.345	.342	.339	.320	.039	.250	.190	.250	.004	S	PWD-5.5
DW-6	17000	22	.380	.375	.370	.350	.039	.250	.190	.250	.004	S	PWD-6
DW-6.5	8000	28	.416	.409	.401	.381	.059	.380	.250	.280	.006	D	PWD-6.5
DW-7	7000	26	.442	.438	.432	.405	.059	.380	.250	.280	.006	S	PWD-7
DW-8	7000	28	.510	.500	.490	.462	.059	.380	.250	.280	.006	R	PWD-8
DW-8.5	7000	29	.555	.539	.524	.484	.059	.380	.250	.280	.006	D	PWD-8.5
DW-9	6000	38	.573	.562	.551	.520	.070	.425	.250	.325	.006	S	PWD-9
DW-9.5	2500	34	.627	.614	.595	.555	.070	.425	.250	.325	.006	R	PWD-9.5
DW-10	4000	25	.640	.625	.610	.580	.070	.425	.250	.325	.006	G	PWD-10
DW-10.5	3000	20	.662	.646	.627	.586	.070	.425	.250	.325	.006	D	PWD-10.5
DW-11	2500	23	.703	.688	.671	.635	.078	.500	.325	.360	.008	R	PWD-11
DW-11.5	2500	24	.736	.716	.697	.650	.078	.500	.325	.360	.008	D	PWD-11.5
DW-12	2000	20	.770	.750	.730	.690	.078	.500	.325	.360	.008	S	PWD-12
DW-12.5	2000	21	.812	.795	.772	.720	.078	.500	.325	.360	.008	D	PWD-12.5
DW-13	2000	21	.832	.812	.792	.740	.078	.500	.325	.360	.008	G	PWD-13
DW-14	1500	21	.900	.875	.850	.800	.086	.550	.375	.400	.008	D	PWD-14
DW-14.5	1500	21	.928	.909	.882	.826	.086	.550	.375	.400	.008	R	PWD-14.5
DW-15	1200	17	.968	.938	.906	.855	.086	.550	.375	.400	.008	S	PWD-15
DW-16	1100	22	1.031	1.000	.969	.915	.098	.560	.375	.450	.008	D	PWD-16
DW-17	1000	21	1.090	1.062	1.034	.960	.098	.560	.375	.450	.008	R	PWD-17
DW-17.5	1000	21	1.107	1.082	1.050	.984	.098	.560	.375	.450	.008	D	PWD-17.5
DW-18	1700	37	1.150	1.125	1.100	1.030	.098	.560	.375	.450	.008	S	PWD-18
DW-19	1250	37	1.218	1.188	1.156	1.095	.110	.660	.450	.480	.010	G	PWD-19
DW-19.5	1100	33	1.260	1.232	1.196	1.117	.110	.660	.450	.480	.010	D	PWD-19.5
DW-20	1100	34	1.280	1.250	1.219	1.145	.110	.660	.450	.480	.010	R	PWD-20
DW-21	1100	35	1.344	1.312	1.281	1.210	.110	.660	.450	.480	.010	S	PWD-21
DW-22	1000	39	1.405	1.377	1.335	1.260	.118	.750	.500	.540	.010	G	PWD-22
DW-22.5	900	36	1.433	1.401	1.362	1.279	.118	.750	.500	.540	.010	S	PWD-22.5
DW-23	900	36	1.500	1.465	1.425	1.330	.118	.750	.500	.540	.010	D	PWD-23
DW-24	750	35	1.531	1.500	1.469	1.350	.126	.750	.500	.560	.010	S	PWD-24
DW-25	750	37	1.592	1.561	1.530	1.411	.126	.750	.500	.560	.010	S	PWD-25
DW-26	700	35	1.692	1.625	1.578	1.475	.126	.750	.500	.560	.010	D	PWD-26
DW-27	650	34	1.745	1.688	1.640	1.528	.126	.750	.500	.560	.010	R	PWD-27
DW-28	650	34	1.797	1.750	1.703	1.580	.126	.750	.500	.560	.010	S	PWD-28
DW-30	600	34	1.937	1.875	1.812	1.720	.126	.750	.500	.560	.010	S	PWD-30
DW-31	500	34	2.000	1.938	1.875	1.799	.137	.800	.550	.590	.010	S	PWD-31
DW-32	500	35	2.061	2.000	1.939	1.83	.137	.800	.550	.590	.010	D	PWD-32
DW-34	450	33	2.187	2.125	2.062	1.946	.137	.800	.550	.590	.010	S	PWD-34
DW-35	400	30	2.250	2.187	2.125	1.975	.137	.800	.550	.590	.010	S	PWD-35
DW-36	400	31	2.300	2.250	2.187	2.000	.137	.800	.550	.59	.010	S	PWD-36

* G-Green, R-Red, D-Dichromate (Yellow). NOTE: SELECTED SIZES AVAILABLE IN STAINLESS STEEL. INQUIRE FOR AVAILABILITY.

** MANUAL INSTALLATION TOOLS ALSO AVAILABLE.



Constant Tension Band, Self-Compensating Hose Clamp

Constant Tension Band clamps are used in applications where a lower clamping force than offered by single wire clamps is sufficient, but a higher clamping force than produced by double wire clamps is needed.

CTB Hose Clamps

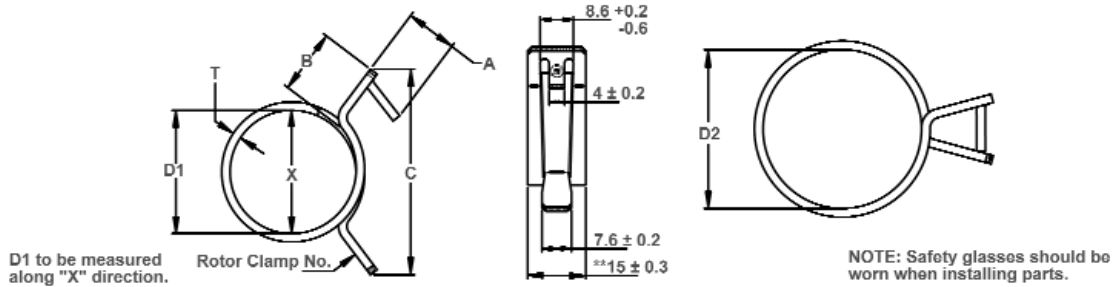

CTB Clamps should be installed/removed using the proper tool.

** Contact manufacturer for availability of additional widths.

Note: Dimensions "D1" and "C" to be measured only after expanding the clamp fully one time.

FINISH: Zinc Rich Paint* up to 700 hour-salt spray.

MATERIAL: SAE 1074 - material code ST, (Optional Material: Chrome Vanadium - DIN 17222, JIS G 4802 - material code CV.)

Note: All Dimensions are in Millimeters. Conforms to SAE spec. J1508.

ROTOR CLAMP CTB NO. (mm)	CASE QUANTITY min 1 case	WEIGHT PER M (lbs.)	WEIGHT PER CASE (lbs.)	D1 Free Dia. Max. (mm)	D2 FULL OPEN DIA. Min. (mm)	MATERIAL THICKNESS T +0.08 -0.02	REFERENCE DIMENSIONS (All Sizes Listed In mm)		
							A (mm) Tab Height	B (mm) Ear Length	C (mm) Ear Span
CTB-13	2500	8.5	21.250	12.0	14.2	0.70	7.3	11.7	27.0
CTB-14	2500	10.2	25.500	13.5	15.3	0.80	8.0	12.5	30.0
CTB-15	2500	9.35	23.375	13.9	16.8	0.70	7.2	11.9	31.0
CTB-16	2500	12.87	32.175	14.4	17.2	1.00	6.6	10.8	28.5
CTB-17	2500	10.8	27.000	15.2	18.5	0.85	7.3	12.5	32.0
CTB-19	1800	20.3	36.540	17.8	20.0	1.30	10.4	12.0	35.0
CTB-20	1700	21.4	36.380	18.4	21.6	1.30	9.1	12.1	32.0
CTB-22	1500	23.2	34.755	20.5	24.5	1.30	8.5	12.5	36.0
CTB-23	1000	27.5	27.500	21.0	24.7	1.50	8.1	12.9	39.0
CTB-24	1250	24.0	29.975	22.0	26.0	1.30	8.1	12.7	36.0
CTB-25	1000	29.5	29.500	23.5	26.8	1.50	9.3	12.4	34.0
CTB-26	1000	31.9	31.900	24.3	28.0	1.60	10.0	12.6	34.0
CTB-27	1000	33.6	33.570	25.2	28.9	1.60	10.1	12.5	38.0
CTB-29	900	38.9	35.010	27.0	31.5	1.73	10.3	13.3	35.0
CTB-30	900	38.2	34.380	28.0	32.5	1.73	11.4	13.4	41.0
CTB-32	700	38.9	27.230	29.3	34.5	1.73	11.7	12.1	44.0
CTB-35	700	44.2	30.940	31.5	38.0	1.73	11.1	15.0	50.0
CTB-36	700	44.4	31.080	32.5	39.0	1.73	11.3	13.3	48.0
CTB-38	600	47.5	28.500	34.5	41.5	1.73	10.2	15.1	52.0
CTB-40	600	47.9	28.740	35.5	42.5	1.73	11.1	13.0	52.0
CTB-42	500	54.0	27.000	37.2	44.5	1.90	10.6	14.7	52.0
CTB-44	500	56.1	28.050	38.5	46.5	1.90	11.0	14.5	53.0
CTB-46	500	61.4	30.675	40.5	48.5	2.00	11.5	14.4	55.0
CTB-47	450	63.5	28.575	41.4	50.0	2.00	13.2	14.3	59.0
CTB-50	450	67.1	30.195	43.5	53.0	2.00	11.3	14.4	59.0
CTB-51	350	67.4	23.590	44.0	54.0	2.00	11.2	15.6	60.0
CTB-53	300	77.8	23.340	46.0	55.8	2.20	11.1	16.5	61.0
CTB-55	250	79.0	19.750	46.8	58.0	2.20	11.3	15.2	65.0
CTB-58	250	85.1	21.275	50.0	61.0	2.25	10.5	14.8	66.0
CTB-61	200	98.9	19.780	54.0	65.0	2.40	12.2	15.0	69.0
CTB-67	175	108.5	18.988	60.0	72.0	2.40	13.1	16.0	78.0

* A Magni 511 finish offers 480 hours salt spray protection per ASTM B117. Is is a chrome-free duplex coating system that combines an inorganic zinc-rich basecoat with an organic topcoat.

Magni 511 meets the following automotive specifications: General Motors: GM7111M, GMW14100; Chrysler: PS-7626;

Ford: S441 (WSS-M21P37-A2); Delphi: DX550041.

Mechanical Zinc is also available along with other finishes. Inquire for more information.



CTN - Constant Tension Band Narrow, Self-Compensating Hose Clamp

CTN's are available in a width of 12mm, and are typically used in places where a standard width CTB band clamp (15mm) is too wide for the application. CTN clamps are suited for applications that would normally require a CTB clamp. Nominal diameters range from 13mm to 90mm. Contact tech@rotorclip.com for more specifications.





CTL Hose Clamps

Constant Tension Light Band, Self-Compensating Hose Clamp

These are cost effective alternatives to other types of band clamps, but do not compromise quality or reliability.

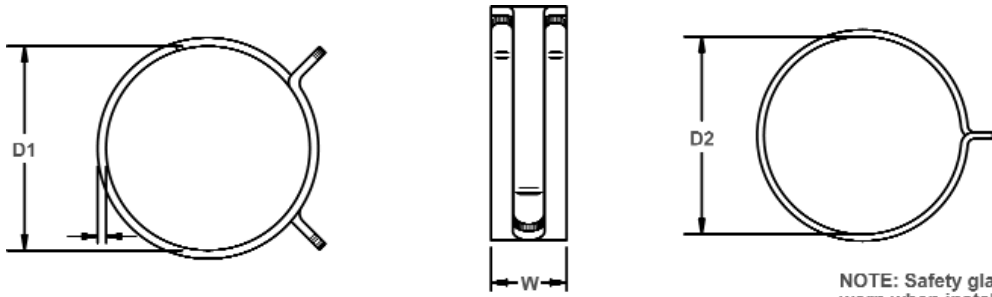

NOTE: Safety glasses should be worn when installing parts.

FINISH: Phosphate; Mechanical Zinc Plate

MATERIAL: SAE 1060-1090 Spring Steel, Austempered

ROTOR CLAMP CTL NO.	NOM. HOSE O.D.		FREE I.D. MAX D1		FULL OPEN DIAMETER MIN D2		W (Ref)		THICKNESS T	
	Inch	mm	Inch	mm	Inch	mm	Inch	mm	Inch	mm
CTL-4	.23	5.9	.210	5.33	.250	6.35	.25	6.3	.020	.51
CTL-4.5	.28	7.1	.240	6.10	.300	7.62	.25	6.3	.015	.38
CTL-4.5 SP1	.28	7.1	.240	6.10	.300	7.62	.25	6.3	.020	.51
CTL-5	.31	7.9	.301	7.65	.345	8.76	.31	7.9	.030	.76
CTL-6	.38	9.5	.321	8.15	.405	10.29	.31	7.9	.020	.51
CTL-6 SP1	.38	9.5	.335	8.51	.410	10.41	.31	7.9	.020	.51
CTL-6.5	.41	10.3	.375	9.53	.450	11.43	.31	7.9	.025	.64
CTL-7	.44	11.1	.405	10.29	.485	12.32	.31	7.9	.025	.64
CTL-7.5	.47	11.9	.430	10.92	.515	13.08	.31	7.9	.025	.64
CTL-8	.50	12.7	.460	11.68	.545	13.84	.31	7.9	.030	.76
CTL-8.5	.53	13.5	.490	12.45	.573	14.55	.31	7.9	.030	.76
CTL-9	.56	14.3	.500	12.70	.621	15.77	.31	7.9	.030	.76
CTL-9 SP1	.56	14.3	.520	13.21	.605	15.37	.31	7.9	.030	.76
CTL-9.5	.59	15.1	.520	13.72	.650	16.51	.31	7.9	.030	.76
CTL-10	.63	15.9	.583	14.81	.668	16.97	.31	7.9	.030	.76
CTL-10.5	.66	16.7	.620	15.75	.725	18.42	.31	7.9	.030	.76
CTL-11	.69	17.5	.583	14.81	.720	18.29	.31	7.9	.030	.76
CTL-11 SP1	.69	17.5	.639	16.23	.709	18.01	.31	7.9	.045	1.14
CTL-11 SP2	.69	17.5	.655	16.64	.750	19.05	.31	7.9	.030	.76
CTL-11.5	.72	18.3	.685	17.40	.775	19.69	.38	9.5	.050	1.27
CTL-12	.75	19.1	.645	16.38	.828	21.03	.38	9.5	.030	.76
CTL-13	.81	20.6	.750	19.05	.900	22.86	.38	9.5	.040	1.02
CTL-14	.88	22.2	.810	20.58	.970	24.64	.38	9.5	.040	1.02
CTL-15	.94	23.8	.860	21.84	1.030	26.16	.38	9.5	.045	1.14
CTL-16	1.00	25.4	.910	23.11	1.080	27.43	.38	9.5	.045	1.14
CTL-16.5	1.03	26.2	.950	24.13	1.130	28.70	.38	9.5	.035	.89
CTL-17	1.06	27.0	.970	24.64	1.180	29.97	.38	9.5	.045	1.14
CTL-18	1.13	28.6	1.040	26.42	1.240	31.50	.38	9.5	.045	1.14
CTL-19	1.19	30.2	1.100	27.94	1.280	32.51	.38	9.5	.045	1.14
CTL-20	1.25	31.8	1.180	29.97	1.450	36.83	.38	9.5	.045	1.14
CTL-24	1.50	38.1	1.350	34.29	1.670	42.42	.38	9.5	.045	1.14
CTL-26	1.63	41.3	1.450	36.83	1.800	45.72	.38	9.5	.045	1.14

Pre-Positioned, Pre-Opened, Self-Compensating Hose Clamp

This band clamp is held in the open position by compressing the tangs and allowing the stop to hook on to a complementary notch on the side on one of the tangs. Must be pre-glued to the hose.

CTO Hose Clamps



Pre-Opened, Pre-Positioned Clamps

This unique, patented version of a preopened clamp is held in the open position by compressing the tangs and allowing the stop to hook on to a complementary notch on the side on one of the tangs.

This clamp is intended solely for rubber hose manufacturers who pre-glue clamps to hoses before supplying to the automotive industry.

A hook catches a "dimple" when the clamp is opened for a more secure hold. The clamp can then be glued in position on a hose.

The mechanism to hold the clamp open is accomplished with only minor changes to the original design of the clamp. The clamp cannot be preopened any further than the stop, ensuring the clamp will not be over-expanded. Contact technical sales for more information:

1-800-557-6867, or e-mail tech@rotorclip.com.



This unique, patented version of a preopened clamp is held in the open position by compressing the tangs and allowing the stop to hook on to a complementary notch on the side of one of the tangs.

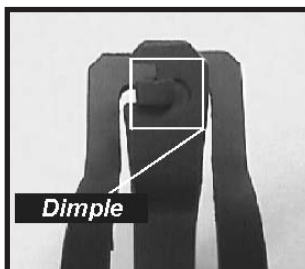

Dimple

The hook catches this "dimple" when the clamp is opened for a more secure hold.

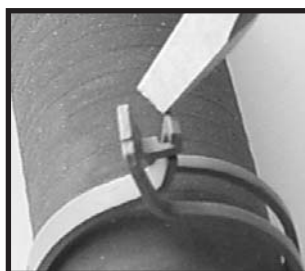

Once the clamp is glued in place on the hose, one can knock the hook off with a screwdriver.



Contact factory for more information regarding options for holding CTOs in the "open" position until ready for installation:
800-557-6867 or +1 732 469-7333

Rotor Clamp personnel are continuously developing and patenting tools to ease installation of clamps to customers: One such innovation is an application system for Pre-Opened hose clamps (CTO).

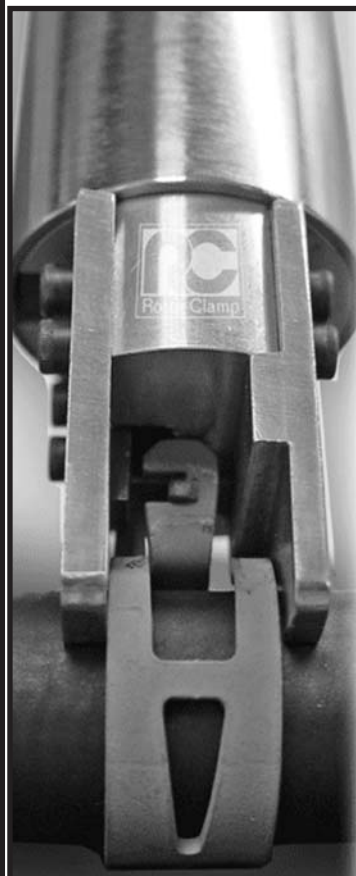

Features and Benefits include:

- Guaranteed placement of the clamp perpendicular to the hose and mating tube.
- Clamp cannot be closed until tool is properly in place.
- Eliminates clamps placed at an angle leading to possible leaks and hose loosening.
- Verification the clamp has been cycled by sending a confirmation to an electronic work station.
- The tool is ergonomic and can fit into limited space requirements due to its unique design.
- Adapts easily to standard assembly line air supply systems.
- Rotor clamp stocks replacement parts and will rebuild or replace tool as necessary.

E-mail sales@rotorclip.com for a demonstration at your site.

Note: CTO clamps are pre-glued to hoses before being supplied to the automotive industry.



Standard Pliers

Standard Retaining Ring Pliers - Inch & Metric

Rotor Clip Standard Retaining Ring Pliers are made of high carbon, heat treated steel and produced to exacting QC specifications. They feature stop and return springs for problem-free installation/removal of retaining rings. This eliminates overspreading of external retaining rings, and speeds the assembly/removal of internal retaining rings by orienting plier to exact location of lug holes. Most Rotor Clip retaining ring pliers have exclusive air-cushioned handles.



Inch Plier Dimensions

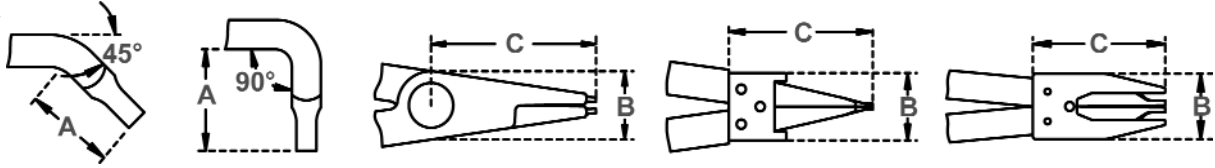

Internal Inch

For use with the following inch retaining rings:

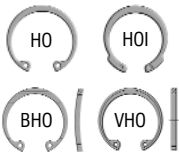

INTERNAL STANDARD PLIERS								GENERAL DIMENSIONS (inches)						
Ring Series/Size Range				ROTOR CLIP PLIERS	45° TIP PLIERS	90° TIP PLIERS	Weight lbs.	Tip Dia.	Tip Length A	CLOSED POSITION				
HO-BHO-VHO		HOI								Clearance		Length Std. Tip	Width	
FROM	THRU	FROM	THRU	B	C									
-25	-31	-62	-	RPS-100	RPS-104	RPS-109	.15	.025	9/32	7/8	1-7/8	5-1/2	1-7/8	
-37	-56	-75	-100	RP-100	RP-104	RP-109	.15	.038	9/32	7/8	1-7/8	5-1/2	1-7/8	
-62	-102	-106	-137	RPL-100	RPL-104	RPL-109	.15	.047	9/32	7/8	1-7/8	5-1/2	1-7/8	
-106	-175	-143	-200	RP-300	RP-304	RP-309	.17	.070	11/32	7/8	2-1/8	6-7/16	2-1/4	
-181	-300	-206	-300	RP-500	RP-504	RP-509	.62	.090	7/16	1-1/8	2-3/4	9	2-1/4	

External Inch

For use with the following inch retaining rings:

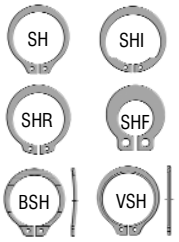

EXTERNAL STANDARD PLIERS										GENERAL DIMENSIONS (inches)							
Ring Series/Size Range								ROTOR CLIP PLIERS	45° TIP PLIERS	90° TIP PLIERS	Weight lbs.	Tip Dia.	Tip Length A	CLOSED POSITION			
SH-BSH-VSH		SHI		SHR		SHF								Clearance		Length Std. Tip	Width
FROM	THRU	FROM	THRU	FROM	THRU	FROM	THRU	B	C								
-12	-	-	-	-	-	-	-	RP-12	RP-2124	RP-2129	.05	.023	7/32	1/2	1-1/8	5-5/16	1-1/2
-15	-	-	-	-	-	-	-	RP-15	RP-2154	RP-2159	.05	.023	7/32	1/2	1-1/8	5-5/17	1-1/2
-18	-23	-	-	-	-	-	-	RP-18	RP-2184	RP-2189	.05	.023	7/32	1/2	1-1/8	5-5/18	1-1/2
-25	-66	-50	-78	-39	-47	-	-	RP-200	RP-204	RP-209	.15	.038	9/32	1	2	5-1/2	2-1/2
-68	-87	-81	-100	-50	-66	-	-	RPL-200	RPL-204	RPL-209	.15	.047	9/32	1	2	5-1/2	2-1/2
-93	-143	-106	-200	-	-	-	-	RP-400	RP-404	RP-409	.19	.070	11/32	1	2-3/8	7	2-7/8
-150	-350	-215	-334	-	-	-	-	RP-600	RP-604	RP-609	.44	.115	7/16	1-1/4	3-1/16	9-1/8	4-1/4
-	-	-	-	-75	-98	-31	-75	RPA-2	RPA-245	RPA-290	.22	.070	9/16	1	2	7-1/4	2-1/2

External pliers RP-12, RP-15 & RP-18 are available in the standard version with shielded tips. The 45° and 90° versions are unshielded. Both are equipped with fixed stops to prevent overspreading of the external retaining rings during installation or removal.

Metric Plier Dimensions

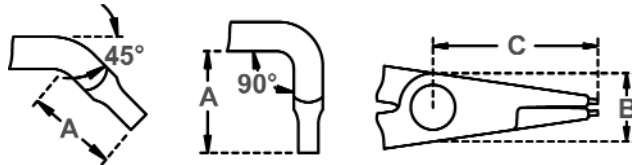

Please wear protective eyewear while installing and removing retaining rings & hose clamps.

Internal Metric

For use with the following metric retaining rings:



METRIC INTERNAL PLIERS (All Dimensions in mm)						FULLY COMPRESSED (TIPS BUTTING) CONDITION					
Ring Series/Size Range		ROTOR CLIP PLIERS	45° TIP PLIERS	90° TIP PLIERS	Weight Kg	Tip Dia.	Tip Length A	Tip Clearance		Overall Length Straight Tip	Max Width Across Handle
DHO (DIN 472), DHT (DIN 984)								B	C		
FROM	THRU										
-8	-9	RPI-0	RPI-045	RPI-090	0.07	0.9	8	19	48	140	45
-10	-17	RPI-1	RPI-145	RPI-190	0.07	1.3	8	19	48	140	45
-18	-30	RPI-2	RPI-245	RPI-290	0.1	1.8	10	25	55	165	60
-31	-83	RPI-3	RPI-345	RPI-390	0.23	2.3	14	30	70	230	65
-85	-100	RPI-4	RPI-445	RPI-490	0.42	3.2	20	45	70	300	55

External Metric

For use with the following metric retaining rings:



METRIC EXTERNAL PLIERS (All Dimensions in mm)						FREE (UNEXPANDED) CONDITION					
Ring Series/Size Range		ROTOR CLIP PLIERS	45° TIP PLIERS	90° TIP PLIERS	Weight Kg	Tip Dia.	Tip Length A	Tip Clearance		Overall Length Straight Tip	Max Width Across Handle
DSH (DIN 471), DST (DIN 983)								B	C		
FROM	THRU										
-3	-9	RPA-0	RPA-045	RPA-090	0.07	0.9	8	22	38	140	75
-10	-17	RPA-1	RPA-145	RPA-190	0.07	1.3	8	22	38	140	75
-18	-30	RPA-2	RPA-245	RPA-290	0.1	1.8	14	25	50	185	100
-31	-82	RPA-3	RPA-345	RPA-390	0.23	2.3	14	30	75	230	105
-85	-100	RPA-4	RPA-445	RPA-490	0.46	3.2	20	45	80	300	175

Ratchet & Grip Ring Pliers



Ratchet Retaining Ring Pliers

Assemble large retaining rings up to 10" in diameter with ease and comfort using Rotor Clip Ratchet Pliers. Spring loaded mechanisms compress or expand large rings through gradual "steps." Plier locks at the desired size without continued pressure on the handles.

(Note: Ratchet Pliers do not include plier tips, which must be purchased separately.)

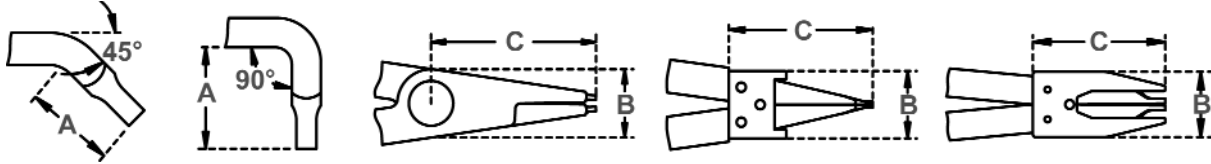

RATCHET PLIERS INTERNAL**										GENERAL DIMENSIONS (inches)						
Ring Series/Size Range				PLIERS W/OUT TIPS	STD. TIPS	45° TIPS	90° TIPS	TIP COLOR CODE	Weight lbs.	Tip Dia.	Tip Length A	CLOSED POSITION				
HO-BHO-VHO	HOI											Clearance	Length Std. Tip	Width		
FROM	THRU	FROM	THRU								B	C				
-181	-237	-206	-250	RP-27R	RP-5021R	RP-5023R	RP-5024R	GOLD	.70	.093	15/32	1-3/8	3-13/32	10-5/8	3	
-244	-300	-262	-300	RP-27R	RP-5005R	RP-5007R	RP-5008R	BLACK	.70	.108	15/32	1-3/8	3-13/32	10-5/8	3	
-306	-400	-315	-400	RP-27R	RP-5009R	RP-5012R	RP-5013R	SILVER	.70	.120	15/32	1-3/8	3-13/32	10-5/8	3	
-306	-600	-315	-400	RP-900	RP-7801R	RP-7845R	RP-7890R	BLACK	1.9	.120	1/2	1-3/4	3-1/2	16	3-7/8	
-625	-1000	-	-	RP-1100	RP-71001R	RP-71451R	RP-71901R	BLACK	5.0	.150	1-5/32	1-3/4	4-5/16	28	6-1/2	

**PLIERS AND PLIER TIPS MUST BE ORDERED TOGETHER TO BE USABLE. TIPS ARE INTERCHANGEABLE FOR INTERNAL AND EXTERNAL USE.

Internal
For use with the following retaining rings:

RATCHET PLIERS EXTERNAL**										GENERAL DIMENSIONS (inches)							
Ring Series/Size Range						PLIERS W/OUT TIPS	STD. TIPS	45° TIPS	90° TIPS	TIP COLOR CODE	Weight lbs.	Tip Dia.	Tip Length A	CLOSED POSITION			
SH-BSH-VSH	SHI		SHR											Clearance	Length Std. Tip	Width	
FROM	THRU	FROM	THRU	FROM	THRU								B	C			
-	-	-	-	-106	-137	RP-28R	RP-5021R	RP-5023R	RP-5024R	GOLD	.70	.093	15/32	1-3/8	3-3/8	10-5/8	4-11/32
-150	-375	-215	-325	-	-	RP-28R	RP-5009R	RP-5012R	RP-5013R	SILVER	.70	.120	15/32	1-3/8	3-3/8	10-5/8	4-11/32
-	-	-	-	-150	-175	RP-1000	RP-8002R	RP-8452R	RP-8902R	BLACK	1.9	.108	5/8	2-1/2	3-5/8	14-1/2	13
-354	-650	-350	-393	-193	-200	RP-1000	RP-7801R	RP-7845R	RP-7890R	BLACK	1.9	.120	5/8	2-1/2	3-5/8	14-1/2	13
-675	-950	-	-	-	-	RP-1200	RP-68001R	RP-68451R	RP-68901R	BLACK	2.2	.170	1-5/32	2-1/2	4-7/8	18-1/4	14

**PLIERS AND PLIER TIPS MUST BE ORDERED TOGETHER TO BE USABLE. TIPS ARE INTERCHANGEABLE FOR INTERNAL AND EXTERNAL USE.

External
For use with the following retaining rings:



Grip Ring Retaining Ring Pliers

Rotor Clip Grip Ring Pliers are designed for SHF & DSF external (shaft) friction rings. The pliers are made of forged Chrome Vanadium steel with non-slip solid tips, and the handles have a non-slip plastic coating.

Please wear protective eyewear while installing and removing retaining rings & hose clamps.

HEAVY DUTY PLIERS - EXTERNAL (Inch & Metric)				
Ring Series/Size Range				ROTOR CLIP PLIERS
SHF (in.)		DSF (mm)		
FROM	THRU	FROM	THRU	
-6	-9	-1.5	-4	RPN-G0
-12	-15	-4	-7	RPN-G1
-18	-25	-5	-13	RPN-G2
-31	-75	-14	-18	RPN-G3

External
For use with the following retaining rings:



Convertible & Heavy-Duty Pliers

Convertible Retaining Ring Pliers

Convert quickly and easily from internal to external pliers and back again. This two-in-one capability is cost effective and ideal for handling a variety of applications with a minimum number of tools. Simply move the screw to the other hole and tighten with finger pressure to convert quickly to an internal/external plier.

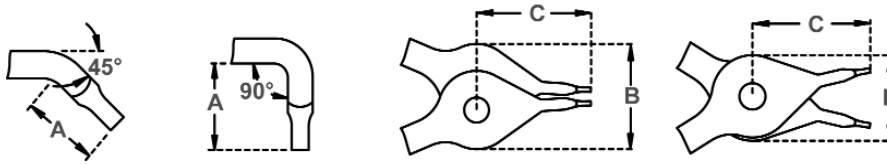

Please wear protective eyewear while installing and removing retaining rings & hose clamps.

Internal

For use with the following retaining rings:

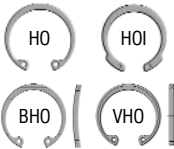

CONVERTIBLE PLIERS, INTERNAL RING SERIES									GENERAL DIMENSIONS (inches)					
Ring Series/Size Range				ROTOR CLIP PLIERS	45° TIP PLIERS	90° TIP PLIERS	Weight lbs.	Tip Dia.	Tip Length A	CLOSED POSITION				
HO-BHO-VHO		HOI								Clearance		Length Std. Tip		Width
FROM	THRU	FROM	THRU						B	C				
-37	-43	-75	-100	RP-120	RP-124	RP-129	.19	.038	9/32	1-3/16	1-5/8	5-5/8	1-3/4	
-45	-102	-106	-137	RP-320	RP-324	RP-329	.19	.047	9/32	1-3/16	1-5/8	5-5/8	1-3/4	
-106	-175	-143	-200	RP-340	RP-344	RP-349	.45	.070	11/32	1-7/16	1-7/8	7-7/8	3-5/16	
-181	-206	-206	-212	RP-560	RP-564	RP-569	.55	.090	5/8	1-3/4	3	9-1/4	4-1/2	

External

For use with the following retaining rings:

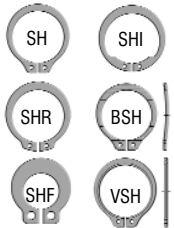

CONVERTIBLE PLIERS, EXTERNAL RING SERIES									GENERAL DIMENSIONS (inches)								
Ring Series/Size Range				ROTOR CLIP PLIERS	45° TIP PLIERS	90° TIP PLIERS	Weight lbs.	Tip Dia.	Tip Length A	CLOSED POSITION							
SH-BSH-VSH		SHI								SHR		SHF		Clearance		Length	
FROM	THRU	FROM	THRU	FROM	THRU	FROM	THRU				B	C					
-25	-60	-50	-78	-39	-47	-12	-25	RP-120	RP-124	RP-129	.19	.038	9/32	1-3/8	1-5/8	5-5/8	2-9/16
-68	-87	-81	-100	-50	-66	-31	-37	RP-320	RP-324	RP-329	.19	.047	9/32	1-3/8	1-5/8	5-5/8	2-9/16
-93	-143	-106	-200	-75	-98	-43	-75	RP-340	RP-344	RP-349	.45	.070	11/32	1-11/16	1-7/8	7-7/8	3-15/16
-150	-200	-	-	-	-	-	-	RP-560	RP-564	RP-569	.55	.090	5/8	1-7/8	3	9-1/4	4-1/2

Heavy-Duty Retaining Ring Pliers

Rotor Clip Heavy-Duty Retaining Ring Pliers are designed to perform with excessive use - up to 10 times longer than standard retaining ring pliers. The pliers are made of forged Chrome Vanadium steel, and the handles have a non-slip plastic coating. They feature inserted tips of high density drawn spring wire and a precise, smooth operating screw joint. Large contact faces on the tips helps to eliminate distortion of the ring, and the slim head style allows for use in confined areas.



Internal

For use with the following retaining rings:

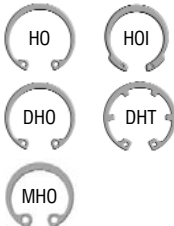

HEAVY DUTY PLIERS - INTERNAL (Inch & Metric)											ROTOR CLIP PLIERS	90° CLIP PLIERS	TIP DIAMETER
Ring Series/Size Range													
HO		HOI		DHO (DIN 472)		DHT (DIN 984)		MHO (ANSI Metric)					
(in.)		(in.)		(mm)		(mm)		(mm)					
FROM	THRU	FROM	THRU	FROM	THRU	FROM	THRU	FROM	THRU				
-37	-56	-75	-100	-8	-13	-	-	-8	-15	RPN-J0	RPN-J01	0.9	
-62	-102	-106	-137	-12	-25	-16	-25	-15	-26	RPN-J1	RPN-J11	1.2	
-106	-175	-143	-200	-19	-60	-19	-60	-27	-60	RPN-J2	RPN-J21	1.8	
-181	-300	-206	-300	-40	-100	-40	-100	-62	-100	RPN-J3	RPN-J31	2.3	

External

For use with the following retaining rings:

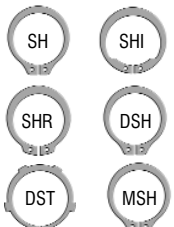

HEAVY DUTY PLIERS - EXTERNAL (Inch & Metric)											ROTOR CLIP PLIERS	90° CLIP PLIERS	TIP DIAMETER
Ring Series/Size Range													
SH		SHI		SHR		DSH (DIN 471) DST (DIN 983)		MSH (ANSI Metric)					
(in.)		(in.)		(in.)		(mm)		(mm)					
FROM	THRU	FROM	THRU	FROM	THRU	FROM	THRU	FROM	THRU				
-25	-66	-50	-78	-39	-47	-3	-10	-4	-12	RPN-A0	RPN-A01	0.9	
-68	-87	-81	-100	-50	-66	-10	-25	-13	-23	RPN-A1	RPN-A11	1.2	
-93	-143	-106	-220	-75	-98	-19	-60	-24	-36	RPN-A2	RPN-A21	1.8	
-150	-350	-215	-350	-	-	-40	-100	-38	-90	RPN-A3	RPN-A31	2.3	

Dispensers

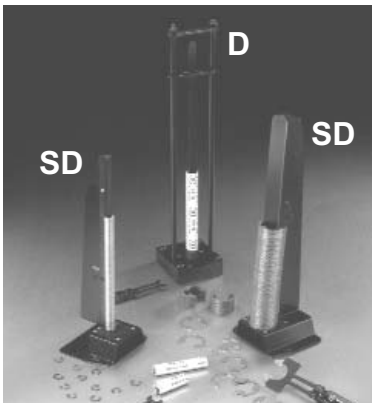

Retaining Ring Dispensers Rotor Clip retaining ring dispensers feature “rail” over which a stack of retaining rings can be slipped. Once in position, they can be “dispensed” one at a time using a retaining ring applicator for ease of installation. Two such models are available to meet your particular dispensing needs: **Spring Rail (SD)** dispensers are competitively priced and offer significant improvements (like more rail capacity and durable construction) on existing designs. For use with Rotor Clip **C, E/SE/YE, RE, PO/POL, DE, DC, ME & JE** rings. **The Heavy Duty (D)** is a more permanent version which features replaceable parts and can be permanently affixed to your work station.

Features:

- Sturdy, Industrial-Quality Construction.
- Fast, Easy Loading.
- Accept Tape-Stacked Rings.
- Precise, Single Ring Ejection.
- Longer Rail For More Capacity.
- Part and Tool Number Stamped on Dispenser for Fast, Easy Identification of Tool and Corresponding Ring.
- Powder Metal Coating for a Durable, No-Rust Finish (Spring Rail Dispenser, Only.)

C Dispensers
For use with Rotor Clip “C” Rings.

HEAVY-DUTY DISP.		SPRING-RAIL DISP.	
RING SIZE	DISP. NO.	RING SIZE	DISP. NO.
C-12	D-10	C-12	SD-10
C-15	D-20	C-15	SD-20
C-18	D-30	C-18	SD-30
C-21	D-40	C-21	SD-40
C-23	D-50	C-23	SD-50
C-25	D-60	C-25	SD-60
C-28	D-70	C-28	SD-70
C-31	D-80	C-31	SD-80
C-37	D-90	C-37	SD-90
C-40	D-100	C-40	SD-100
C-43	D-110	C-43	SD-110
C-50	D-120	C-50	SD-120
C-56	D-130	C-56	SD-130
C-62	D-140	C-62	SD-140
C-68	D-150	C-68	SD-150
C-75	D-160	C-75	SD-160
C-81	D-170	C-81	SD-170
C-87	D-180	C-87	SD-180
C-100	D-190	C-100	SD-190
C-112	D-200	C-112	SD-200

E Dispensers
For use with Rotor Clip “E/SE/YE” Rings.

HEAVY-DUTY DISP.		SPRING-RAIL DISP.	
RING SIZE	DISP. NO.	RING SIZE	DISP. NO.
SE-6	D-390	SE-6	SD-390
YE-6	D-460	YE-6	SD-460
E-6	D-210	E-6	SD-210
SE-9	D-330	SE-9	SD-395
E-9	D-220	E-9	SD-220
SE-11	D-400	SE-11	SD-400
SE-12	D-231	SE-14	SD-405
SE-14	D-230	E-12	SD-230
E-12	D-230	YE-14	SD-465
YE-14	D-465	E-14	SD-240
E-14	D-240	E-15	SD-250
E-15	D-250	SE-17	SD-410
SE-17	D-410	SE-18	SD-415
SE-18	D-350	E-18	SD-260
E-18	D-260	SE-21	SD-416
SE-21	D-360	E-25	SD-270
E-25	D-270	SE-31	SD-420
SE-31	D-420	SE-43	SD-430
SE-37	D-608	E-37	SD-280
E-37	D-280	E-43	SD-290
E-43	D-290	SE-74	SD-440
SE-43	D-430	E-50	SD-300
E-50	D-300	E-62	SD-305
E-62	D-160	SE-98	SD-450
SE-74	D-440	E-75	SD-310
E-75	D-310	E-87	SD-320
E-87	D-320		
SE-98	D-450		

PO POL Dispensers
For use with Rotor Clip “PO/POL” Rings.

HEAVY-DUTY DISP.		SPRING-RAIL DISP.	
RING SIZE	DISP. NO.	RING SIZE	DISP. NO.
PO-15	D-800	PO-15	SD-800
PO-18	D-810	PO-18	SD-810
PO-25	D-820	PO-25	SD-820
PO-31	D-830	PO-31	SD-830
PO-37	D-840	PO-37	SD-840
PO-43	D-850	PO-43	SD-850
PO-50	D-860	PO-50	SD-860
POL-15	D-900	POL-15	SD-900
POL-18	D-910	POL-18	SD-910
POL-25	D-820	POL-25	SD-920
POL-31	D-930	POL-31	SD-930
POL-37	D-840	POL-37	SD-940
POL-43	D-950	POL-43	SD-950
POL-50	D-960	POL-50	SD-960

JE Dispensers
For use with Rotor Clip “JE” Rings.

HEAVY-DUTY DISP.		HEAVY-DUTY DISP.	
RING SIZE	DISP. NO.	RING SIZE	DISP. NO.
JE-2.5	D-330	JE-6	D-759
JE-3	D-240	JE-8	D-761
JE-4	D-757	JE-12	D-730
JE-5	D-758		

RE Dispensers
For use with Rotor Clip “RE” Rings.

HEAVY-DUTY DISP.		SPRING-RAIL DISP.	
RING SIZE	DISP. NO.	RING SIZE	DISP. NO.
RE-9	D-330	RE-9	SD-330
RE-12	D-340	RE-12	SD-340
RE-15	D-350	RE-15	SD-350
RE-18	D-260	RE-18	SD-355
RE-21	D-360	RE-21	SD-360
RE-25	D-270	RE-25	SD-365
RE-31	D-370	RE-31	SD-370
RE-37	D-280	RE-37	SD-375
RE-43	D-380	RE-43	SD-380
RE-50	D-300	RE-50	SD-385
RE-56	D-150	RE-56	SD-386

ME Dispensers
For use with Rotor Clip “ME” Rings.

HEAVY-DUTY DISP.		HEAVY-DUTY DISP.	
RING SIZE	DISP. NO.	RING SIZE	DISP. NO.
ME-2	D-210	ME-10	D-280
ME-3	D-230	ME-11	D-290
ME-4	D-250	ME-12	D-660
ME-5	D-260	ME-13	D-300
ME-6	D-360	ME-15	D-672
ME-7	D-270	ME-16	D-160
ME-8	D-370	ME-22	D-320
ME-9	D-690		

DE Dispensers
For use with Rotor Clip “DE” Rings.

HEAVY-DUTY DISP.		SPRING-RAIL DISP.	
RING SIZE	DISP. NO.	RING SIZE	DISP. NO.
DE-1,2	D-712	DE-1,5	SD-715
DE-1,5	D-715	DE-1,9	SD-719
DE-1,9	D-719	DE-2,3	SD-723
DE-2,3	D-723	DE-3,2	SD-732
DE-3,2	D-732	DE-4	SD-704
DE-4	D-410	DE-5	SD-705
DE-5	D-360	DE-6	SD-706
DE-6	D-360	DE-7	SD-707
DE-7	D-607	DE-8	SD-708
DE-8	D-608	DE-9	SD-709
DE-9	D-610	DE-10	SD-610
DE-10	D-610	DE-12	SD-612
DE-12	D-612		

Please wear protective eyewear while installing and removing retaining rings & hose clamps.



Applicators

Retaining Ring Applicators

Applicators are designed to install standard inch & metric radial retaining rings on a shaft. Used with Rotor Clip Dispensers, applicators enable operators to install rings quickly and correctly and allows for installation without turning the tool (ring “snaps” when properly seated in groove.) Heat treated for strength. For use with Rotor Clip C, E, BE, RE, PO/POL, EL, DE, DC, ME and JE Retaining rings.

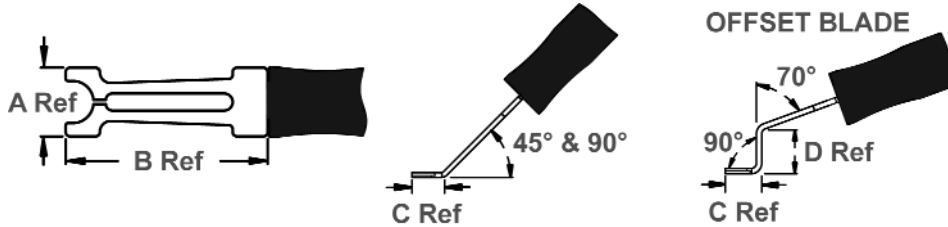

E Applicator For use with Rotor Clip “E/SE/YE” Rings.*

RING SIZE	APP. NO.	BLADE WIDTH A	BLADE LENGTH B	TIP LENGTH C	OFFSET D
E-4	A-010	.265	1.438	.375	.250
SE-6	A-020	.265	1.438	.375	.375
YE-6	A-030	.500	1.438	.375	.375
E-6	A-040	.265	1.438	.375	.375
SE-9	A-050	.500	1.438	.375	.375
E-9	A-510	.500	1.438	.375	.375
SE-11	A-060	.500	1.438	.375	.375
E-12	A-050	.500	1.438	.375	.375
SE-14	A-080	.500	1.438	.375	.375
YE-14	A-090	.500	1.438	.375	.375
E-14	A-070	.500	1.438	.375	.375
E-15	A-100	.500	1.438	.375	.375
SE-17	A-110	.500	1.438	.375	.375
SE-18	A-130	.500	1.438	.375	.375
E-18	A-120	.500	1.438	.375	.375
SE-21	A-140	.812	2.218	.593	.625
E-25	A-150	.812	2.218	.593	.625
SE-31	A-160	.812	2.218	.593	.625
SE-37	A-290	.812	2.218	.593	.625
E-37	A-170	.812	2.218	.593	.625
E-43	A-180	.812	2.218	.593	.625
SE-43	A-190	.812	2.218	.593	.625
E-50	A-200	1.125	2.390	.765	.625
E-62	A-210	1.125	2.390	.765	.625
SE-74	A-220	1.562	2.625	.969	.625
E-75	A-230	1.562	2.625	.969	.625
E-87	A-240	1.562	2.625	.969	.625
SE-98	A-250	1.875	2.844	1.188	.625
SE-118	A-260	1.875	2.844	1.188	.625

RE Applicator For use with Rotor Clip “RE” Rings.*

RING SIZE	APP. NO.	BLADE WIDTH A	BLADE LENGTH B	TIP LENGTH C	OFFSET D
RE-9	A-080	.500	1.438	.375	.375
RE-12	A-520	.500	1.438	.375	.375
RE-15	A-120	.500	1.438	.375	.375
RE-18	A-130	.500	1.438	.375	.375
RE-21	A-140	.812	2.218	.593	.625
RE-25	A-160	.812	2.218	.593	.625
RE-31	A-500	.812	2.218	.593	.625
RE-37	A-170	.812	2.218	.593	.625
RE-43	A-270	1.125	2.390	.765	.625
RE-50	A-200	1.125	2.390	.765	.625
RE-56	A-280	1.125	2.390	.765	.625

C Applicator For use with Rotor Clip “C” Rings.*

RING SIZE	APP. NO.	BLADE WIDTH A	BLADE LENGTH B	TIP LENGTH C	OFFSET D
C-12	A-300	.264	1.438	.375	.375
C-15	A-080	.500	1.438	.375	.375
C-18	A-090	.500	1.438	.375	.375
C-21	A-310	.500	1.438	.375	.375
C-23	A-320	.500	1.438	.375	.375
C-25	A-330	.500	1.438	.375	.375
C-28	A-340	.500	1.438	.375	.375
C-31	A-350	.500	1.438	.375	.375
C-37	A-360	.812	2.218	.593	.625
C-40	A-370	.812	2.218	.593	.625
C-43	A-380	.812	2.218	.593	.625
C-50	A-290	.812	2.218	.593	.625
C-56	A-390	.812	2.218	.593	.625
C-62	A-400	1.125	2.390	.765	.625
C-68	A-410	1.125	2.390	.765	.625
C-75	A-280	1.125	2.390	.765	.625
C-81	A-420	1.125	2.390	.765	.625
C-87	A-430	1.125	2.390	.765	.625
C-93	A-440	1.562	2.625	.969	.625
C-100	A-450	1.562	2.625	.969	.625
C-112	A-460	1.562	2.625	.969	.625
C-125	A-470	1.562	2.625	.969	.625
C-137	A-480	1.562	1.875	1.188	.625
C-150	A-490	1.562	1.875	1.188	.625
C-162	A-491	2.250	3.344	N/A	N/A
C-175	A-492	2.250	3.344	N/A	N/A

PO POL Applicator For use with Rotor Clip “PO/POL” Rings.**

RING SIZE	APP. NO.	BLADE WIDTH A	BLADE LENGTH B	TIP LENGTH C	OFFSET D
PO-15	A-815	.500	1.438	.375	.625
PO-18	A-818	.812	2.218	.593	.625
PO-25	A-825	.812	2.218	.593	.625
PO-31	A-831	.812	2.218	.593	.625
PO-37	A-837	1.125	2.390	.765	.625
PO-43	A-843	1.125	2.390	.765	.625
PO-50	A-850	1.125	2.390	.765	.625
POL-15	A-915	.500	1.438	.375	.625
POL-18	A-918	.812	2.218	.593	.625
POL-25	A-925	.812	2.218	.593	.625
POL-31	A-931	.812	2.218	.593	.625
POL-37	A-937	1.125	2.390	.765	.625
POL-43	A-943	1.125	2.390	.765	.625
POL-50	A-950	1.125	2.390	.765	.625

JE Applicator For use with Rotor Clip “JE” Rings.**

RING SIZE	APP. NO.	BLADE WIDTH A	BLADE LENGTH B	TIP LENGTH C	OFFSET D
JE-2	A-080	.500	1.438	.375	.375
JE-2.5	A-050	.500	1.438	.375	.375
JE-3	A-070	.500	1.438	.375	.375
JE-4	A-340	.500	1.438	.375	.375
JE-5	A-605	.812	2.218	.593	.625
JE-6	A-606	.812	2.218	.593	.625
JE-7	A-607	.812	2.218	.593	.625
JE-8	A-608	.812	2.218	.593	.625
JE-12	A-612	1.562	2.625	.969	.625

Please wear protective eyewear while installing and removing retaining rings & hose clamps.

*45°, 90° and Offset applicators for C, E and RE retaining rings - Replace the last “0” of the applicator designation with a “4” (45°), “9” (90°), or “7” (Offset.) (Ex., A-304, A-309, A-307, etc.)

**45°, 90° and Offset applicators for DE, DC, PO/POL, EL, JE and ME retaining rings - To the end of the applicator designation, add a “4” (45°), “9” (90°), or “7” (Offset.) (Ex., A-7084, A-7089, A-7087, etc.)



Applicators



Applicator

For use with Rotor Clip "DE" Rings.**

RING SIZE	APP. NO.	BLADE WIDTH A	BLADE LENGTH B	TIP LENGTH C	OFFSET D
DE-0.8	A-708	.265	1.438	.375	.375
DE-1.2	A-712	.265	1.438	.375	.375
DE-1.5	A-715	.265	1.438	.375	.375
DE-1.9	A-719	.265	1.438	.375	.375
DE-2.3	A-723	.500	1.438	.375	.375
DE-3.2	A-310	.500	1.438	.375	.375
DE-4	A-340	.500	1.438	.375	.375
DE-5	A-605	.812	2.218	.593	.625
DE-6	A-606	.812	2.218	.593	.625
DE-7	A-607	.812	2.218	.593	.625
DE-8	A-608	.812	2.218	.593	.625
DE-9	A-609	1.125	2.390	.765	.625
DE-10	A-610	1.125	2.390	.765	.625
DE-12	A-612	1.562	2.625	.969	.625
DE-15	A-615	1.562	2.625	.969	.625
DE-19	A-619	1.875	2.844	1.188	.625



Applicator

For use with Rotor Clip "ME" Rings.**

RING SIZE	APP. NO.	BLADE WIDTH A	BLADE LENGTH B	TIP LENGTH C	OFFSET D
ME-1	A-010	.265	1.438	.375	.375
ME-2	A-040	.265	1.438	.375	.375
ME-3	A-050	.500	1.438	.375	.375
ME-4	A-100	.500	1.438	.375	.375
ME-5	A-120	.500	1.438	.375	.375
ME-6	A-140	.812	2.218	.593	.625
ME-7	A-150	.812	2.218	.593	.625
ME-8	A-290	.812	2.218	.593	.625
ME-9	A-608	.812	2.218	.593	.625
ME-10	A-170	.812	2.218	.593	.625
ME-11	A-180	.812	2.218	.593	.625
ME-12	A-609	1.125	2.390	.765	.625
ME-13	A-200	1.125	2.390	.765	.625
ME-15	A-612	1.125	2.390	.969	.625
ME-16	A-210	1.125	2.390	.765	.625
ME-22	A-240	1.125	2.625	.969	.625

For Bowed "E" Rings



Applicator

For use with Rotor Clip "BE/BSE" Rings.

RING SIZE	APP. NO.	BLADE WIDTH A	BLADE LENGTH B	TIP LENGTH C	OFFSET D
BSE-11	A-550	.500	1.375	.375	.375
BE-12	A-551	.500	1.375	.375	.375
BE-14	A-552	.500	1.375	.375	.375
BSE-14	A-553	.500	1.375	.375	.375
BE-15	A-554	.500	1.375	.375	.375
BSE-17	A-555	.500	1.375	.375	.375
BE-18	A-556	.500	1.375	.375	.375
BSE-18	A-557	.500	1.375	.375	.375
BSE-21	A-558	.812	2.156	.625	.625
BE-25	A-559	.812	2.156	.625	.625
BSE-31	A-560	.812	2.156	.625	.625
BE-37	A-561	.812	2.156	.625	.625
BE-43	A-562	.812	2.156	.625	.625
BSE-43	A-563	.812	2.156	.625	.625
BE-50	A-564	1.125	2.250	.750	.875
BE-62	A-565	1.125	2.250	.750	1.000
BSE-74	A-566	1.562	2.469	1.093	1.000
BE-75	A-567	1.562	2.469	1.093	1.000
BE-87	A-568	1.562	2.469	1.093	1.000
BSE-98	A-569	1.875	2.812	1.188	1.188

*45°, 90° and Offset applicators for C, E and RE retaining rings - Replace the last "0" of the applicator designation with a "4" (45°), "9" (90°), or "7" (Offset.) (Ex., A-304, A-309, A-307, etc.)

**45°, 90° and Offset applicators for DE, DC, PO/POL, EL, JE and ME retaining rings - To the end of the applicator designation, add a "4" (45°), "9" (90°), or "7" (Offset.) (Ex., A-7084, A-7089, A-7087, etc.)

Please wear protective eyewear while installing and removing retaining rings & hose clamps.



Applicator

For use with Rotor Clip "DC" Rings.**

RING SIZE	APP. NO.	RING SIZE	APP. NO.	RING SIZE	APP. NO.	RING SIZE	APP. NO.
DC-3	A-545	DC-12	A-290	DC-22	A-583	DC-36	A-592
DC-4	A-080	DC-13	A-190	DC-23	A-584	DC-38	A-593
DC-5	A-723	DC-14	A-390	DC-24	A-585	DC-40	A-594
DC-6	A-320	DC-15	A-577	DC-25	A-586	DC-42	A-595
DC-7	A-120	DC-16	A-400	DC-26	A-587	DC-45	A-596
DC-8	A-570	DC-17	A-579	DC-28	A-588	DC-48	A-597
DC-9	A-571	DC-18	A-200	DC-30	A-589	DC-50	A-598
DC-10	A-572	DC-19	A-280	DC-32	A-590	DC-52	A-599
DC-11	A-573	DC-20	A-582	DC-35	A-591	DC-55	A-600

Please contact Technical Sales for DC applicator specifications: 800.557.6867, +1 732.469.7333, tech@rotorclip.com.

For "EL" Retaining Rings with Grip (D)



Applicator

For use with Rotor Clip "EL" Rings.**

RING SIZE	APP. NO.	BLADE WIDTH A	BLADE LENGTH B	TIP LENGTH C	*** REPLC. GRIPS
EL-9	A-091	.438	2.188	.375	A-091G
EL-12	A-112	.438	2.188	.375	A-112G
EL-18	A-118	.625	2.188	.563	A-118G
EL-25	A-125	.750	2.188	.625	A-125G
EL-31	A-131	1.000	2.625	.750	A-131G
EL-37	A-371	1.125	2.625	.813	A-371G
EL-43	A-143	1.125	2.625	.938	A-143G

*** An EL applicator consists of a tool and a grip. Replacement grips may be purchased without replacing the tool by using these order numbers.



Heavy Duty Applicator Handles



Install large PO/POL retaining rings (sizes -60 to -100) quickly and safely. Features an applicator blade affixed to

a heavy-duty handle. Plastic grip enables you to hold tool steady as you strike the rear of the tool with a hammer/mallet to install the ring. Shield at top prevents injury.

RING SIZE	APP. NO.	BLADE WIDTH
PO-62	A-862	1.125
PO-75	A-875	1.562
PO-100	A-810	1.875
POL-62	A-962	1.125
POL-75	A-975	1.562
POL-100	A-910	1.875



TX Applicator - "Easy Guide"

Designed to comfortably fit in the palm of your hand, the lightweight TX Easy Guide allows you to painlessly install Rotor Clip's TX self-locking retaining rings. The nose is constructed from tool steel, a life extending material. Inside is a spring-loaded magnet. This magnet aggressively holds a retaining ring in place during installation. The spring, along with the magnet, retracts into the handle while the tool forces the retaining ring over the shaft. Each ring is assigned its own Easy Guide, producing maximum tool performance.

RING SIZE	EASY-GUIDE TX TOOL #	FOR SHAFT DIA.
TX-9	RP-21104	3/32"
TX-12	RP-21105	1/8"
TX-15	RP-21106	5/32"
TX-18	RP-21107	3/16"
TX-25	RP-21108	1/4"
TX-31	RP-21109	5/16"
TX-37	RP-21110	3/8"
TX-43	RP-21111	7/16"
TX-50	RP-21112	1/2"

External

For use with the following retaining ring:



Automatic Assembly Tools

Pneumatic Retaining Ring Tools

These pneumatic hand tools automate assembly using a compressed air line (85 psi). Saves time while eliminating injury. Pneumatic Retaining Ring Tools are designed to fit the following inch/metric retaining rings: **HO, VHO, BHO, HOI, SH, VSH, BSH, SHI, SHR, DHO, DSH, DST, DHT.**

Call **1-800-557-6867** for technical information, or e-mail tech@rotorclip.com.

* Note: Power pack and tips must be purchased together for tool to operate.



External For use with the following retaining rings:



EXTERNAL RING SERIES/SIZE RANGE		*TIP NUMBER	*POWER PACK
SH	25-66	TIP-38	PTE-1
VSH	68-87	TIP-47	PTE-1
BSH	93-225	TIP-70	PTE-1
SHI	50-78	TIP-38	PTE-1
	81-100	TIP-47	PTE-1
SHR	106-250	TIP-70	PTE-1
	39-47	TIP-38	PTE-1
	50-66	TIP-47	PTE-1
DSH	75-98	TIP-70	PTE-1
	10mm-21mm	TIP-47	PTE-1
DST	21mm-55mm	TIP-70	PTE-1
	16mm-21mm	TIP-47	PTE-1
	22mm-55mm	TIP-70	PTE-1

Internal For use with the following retaining rings:



INTERNAL RING SERIES/SIZE RANGE		*TIP NUMBER	*POWER PACK
HO	125-287	TIP-70	PTI-1
VHO	125-287	TIP-70	PTI-1
BHO	125-287	TIP-70	PTI-1
HOI	81-250	TIP-70	PTI-1
DHO	26mm-98mm	TIP-70	PTI-1
	16mm-21mm	TIP-47	PTI-1
DHT	22mm-55mm	TIP-70	PTI-1

Please wear protective eyewear while installing and removing retaining rings & hose clamps.

Rotor Kick Jr. (RKJ) Automated Assembly Retaining Ring Tool

External
For use with the following retaining ring:



This ergonomic tool from Rotor Clip provides operator convenience and comfort along with efficient automated assembly. No electrical connections required. The tool is operated by air pressure for convenience and safety. And Carpal Tunnel Syndrome (CTS) injuries, caused by repetitive use of a manual tool, are eliminated. This hand-held tool is lightweight, portable and easy to use. A patented feeder mechanism, designed and built by Rotor Clip personnel, assures efficient, trouble-free operation.

Note: RG Rings must be purchased stacked for use with the Rotor Clip tool. Please inquire for size availability.



Hose Clamp Tools Manual

KC-18 Pliers
For use with single wire "HC" hose clamps:



Single Wire Hose Clamp Plier (KC-18)

Install Rotor Clamp Single Wire (HC) hose clamps quickly and easily using this simple hand tool. ONE SIZE FITS ALL. Specify **KC-18** for any Rotor Clamp Single Wire (HC) hose clamp you are installing.

HAZ-2 Pliers
For use with single wire "HC" hose clamps:

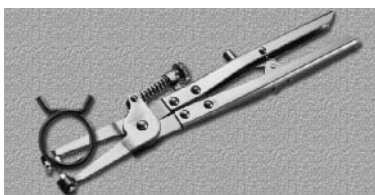

Single Wire Hose Clamp Plier - Heavy Duty (HAZ-2)

A heavy-duty version of the Single Wire Pliers (KC-18). Tool locks into place when clamp is fully compressed, relieving hand pressure when installing/removing. Tips can be adjusted to desired clamp opening to ensure fast, consistent installation or removal. ONE SIZE FITS ALL. Specify **HAZ-2** for any Rotor Clamp Single wire (HC) hose clamp you are installing.

HAZ-1 Pliers
For use with Constant Tension Band "CTB" hose clamps:



Constant Tension Band Hose Clamp Plier (HAZ-1)

A rugged easy-to-use application tool for CTB hose clamps. Tool locks into place when clamp is fully compressed, relieving hand pressure when installing/removing. Tips can be adjusted to desired clamp opening to ensure fast, consistent installation or removal. ONE SIZE FITS ALL. Specify **HAZ-1** for any Rotor Clamp Constant Tension Band (CTB) hose clamp you are installing.

Hose Clamp Tools Pneumatic

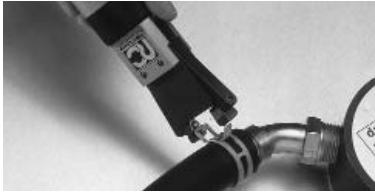

Pneumatic Hose Clamp Tools

Pneumatic Hose Clamp Tools use a compressed air line of 90 psi, and are activated by a simple lever reducing stress on the hand from repeated assembly/disassembly. Tangs of the clamp fit in the jaws of the tool and are compressed for installation or removal on the hose. Helps eliminate carpal tunnel syndrome.



PWS Pneumatic Tool

For use with Rotor Clamp Single Wire (HC/HW) hose clamps

Rotor Clamp HC No.	Pneumatic Installation Tool	Rotor Clamp HC No.	Pneumatic Installation Tool
HC-4	PWS-4	HC-19	PWS-19
HC-5	PWS-5	HC-19.5	PWS-19.5
HC-5.5	PWS-5.5	HC-20	PWS-20
HC-6	PWS-6	HC-21	PWS-21
HC-7	PWS-7	HC-22	PWS-22
HC-7.5	PWS-7.5	HC-23	PWS-23
HC-8	PWS-8	HC-24	PWS-24
HC-8.5	PWS-8.5	HC-25	PWS-25
HC-9	PWS-9	HC-26	PWS-26
HC-9.5	PWS-9.5	HC-28	PWS-28
HC-10	PWS-10	HC-30	PWS-30
HC-10.5	PWS-10.5	HC-31	PWS-31
HC-11	PWS-11	HC-32	PWS-32
HC-12	PWS-12	HC-34	PWS-34
HC-13	PWS-13	HC-35	PWS-35
HC-14	PWS-14	HC-36	PWS-36
HC-15	PWS-15	HC-38	PWS-38
HC-16	PWS-16	HC-40	PWS-40
HC-17	PWS-17	HC-42	PWS-42
HC-17.5	PWS-17.5	HC-46	PWS-46
HC-18	PWS-18	HC-50	PWS-50
HC-188	PWS-188		



Single Wire (HC/HW) Hose Clamp Pneumatic Tool (PWS). Designations for individual clamp sizes are listed left.



Double Wire (DW) Hose Clamp Pneumatic Tool (PWD). Designations for individual clamp sizes are listed left.



PWD Pneumatic Tool

For use with Rotor Clamp Double Wire (DW) hose clamps

Rotor Clamp DW No.	Pneumatic Installation Tool	Rotor Clamp DW No.	Pneumatic Installation Tool
DW-4.5	PWD-4.5	DW-17	PWD-17
DW-5	PWD-5	DW-17.5	PWD-17.5
DW-5.5	PWD-5.5	DW-18	PWD-18
DW-6	PWD-6	DW-19	PWD-19
DW-6.5	PWD-6.5	DW-19.5	PWD-19.5
DW-7	PWD-7	DW-20	PWD-20
DW-8	PWD-8	DW-21	PWD-21
DW-8.5	PWD-8.5	DW-22	PWD-22
DW-9	PWD-9	DW-22.5	PWD-22.5
DW-9.5	PWD-9.5	DW-23	PWD-23
DW-10	PWD-10	DW-24	PWD-24
DW-10.5	PWD-10.5	DW-25	PWD-25
DW-11	PWD-11	DW-26	PWD-26
DW-11.5	PWD-11.5	DW-27	PWD-27
DW-12	PWD-12	DW-28	PWD-28
DW-12.5	PWD-12.5	DW-30	PWD-30
DW-13	PWD-13	DW-31	PWD-31
DW-14	PWD-14	DW-32	PWD-32
DW-14.5	PWD-14.5	DW-34	PWD-34
DW-15	PWD-15	DW-35	PWD-35
DW-16	PWD-16	DW-36	PWD-36



PBC-1 Pneumatic Tool

For use with Rotor Clamp Constant Tension Band (CTB) hose clamps.



Specify **PBC-1** for any Rotor Clamp CTB Hose Clamp you are installing. One size fits all.



PRT Pneumatic Tool

For use with Rotor Clamp Constant Tension Band (CTB) hose clamps.



The PRT is an innovative application system for pre-opened hose clamps (CTO). It guarantees the perpendicular placement of the clamp to the hose and mating tube. It eliminates clamps placed at an angle which can possibly lead to leaks and loosening of the hose. Clamps cannot be closed until the tool is properly in place. The PRT verifies that the clamp has been cycled by sending a confirmation to an electronic work station. The tool is ergonomic and can fit into limited space requirements due to its unique design and adapts easily to standard assembly line air supply systems.

Please wear protective eyewear while installing and removing retaining rings & hose clamps.



Retaining Ring Plier Kits



Retaining Ring Plier Kits

Stock the tools you use the most with any or all of these four retaining ring plier kits. Rugged carrying cases provide portability and durability in a manufacturing/factory environment. Tools are designed to fit a wide range of sizes from 3/8" to 4" diameter retaining rings, meeting most everyday MRO requirements. Rotor Clip Plier Kits can be easily stored on a bench or in a maintenance cabinet/storage area. Descriptions and specifications follow.

Retaining Ring Plier Kits

For use with the following retaining rings:

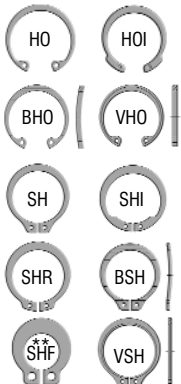

** Convertible Plier Kit only



Replaceable Tip Pliers Kit (RPK#1)

Contains one internal and one external plier in a reusable, clear plastic case. Features eight pair of replaceable tips that can be easily affixed to the end of

the pliers to cover internal/external retaining rings from 3/8" to 2" . . . Small enough to fit in your pocket!



Convertible Pliers Kit (RPK#3)

Contains 12 pliers which can be easily converted from internal to external and back again. Includes straight, 45° and 90° tip pliers that

will fit retaining rings up to 2" in diameter. Does the work of 24 individual tools!

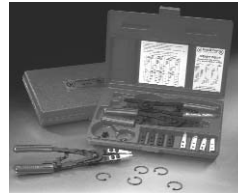

Ratchet Pliers Kit (RPK#2)

Features two ratchet pliers for internal/external retaining rings. Handles larger retaining rings up to 4". Ratchet mechanism compresses

(internal rings) and/or expands (external rings) through gradual steps, minimizing operator fatigue and effort.



Mini Convertible Pliers Kit (RPK#6)

This abbreviated version of the RPK#3 features 6 pliers in straight and 90° configurations that will fit retaining rings up to 2" in diameter.

Durable plastic case is easily stored in the tightest of spaces.



Retaining Ring Kits

RPK#4 Retaining Ring Kit

Contains the following styles of retaining rings:



Rotor Pack (RPK#4)



Rotor Pack features 1,000 retaining rings in four durable, clear-plastic boxes with easy snap on/off lids. Boxes fit into slots on a plastic holder which folds in half into a convenient, portable carrying case.

Rotor Pack contains internal ring sizes that will fit housings/bores from 3/8" in diameter to 1-1/8". External rings in the kit will accommodate shaft sizes from 1/4" to 1-1/8". Contains 2 pliers to fit every ring in the kit.

ROTOR PACK - RPK #4

Rotor Clip Number	Housing Dia. (In.)	Qty.	Rotor Clip Number	Shaft Dia. (In.)	Qty.
HO-37	3/8	50	SH-25	1/4	50
HO-43	7/16	50	SH-31	5/16	50
HO-50	1/2	50	SH-37	3/8	50
HO-56	9/16	50	SH-43	7/16	50
HO-62	5/8	50	SH-50	1/2	50
HO-75	3/4	50	SH-56	9/16	50
HO-87	7/8	50	SH-62	5/8	50
HO-100	1	50	SH-75	3/4	50
HO-112	1-1/8	50	SH-87	7/8	50
			SH-100	1	50
			SH-112	1-1/8	50

RPK#5 "E" Retaining Ring Kit

Contains the following styles of retaining rings:



Rotor Pack, Jr. (RPK#5)



Rotor Pack Jr. contains over 1,500 "E" retaining rings in four durable, clear plastic boxes with easy snap on/off lids. Boxes fit into slots on a plastic holder which folds in half into a convenient, portable carrying case.

Rotor Pack Jr. contains "E" rings accommodating shaft sizes from 1/16" in diameter to 1-3/16".

ROTOR PACK JR. - RPK#5

Rotor Clip Number	Shaft Dia. (In.)	Qty.	Rotor Clip Number	Shaft Dia. (In.)	Qty.
E-6	1/16	200	E-62	5/8	40
E-9	3/32	150	E-75	3/4	15
E-12	1/8	150	E-87	7/8	15
E-14	9/64	100	SE-9	3/32	150
E-15	5/32	100	SE-11	7/64	150
E-18	3/16	100	SE-17	11/64	100
E-25	1/4	50	SE-21	7/32	50
E-37	3/8	50	SE-31	5/16	50
E-43	7/16	50	SE-98	63/64	15
E-50	1/2	40	SE-118	1-3/16	12

Please wear protective eyewear while installing and removing retaining rings & hose clamps.

Automated Assembly Axial Rings



Automated Assembly is used in the manufacturing process as a cost reduction tool that additionally achieves increased production rate and added quality through repeatability. The same holds true for automated assembly of retaining rings. Parts can be assembled fast, reducing costs without sacrificing quality. Properly designed installation equipment shuttles the ring into the groove without disruption and guards against permanent set (overstretching/over-compressing of ring) to ensure a tight fit.

Design Considerations

Feed equipment should be designed to work with rings meeting standard specifications. Most critical is to design equipment that can accommodate the helix and pitch limitations for the type of ring you are using. If the equipment is sensitive to any of these factors, it will require special processing that will add to your costs. Design guidelines include:

1. Consider use of a tapered mandrel for external retaining rings and a tapered housing for internal retaining rings (see illustrations). It is not recommended to pick up and transfer rings by the lug holes.
2. Feed parts onto the tapered mandrel or into the tapered housing using a "feed finger" mechanism. Make sure the rings are fed in the proper direction and in the proper manner as depicted to avoid sensitivity to ring pitch.
3. Feed finger thickness should be sized per ring: 80% of the ring minimum thickness. (For example: If ring thickness is .025" +/- .002, feed finger should be .018" thick -- .023 X 80%.)
4. Limit shuttle distance to a minimum from feed mandrel to installation on assembly.
5. Do not incorporate extension sleeves to tapered mandrel/tapered housing. This may exceed the expansion/compression limits of the ring causing it to fail. (Note: extension sleeves are typically used to guard against scratching/marring the finish of the shaft or housing. If this is a concern, please consult Rotor Clip Technical Sales).
6. Incorporate complementary chamfers to the assembly and installation mandrels.

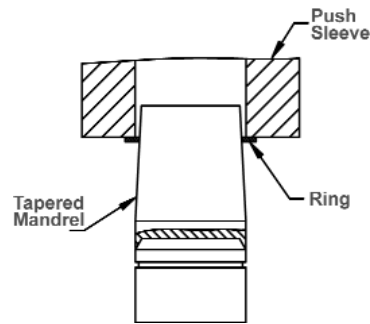

EXTERNAL

Use tapered mandrel to expand ring and install in groove on shaft. (Note: angle of inclination of taper should be 3-5 degrees).

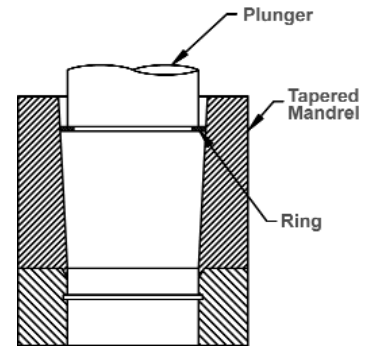

INTERNAL

Use tapered housing to compress ring and install in groove in housing. (Note: angle of inclination of taper should be 3-5 degrees).

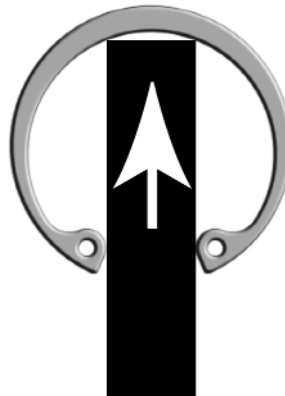

Figure A - This is the preferred way to transfer feed an internal ring into a tapered housing by inserting the mechanism between the lugs (Note: Finger thickness should be 80% of the minimum ring thickness).



Figure B - This is the preferred way to transfer feed an external ring onto a tapered mandrel by using a slide with a complementary cut out for the lugs. (Note: Finger thickness should be 80% of the minimum ring thickness).

Contact Technical Sales for more information:
tech@rotorclip.com
1.800.557.6867
+1 732.469.7333



Static Thrust Loads

1. ALLOWABLE THRUST LOADS - RINGS (P_r or P'_r)

Maximum allowable static thrust capacities for rings normally used with grooves are listed in the data charts for each ring type. The load limits are given for rings (P_r or P'_r) and grooves (P_g).

The values for P_r or P'_r are applicable only when the ring is installed in a housing or on a shaft made of hardened steel where the thrust load capacity of the groove is equal to or greater than that of the ring. When the ring is seated in a groove cut in softer material, and P_g is less than P_r or P'_r , P_g becomes the limiting factor in the assembly.

For maximum thrust capacity in both static and dynamic loading, the abutting face of the retained part should have a square corner. Fit of the retained part in the housing or on a shaft should allow reasonably concentric uniform loading against the ring.

When there is radial play between the retained part and the shaft or housing, such play must be treated as though the retained part had a chamfered corner. The magnitude of the chamfer should be considered equal to the play. Loading data for rings abutted by chamfered parts (P'_r) as shown in the specific ring data charts must be considered. (See CORNER RADII & CHAMFERS, page 257, right column.)

Allowable load capacities for rings (P_r) apply only to standard thickness rings made of standard materials using the shear strength values listed in Table 1, below, left.

When the following special materials are used, multiply the allowable thrust load of the ring by the conversion factor shown below.

Ring Material	Type	Rotor Clip Code	Conversion Factor All Sizes
Stainless Steel	PH 15-7Mo or equivalent AISI 632-AMS 5520	SS	1.0
Beryllium Copper*	Alloy = 25, UNS C17200	BC	0.75

* Except those noted in Table 1.

2. ALLOWABLE THRUST LOADS — GROOVES (P_g)

The allowable thrust loads listed in column P_g of the data charts for rings used in grooves are based upon a housing or shaft material of cold rolled steel with a tensile yield strength of 45,000 psi. In the case of Series VHO and VSH beveled rings, the values given are for minimum contact between ring and groove—i.e., engagement of the beveled edge of the ring with the beveled groove wall at a length equal to half of the groove depth ($d/2$).

When the following materials are used, multiply the allowable thrust load of the groove by the conversion factor shown below.

Groove Material	Tensile Yield Strength Type	Conversion Factor
Hardened Steel (RC-40)	150,000 psi	3.3
Hardened Steel (RC-50)	200,000 psi	4.45
Aluminum (2024-T4)	40,000 psi	0.89
Brass (Naval)	30,000 psi	0.66
Other	x psi	x psi/45,000

Table 1: Shear Strength of Ring Material

Material	Ring Series	Ring Thickness (in.)	Shear Strength (psi)	
Carbon Spring Steel (SAE 1060-1090)	HO	Up to and including .035	120,000	
	SH			
	BHO			
	BSH	.042 and over	150,000	
	VHO			
	VSH			
	HOI			
	SHI			
	C	.035 and over	150,000	
	SHR			
	SHM			
	Beryllium Copper (Alloy #25 UNS C17200)	LC	All available	150,000
RE				
PO/POL		.010 and .015	100,000	
BE				
E				
Beryllium Copper (Alloy #25 UNS C17200)		SH	.010 and .015 (Sizes -12 thru -23)	110,000
		BSH	.015 (Sizes -18 thru -23)	110,000
		E	.010 (Size -4 only)	95,000



Load Capacities Formulas

3. CALCULATING EDGE MARGIN

The distance from the groove to the end of the shaft or housing is known as edge margin. Edge margin is a calculated distance based on the relationship between the edge margin (y) and the groove depth (d). When $y/d \geq 3$, the groove will withstand the maximum thrust load as indicated in the Rotor Clip catalog specification page for that particular size and type of retaining ring.

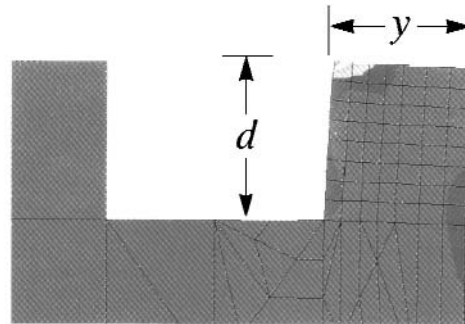

Example: SH-50 external retaining ring installed on a cold-rolled steel shaft. The catalog specifications for this ring call for a minimum edge margin of 0.048" and a groove depth of 0.016." Our formula is as follows:

$$y/d \geq 3 \frac{0.048''}{0.016''} = 3$$

There is sufficient edge margin for the groove to withstand the maximum thrust load of 550lbs. listed in the catalog specifications. If an application requires an edge margin less than the recommended specifications, it is necessary to calculate the thrust load (P_g)-capacity of the groove, to determine if the reduced margin is capable of handling the anticipated thrust load. The following formula applies (Note: see Correction Factors table for G_f value; Yield Strength of Groove Material for σ_y value; Edge Margin Graph for K_1 value; Nomenclature Table for remaining catalog specifications):

$$P_g = \frac{G_f D_s d \pi \sigma_y}{K_1 F_s}$$

For this example, assume that the edge margin will only be half the listed catalog value or, $y/d = 1.5$. The above equation is as follows:

$$\begin{aligned} P_g &= \frac{(1) .5 \times .016 \times 3.14 \times 45,000}{2.20 (2)} \\ &= \frac{1130.4}{4.40} \\ &= 256.9 \text{ lbs.} \end{aligned}$$

Maximum thrust load for reduced edge margin

Finite Element Analysis shows stress gradients for a retaining rings in an application with insufficient edge margin. When loaded, the high stress region extends over the entire groove wall to the end of the shaft (or housing) and the groove wall actually distorts. Under these conditions, the ring would buckle, possibly leading to catastrophic failure.

EDGE MARGIN

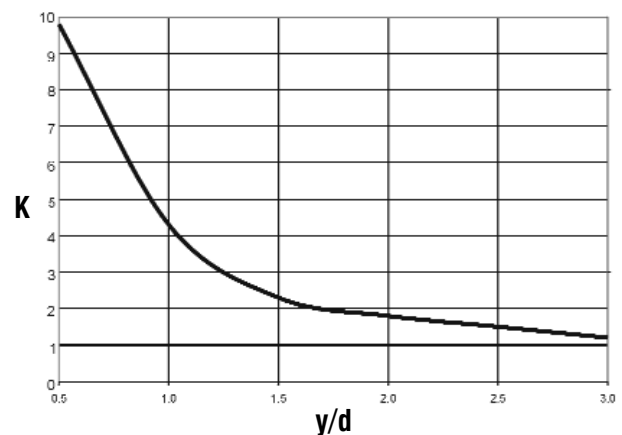

Yield Strength of Groove Material	
Groove Material	Yield Strength (psi)
Cold-drawn steel (SAE 1010)	45,000
Steel (SAE 1045, Rc 42)	185,000
Steel (SAE 1045, Rc 48)	220,000
Aluminum (2042-T4, Rb 75)	48,000
Naval Brass (Rb 82)	53,000

Correction Factors	
Ring Series	Correction Factor, G_f
HO, MHO	1.20
SHI, HOI	0.50
SH, MSH	1.00
C, MC	0.50
E, ME	0.33
RE, MRE	0.25
SHR, MSR	2.00
PO	0.50
SHM	1.00

Nomenclature Table	
d = Groove depth, in.	
D_s = Shaft or housing diameter, in.	
F_s = Safety Factor	
G_f = Correction Factor	
K_1 = Edge Margin	
P_g = Thrust Load on Groove, lb.	
σ_y = Tensile Yield Strength of groove material, psi	

**For Technical Assistance,
e-mail tech@rotorclip.com**



Formulas Load Capacities

4. THICKNESS OF HOUSINGS AND HOLLOW SHAFTS

The allowable load of a part in which a retaining ring groove is cut depends upon the ultimate tensile strength and tensile yield strength of the material used, and on the bearing area of the ring against the groove wall. For internal rings used in bores and housings — and external rings assembled on hollow shafts — wall thickness dimension w , illustrated below, can be calculated from the formulas:

For internal rings:

$$w = \sqrt{\frac{3G_f D_s d \sigma_y}{\sigma_u} + \frac{D_g^2}{4}} - \left[\frac{D_s}{2} \right]$$

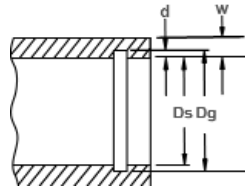

For external rings:

$$w = \frac{D_s}{2} - \sqrt{\frac{D_g^2}{4} - \frac{3G_f D_s d \sigma_y}{\sigma_u}}$$

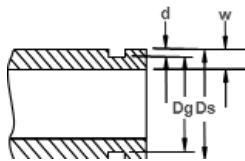

where:

- D_s = Shaft or housing dia. (in.)
- D_g = Groove dia. (in.)
- G_f = Correction Factor [See Table 2, Page 255]
- d = Groove depth (in.)
- σ_y = Tensile yield strength of groove material (psi)
[See Table 3, Page 258]
- σ_u = Ultimate tensile strength of groove material (psi)

These formulas provide for a wall thickness that is safe for allowable groove thrust loads (P_g) calculated with the formula at the right. If substantially lighter loads will be encountered and a thinner wall is desired, actual tests are recommended.

5. LOAD LIMIT FORMULAS

Formulas for determining ring and groove load limits — with sample calculations for Series HO internal rings and Series SH external rings — are given below. The loads are calculated for retained parts having sharp corners. Correction factors (G_f) for calculating P_r and P_g are given in Table 2 on right. The correction factors are based upon the load characteristics of the rings.

In these examples assume $y \geq 3d$. Therefore, $K = 1$ (see previous page) and is not shown in formulas for P_g .

Internal Ring (Example: Series HO-200)

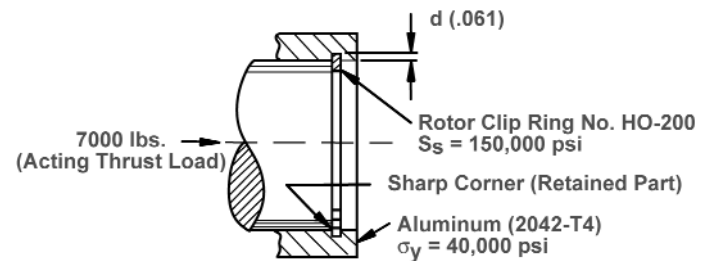

ALLOWABLE THRUST LOAD — RING (P_r in lbs.)

$$P_r = \frac{G_f D_h T \pi S_s}{F_s}$$

where:

- G_f = Conversion Factor [See Table 2, Page 255]
- D_h = Housing dia. (in.)
- T = Ring thickness (in.)
- S_s = Shear Strength of ring material (psi)
[See Table 1, Page 252]
- F_s = Safety factor

$$P_r = \frac{(1.2) 2.000 (.062) \pi 150,000}{4} = 17,500 \text{ lbs.} > 7000 \text{ lbs.}$$

**For Technical Assistance,
e-mail tech@rotorclip.com**



Load Capacities Formulas



ALLOWABLE THRUST LOAD — GROOVE (P_g in lbs.)

$$P_g = \frac{G_f D_h d \pi \sigma_y}{F_s}$$

where:

G_f = Correction Factor [See Table 2, right]

D_h = Housing dia. (in.)

d = Groove depth (in.)

σ_y = Tensile yield strength of groove material (psi)
[See Table 3, Page 258]

F_s = Safety factor

$$P_g = \frac{(1.2) 2.000 (.061) \pi 40,000}{2} = 9200 \text{ lbs.} > 7000 \text{ lbs.}$$

ALLOWABLE THRUST LOAD — GROOVE (P_g in lbs.)

$$P_g = \frac{G_f D_s d \pi \sigma_y}{F_s}$$

where:

G_f = Conversion Factor [See Table 2, below]

D_s = Shaft dia. (in.)

d = Groove depth (in.)

σ_y = Tensile yield strength of groove material (psi)
[See Table 3, Page 258]

F_s = Safety factor

$$P_g = \frac{(1) 1.000 (.030) \pi 45,000}{2} = 2100 \text{ lbs.} > 2000 \text{ lbs}$$

Note: For series RE only: Substitute value of groove diameter (D_g) for shaft diameter (D_s)

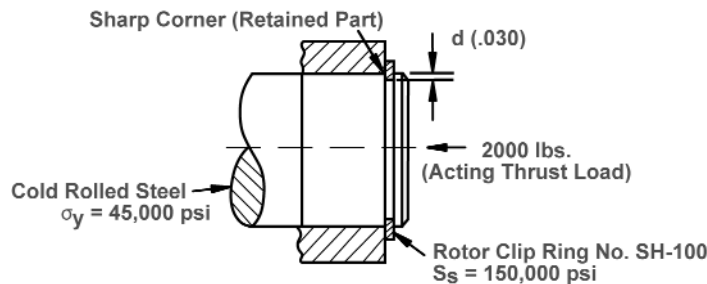

Table 2: Correction Factors (G_f) for Calculating P_r and P_g

Ring Series	Correction Factor G_f	
	Ring: P_r	Groove: P_g
HO, BHO, MHO	1.2	1.2
VHO	1.2	1.2 (Use $d/2$ instead of d)
HOI, SHI	2/3	1/2
SH, BSH, MSH	1	1
VSH	1	1 (Use $d/2$ instead of d)
C, MC	1/2	1/2
LC	3/4	3/4
BE, E, ME	1/3	1/3
RE, MRE	1/4	1/4
EL	Use listed data chart values	1/2
SHR, MSR	1.3	2
PO	1/2	1/2
SHM	Inquire	1

External Ring (Example: Series SH-100)

ALLOWABLE THRUST LOAD — RING (P_r in lbs.)

$$P_r = \frac{G_f D_s T \pi S_s}{F_s}$$

where:

G_f = Conversion Factor [See Table 2, right]

D_s = Shaft dia. (in.)

T = Ring thickness (in.)

S_s = Shear Strength of ring material (psi)
[See Table 1, Page 252]

F_s = Safety factor

$$P_r = \frac{(1) 1.000 (.042) \pi 150,000}{4} = 4950 \text{ lbs.} > 2000 \text{ lbs}$$





Dynamic Thrust Loads

Dynamic conditions most often encountered in retaining ring assemblies include sudden loading, impact, vibration, and relative rotation. Very often the loading pattern is cyclical in nature and may induce fatigue in the assembly. Where dynamic loads are likely to exist, it is necessary that actual tests of such applications be made by the ring user to insure proper functioning of the assembly. The following formulas are given for calculating the ring and or groove thrust load capacity for various conditions.

1. SUDDEN LOADING

This can occur when a surge in thrust load is transmitted to a ring installed in a tight assembly, without play between the retained part and the ring. Sudden loads of this nature should not exceed, at their maximum, 50% of the allowable static thrust load (P_r or P_g , whichever is lower).

2. IMPACT LOADING

To calculate the safe impact load capacity of the ring (I_r), the following formula should be used:

$$I_r = \frac{P_r t}{2}$$

where: I_r = Allowable impact load (in. lbs.)
 P_r = Allowable thrust load of ring (lbs.)
 t = Ring thickness (in.)

The formula for calculating the safe impact load capacity of the groove (I_g) is:

$$I_g = \frac{P_g d}{2}$$

where: I_g = Allowable impact load (in. lbs.)
 P_g = Allowable thrust load of groove (lbs.)
 d = Nominal groove depth (in.)

• External Ring (Example: Series SH-200)

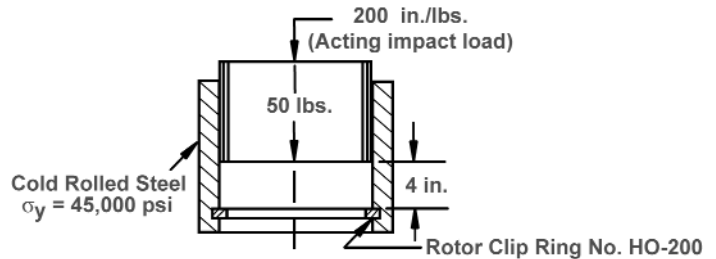

FOR THE RING: $I_r = \frac{P_r t}{2} = \frac{17,500 (.062)}{2}$
 $= 540 \text{ in. lbs.} > 200 \text{ in. lbs.}$

FOR THE GROOVE: $I_g = \frac{P_g d}{2} = \frac{10,400 (.061)}{2}$
 $= 320 \text{ in. lbs.} > 200 \text{ in. lbs.}$

3. VIBRATION LOADING

It is possible to calculate the approximate vibration load capacity of a ring and groove if there is a tight fit between the ring and the abutting retained part. (If there is space between the ring and the part, the load capacity must be calculated as impact.)

The formula for calculating the vibration load capacity of the ring is: $wa \leq 540 P_r$

where: w = Weight of retained parts (lbs.)
 a = Acceleration of parts (in./sec.²)
 P_r = Allowable thrust load of ring (lbs.)

To calculate the vibration load capacity of the groove, the formula is: $wa \leq 400 P_g$

where: w = Weight of retained parts (lbs.)
 a = Acceleration of parts (in. sec.²)
 P_g = Allowable thrust load of groove (lbs.)



Load Capacities Formulas

Harmonic oscillation for both ring and groove may be calculated with the following formula: $a \cong 40 pf^2$

where: a = Acceleration of parts (in./sec.²)
 p = Amplitude (in.)
 f = Frequency (cycles/sec.)

• Sample Calculation (Example: Series SH-200)

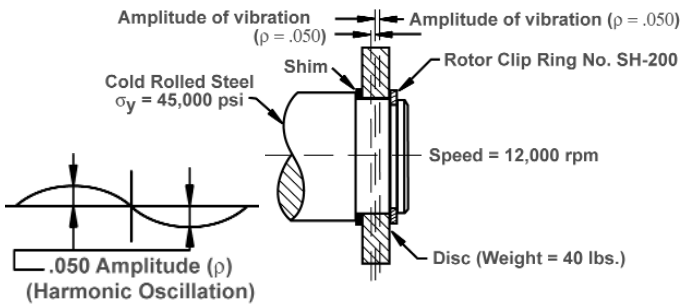

FOR THE RING: $wa \leq 540 P_r$

For harmonic oscillation:

$$a \cong 40 pf^2$$

$$f = \frac{12,000}{60} = 200 \text{ cycles/sec.}$$

$$a \cong 40 (.050) 200^2 = 80,000 \text{ in./sec.}^2$$

$$wa = (40) (80,000) = 3.2 \times 10^6$$

$$540 P_r = (540) (14,600) = 7.9 \times 10^6$$

$\therefore wa < 540 P_r$ and ring is safe

FOR THE GROOVE:

$$wa \leq 400 P_g$$

$$wa = 3.2 \times 10^6$$

$$400 P_g = (400) (8050) = 3.22 \times 10^6$$

$\therefore wa < 400 P_g$ and groove strength is adequate.

Corner Radii and Chamfers - R_{max} and Ch_{max}

All of the formulas above and the values for P_r given in the data charts for each ring type are calculated for assemblies in which the retained parts have square corners. If the abutting face of the retained part has a corner radius or chamfer, the assembly's thrust load capacity will be lower. A Series HO-100 ring which abuts a square-cornered part, for example, has a static thrust capacity of 5,950 lbs. The same ring, seated next to a part having the maximum allowable corner radius or chamfer, has an allowable load of 1,650 lbs.

Maximum allowable corner radii and chamfers for each ring size are listed in the charts with corresponding static thrust capacities. If these thrust capacities are not sufficient for the assembly, a rigid square-cornered flat washer should be inserted between the part and the ring. The thrust capacity of the assembly will then be approximately the same as if a square-cornered retained part had been used.

When the actual corner radius or chamfer is less than the listed maximum, the allowable thrust load of the assembly increases proportionately in accordance with the following formulas:

$$P''_r = P'_r \frac{R_{max.}}{R} \quad (\text{for radius})$$

$$P''_r = P'_r \frac{Ch_{max.}}{Ch} \quad (\text{for chamfer})$$

where: P''_r = Allowable assembly load when corner radius or chamfer is less than listed maximum
 P'_r = Listed allowable assembly load with maximum corner radius or chamfer
 $R_{max.}$ = Listed maximum allowable corner radius
 R = Actual corner radius
 $Ch_{max.}$ = Listed maximum allowable chamfer
 Ch = Actual chamfer

(Continued on next page...)



Formulas Load Capacities

Corner Radii and Chamfers - R_{max} and Ch_{max}

Continued...

- Sample Calculation (Example: Series SH-125)

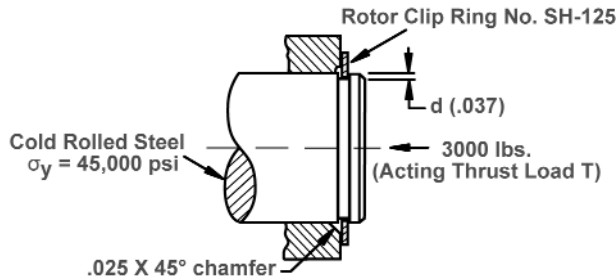

ALLOWABLE THRUST LOAD — RING (P''_r in lbs.)

$$P''_r = P'_r \frac{Ch_{max.}}{Ch} = \frac{(1950) (.041)}{.025}$$

$$P''_r = 3200 \text{ lbs.} > 3000 \text{ lbs.}$$

ALLOWABLE THRUST LOAD — GROOVE (P_g in lbs.)

$$P_g = \frac{G_f D_s d \pi \sigma_y}{F_s} \quad (\text{See formula derivation page 253})$$

$$P_g = \frac{(1)1.250(.037) \pi (45,000)}{2}$$

$$P_g = 3270 \text{ lbs.} > 3000 \text{ lbs.}$$

NOTE: If the allowable thrust load capacity of the ring (P_r) or the groove (P_g) is less than P''_r , P_r or P_g — whichever is lower — becomes the limiting factor in the assembly.

ELASTIC DEFORMATION WITH CORNER RADII OR CHAMFERS

Elastic deformation of an assembly (retained part, retaining ring and groove wall) where the retained part has a corner radius or chamfer can be calculated with the following formulas:

$$\delta = \frac{T (.01) D_s (R + t/4)}{(P''_r) t} \quad (\text{for radius})$$

$$\delta = \frac{T (.01) D_s (Ch + t/4)}{(P''_r) t} \quad (\text{for chamfer})$$

where: δ = Deflection (in.)

T = Acting thrust load (lbs.)

D_s = Shaft or housing dia. (in.)

R = Actual radius (in.)

Ch = Actual chamfer (in.)

t = Ring thickness (in.)

P''_r = Allowable thrust load of ring when actual corner radius or chamfer is less than listed maximum (lbs.)

NOTE: R and Ch cannot exceed the values for R_{max} and Ch_{max} listed in the data charts for the individual ring types.

- Sample Calculation (Example: Series SH-125)

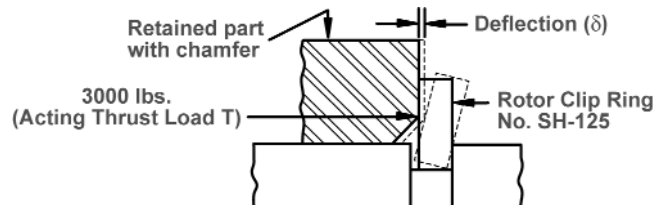

$$\delta = \frac{T (.01) D_s (Ch + t/4)}{(P''_r) t}$$

$$\delta = \frac{(3000) (.01) (1.250) (.025 + .0125)}{(3200) (.050)} \cong .0087 \text{ in.}$$

Table 3: Tensile Yield Strength of Groove Material

Groove Material	Tensile Yield Strength (psi)
Cold-drawn steel (SAE 1010)	45,000
Hardened steel (RC-40)	150,000
Hardened steel (RC-50)	200,000
Steel (SAE 1045, Rc 42)	185,000
Steel (SAE 1045, Rc 48)	220,000
Aluminum (2024-T4)	40,000
Aluminum (2042-T4, Rb 75)	48,000
Naval Brass	30,000
Naval Brass (Rb 82)	53,000

Table 4: Maximum Working Stress of Ring During Expansion or Contraction

Ring Material	Rotor Clip Code	Maximum Allowable Working Stress (psi)
Carbon Spring Steel (SAE 1075)	ST	250,000
Stainless Steel (PH 15-7 Mo)	SS	250,000
Beryllium Copper (Alloy #25)	BC	200,000



Relative Rotation

When a retained part rotates relative to and exerts thrust on the ring, frictional forces act on the ring body. Relative rotation can reduce substantially the thrust capacity of the assembly. The use of a keyed washer or other non-rotating device between ring and retained part to eliminate relative rotation should be considered.

To prevent the rings from being “walked out” or otherwise unseated from the groove, maximum allowable rotating thrust loads may be calculated from the following formula:

$$P_{rr} \leq \frac{s t E^2}{\mu 18 D_S}$$

where: P_{rr} = Allowable thrust load exerted by adjacent part (lbs.)
 s = Maximum working stress of ring during expansion or contraction [See Table 4, left]
 t = Ring thickness (in.)
 E = Largest section of ring (in.)
 μ = Coefficient of friction between ring and retained part or groove whichever is higher (consult appropriate references)
 D_S = Shaft or housing dia. (in.)

- Sample Calculation (Example: Series SH-150)

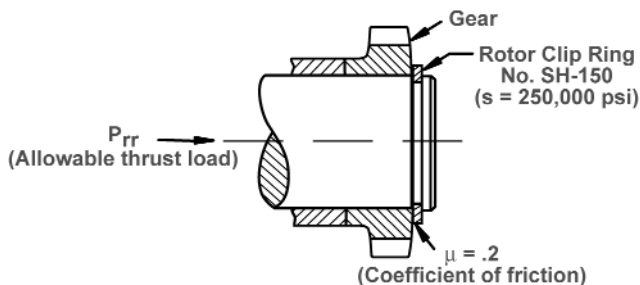

$$P_{rr} \leq \frac{s t E^2}{\mu 18 D_S}$$

$$P_{rr} \leq \frac{250,000 (.050) (.168)^2}{.2 (18) (1.500)} = 65 \text{ lbs. max.}$$

NOTE: Relative rotation applies to the following rings made of standard materials when used in grooves: Series HO, BHO, VHO, HOI, SH, BSH, VSH, C,SHI, BE, E, RE, SHR, PO, SHF and SHM. Series LC and EL are not affected.

Deflection

Permanent deflection of ring assemblies (retained part, retaining ring and groove wall), permitting movement of the retained parts, is negligible when loads do not exceed the governing allowable thrust load (static, impact, vibration, etc. — whichever is present).

Elastic deformation, which is a temporary displacement of the retained part under load, can be calculated by the following formula:

$$\delta = \frac{T}{E d}$$

where: δ = Deflection (in.)
 T = Acting load (lbs.)
 E = Modulus of elasticity of groove material
 d = Groove depth (in.)

- Sample Calculation (Example: Series SH-100)

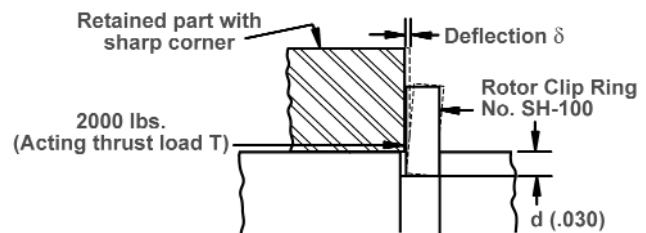

$$\delta = \frac{T}{E d} = \frac{2000}{3 \times 10^7 (.030)} = .0022''$$

**For Technical Assistance,
 e-mail tech@rotorclip.com**



Formulas Beveled Retaining Rings

The purpose of beveled rings, when used within their specified limits, is to assure the user that in all assemblies there will always be an axial force exerted on the retained part by the retaining ring. This concept is illustrated below:

$$\text{Ring take-up capability } [d/2 (\tan 15^\circ)] \geq \Delta A + \Delta B + \Delta U$$

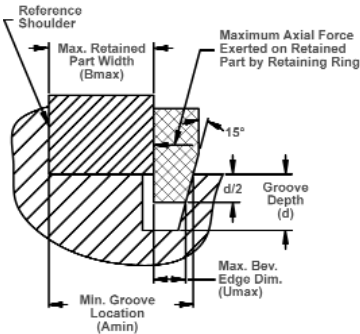
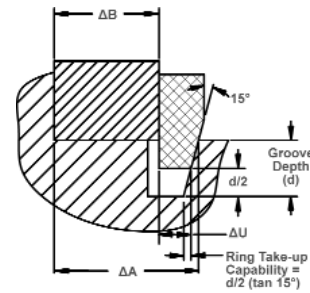

Ring Seated at Minimum Depth

If the take-up requirement is satisfied, the groove location limits (Amin & Amax) can be calculated as follows:

$$A_{min} = B_{max} + U_{max} + d/2 (\tan 15^\circ)$$

$$A_{max} = B_{min} + U_{min} + d (\tan 15^\circ)$$

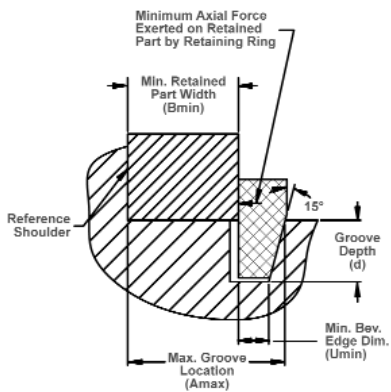

Ring Seated at Maximum Depth (Near Groove Bottom)

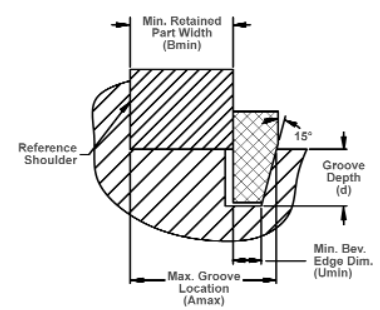
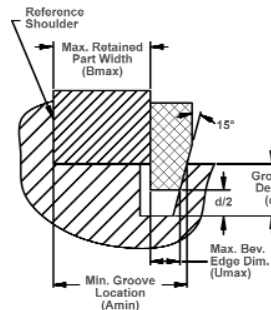

As an example of this technique, assume that a VHO-200 ring is used to retain a part with a width dimension of $1.000 \pm .002$.

The groove location limits will be as follows:

$$A_{min} = 1.002 + .045 + .072/2 (\tan 15^\circ) = 1.057$$

$$A_{max} = .998 + .043 + .072 (\tan 15^\circ) = 1.060$$

If the user's ability to locate the groove requires less than the .003 allowable tolerance, the maximum seating depth position can be moved up the groove to provide a higher minimum axial force.

Until now, the explanation has focused on a technique which will assure that 100% of the assemblies will have the ring seated within the limits shown. If the user will accept a statistically small number of assemblies (2 out of 1000) with the ring seating slightly outside of these limits, the statistical groove location technique can be used. This will provide slightly more take-up than the technique described above. Please contact the Rotor Clip Engineering Department for information about this concept.

In almost all applications, the ring will seat at depth somewhere in between the limits shown.

The allowable "take-up" capability of a ring is its ability to compensate for the dimensional variation of the components in an assembly. Whether a beveled ring can be used in this way depends on two factors:

1. The summation of the three relevant tolerances which determine the take-up required. As can be seen in the drawing (upper right), these parameters are the variation in retained part width (ΔB), groove location (ΔA), and ring beveled edge (ΔU). For simplicity of analysis, the groove and ring 15° angles are assumed to have no variability.
2. The capability of the ring to provide take-up or compensation for the variability of the assembly components listed above. For the ring to provide sufficient take-up to compensate for the variability, and to seat within the limits $d/2$ to d , the following requirement must be satisfied:



Bowed Retaining Rings **Formulas**

SERIES BHO, BSH, BE and EL RINGS

To obtain the maximum resilient end-play take-up which bowed rings offer, it is necessary to locate grooves carefully. Formulas for calculating the location of the load-bearing wall of the groove with respect to any plane of reference are as follows:

$$A_{\max} = B_{\min} + J_{\max}$$

$$A_{\min} = B_{\max} + J_{\min}$$

$J_{\max} - J_{\min}$ = resilient take-up of tolerances of groove location A and width B of retained part (see drawings below and right.)

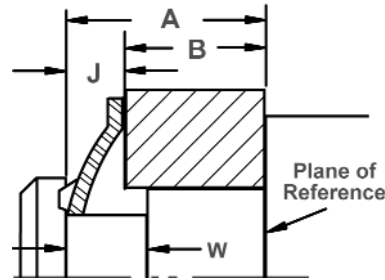

EL Series
Bowed Locking Series

The thickness tolerance, residual bow height and minimum bow height of the ring are used to determine the J_{\min} and J_{\max} spacing dimensions.

In cases where the tolerances of width B of the retained part are large, the tolerances of groove location A will be small. In many cases, groove width W has no effect on ring function provided it is larger than the listed minimum. The groove width may be increased considerably, in fact, with no effect on ring function as long as the rear wall of the groove remains under the retained part.

J_{\min} and J_{\max} , the dimensions used to control groove location, are set so that the rings will not flatten completely during installation. Even after flattening under the load listed in the data charts as "Force Needed to Flatten," the rings will retain sufficient bow height to take up end-play resiliently within the limits of J_{\min} and J_{\max} .

Series BHO, BSH and BE bowed rings will retain their tight grip against the groove bottom even under loads exceeding the "Force Needed to Flatten" and will then provide thrust load capacities equivalent to the corresponding flat standard internal and external rings.

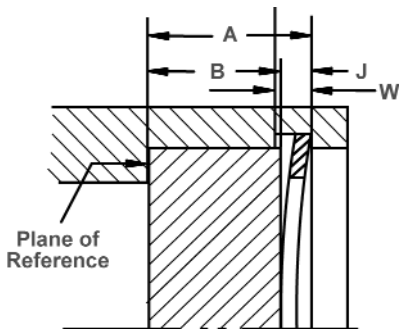

BHO Series
Bowed Internal Rings

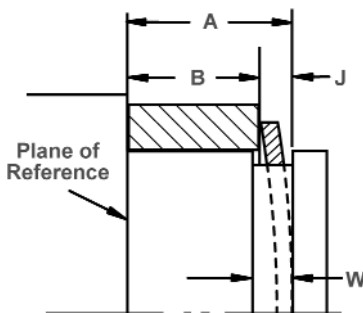

BSH Series
Bowed External Ring

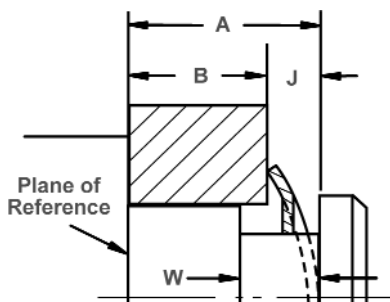

BE Series
Bowed E-Ring



Inspection Procedures

DETERMINING PERMANENT SET LIMITS FOR BASIC EXTERNAL RETAINING RINGS

SH, VSH, SHI

1. Measure thickness (designated as "T" in specification charts) of the ring for adherence to specified tolerances.
2. Using a Rotor Clip retaining ring plier, separate the lugs until the ring barely fits over a shaft 1% larger than the nominal shaft diameter. Repeat this procedure four additional times using the same ring. Examine the ring for cracks.
3. Measure ring diameter (D) in three directions as indicated below.

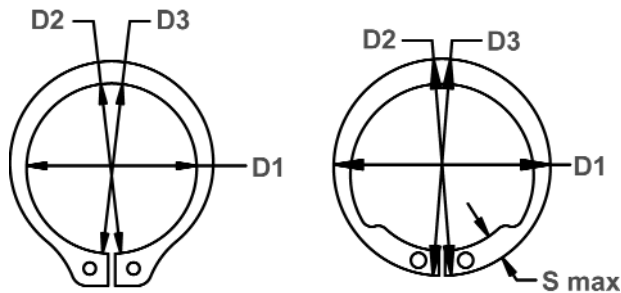

4. **FOR SH AND VSH RINGS** - Take the results of these three measurements and compute the average. Compare this figure to the minimum groove diameter listed in the specification chart for SH and/or VSH rings. If the average diameter after permanent set is less than the groove diameter, THEN THE RING IS FULLY FUNCTIONAL AND WILL PERFORM ACCORDING TO STATED SPECIFICATIONS:

Average Diameter < Minimum Groove Diameter ("Dg" in Spec Chart)

5. **FOR SHI RINGS** - Take the results of the three diameter measurements described in #3 above and compute the average. Measure the maximum section ("S max" in the spec charts). Compare the average diameter minus 2 times "S max" to the minimum groove diameter listed in the specification chart for SHI rings. If the average diameter minus twice the maximum section after permanent set is less than the groove diameter, THEN THE RING IS FULLY FUNCTIONAL AND WILL PERFORM ACCORDING TO STATED SPECIFICATIONS:

Average Diameter - 2S max < Minimum Groove Diameter ("Dg" in Spec Chart)

DETERMINING PERMANENT SET LIMITS FOR BASIC INTERNAL RETAINING RINGS

HO, VHO, HOI

1. Measure thickness (designated as "T" in specification charts) of the ring for adherence to specified tolerances.
2. Using a Rotor Clip retaining ring plier, compress the lugs fully until they touch. Repeat this procedure four additional times using the same ring. Examine the ring for cracks.
3. Measure ring diameter (D) in three directions as indicated below.

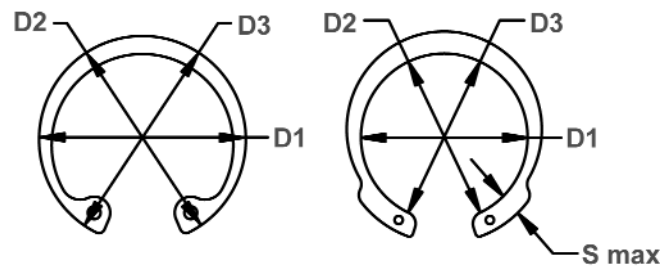

4. **FOR HO AND VHO RINGS** - Take the results of these three measurements and compute the average. Compare this figure to the maximum groove diameter listed in the specification chart for HO and/or VHO rings. If the average diameter after permanent set is GREATER than the groove diameter, THEN THE RING IS FULLY FUNCTIONAL AND WILL PERFORM ACCORDING TO STATED SPECIFICATIONS:

Average Diameter > Maximum Groove Diameter ("Dg" in Spec Chart)

5. **FOR HOI RINGS** - Take the results of the three diameter measurements described in #3 above and compute the average. Measure the maximum section ("S max" in the spec charts). Compare the average diameter plus 2 times "S max" to the maximum groove diameter listed in the specification chart for HOI rings. If the average diameter plus twice the maximum section after permanent set is GREATER than the groove diameter, THEN THE RING IS FULLY FUNCTIONAL AND WILL PERFORM ACCORDING TO STATED SPECIFICATIONS:

Average Diameter + 2S max > Maximum Groove Diameter ("Dg" in Spec Chart)



LIMITATIONS – DISH, PITCH & BURR

Rotor Clip retaining rings meet accepted industry parameters for limitations of dish and pitch. These characteristics are illustrated below.

1. DISH LIMITATIONS

Dish is any difference in height occurring from the outer edge of the ring to the inner edge. This condition should be considered separate from Pitch (see #2). To determine Dish, a small amount of weight can be applied to the upper surface of the ring to remove pitch from the overall height measurement.

DISH LIMITATIONS-For Internal, External & Radial Rings

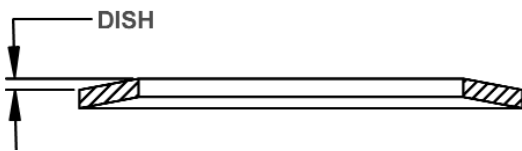

Ring Thickness (In.)	Allowable Dish (In.)
0.010-0.015	0.002
0.025-0.035	0.003
0.042-0.093	0.005
0.109-0.125	0.010
0.156-0.187	0.015

2. PITCH LIMITATIONS

Pitch takes into account thickness of the ring including any mismatching of lugs, where applicable.

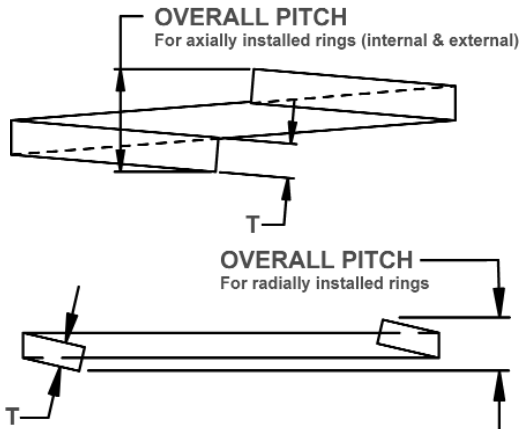

PITCH LIMITATIONS

Ring Size (In.) For Shafts/Bores	Internal & External Retaining Rings Maximum Overall Pitch	Radial Retaining Rings
ALL SIZES	3T	-
UP TO 1/2"	-	1.5T
OVER 1/2"	-	2T

3. BURR LIMITATIONS

A burr results from the metal stamping process. It is a raised edge for which the following parameters apply.

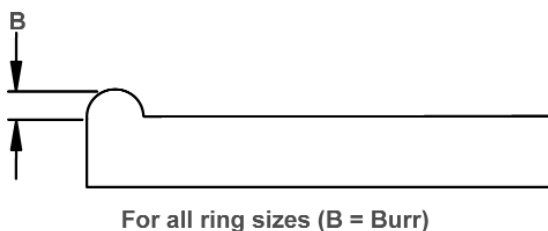

BURR LIMITATIONS

Material Thickness (In.)	Maximum Allowable Burr (In.)
0.010-0.020	0.001
0.025	0.0015
0.035-0.109	0.002
0.125 & Over	0.003



Inspection Procedures

INSPECTION PROCEDURES FOR CONSTANT SECTION RETAINING RINGS

Measure the ring for the parameters indicated and compare them to the dimensions listed in the specification pages for that particular ring. **NOTE: ALL DIMENSIONS ARE TAKEN IN THE FREE STATE EXCEPT FOR THE GAP, WHICH IS MEASURED ONCE THE RING IS INSTALLED.**

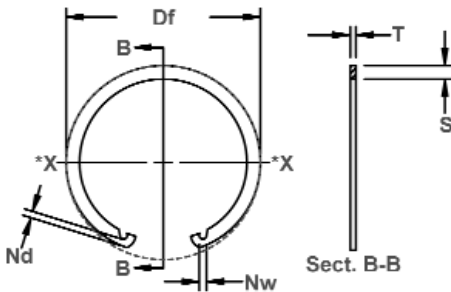

*Df measured in this direction only.

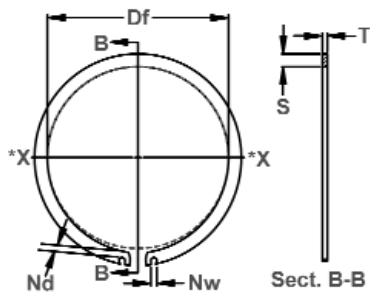

*Df measured in this direction only.

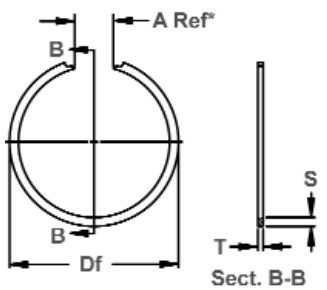

*These dimensions are measured with the ring installed in the groove.

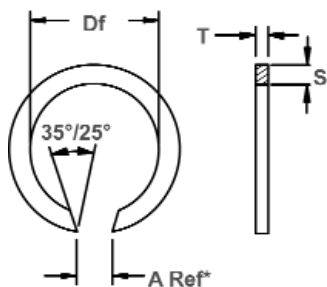

*These dimensions are measured with the ring installed in the groove.

CONSTANT SECTION RING "KICK-IN" FEATURE

Constant Section retaining rings become elliptical when deformed making three-point contact with the groove (see drawing). Two of these contact points are the ends, which seat deeply into the groove making it extremely difficult to install/remove in an application.

This is particularly troublesome for the standard internal (UHO) and external (USH) rings since they depend upon the accessibility of the notches for installation/removal. In fact, the configuration of the standard ring renders these rings practically unusable in any kind of manual assembly operation.

Rotor Clip's "kick-in/out" feature solves this problem. By kicking in the lugs, installation into a housing/bore (UHO) is much easier since the lugs are more accessible using a manual tool. The same is true for removing the ring.

By kicking out the lugs, installation onto a shaft (USH) is also easier due to the greater accessibility of the lugs.

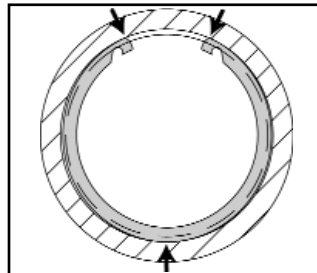

Internal (UHO) ring makes three-point contact with the groove of a housing.

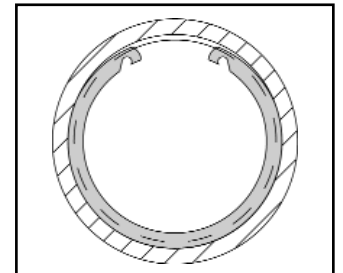

"Kick in" feature renders lugs more accessible for easier installation and removal.

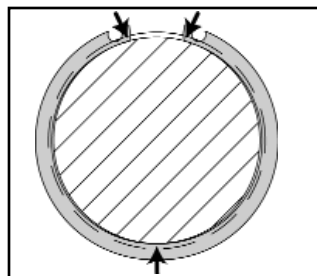

External (USH) ring makes three-point contact with the groove of a shaft.

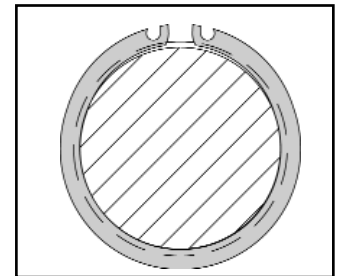

"Kick out" feature makes lugs more accessible for easier installation and removal.



Retaining Ring Definitions



Tapered Retaining Rings—Rotor Clip basic rings have a tapered section which decreases symmetrically from the center to the free ends. As a result, basic internal and external rings remain circular when contracted or expanded within the limits of normal use. This assures contact with the groove along the entire periphery of the ring (a key factor in obtaining high thrust capacity).

Constant Section Retaining Rings—These rings have a uniform section height. When they are contracted or expanded, they take on an oval deformation (rather than circular, like tapered rings). As a result, they contact the groove bottom at three or more isolated points, but never continuously around the periphery.

Spiral Retaining Rings—These make 360 degree contact with the groove in a housing or on a shaft. However, they accommodate less force than a tapered ring and are more difficult to install/remove.



Spiral Retaining Rings.

Inverted Lugs—Allows more clearance on a shaft or in a housing; the lugs also abut the bottom of the groove.

Self-Locking Rings—Rings that can be installed on a shaft or in a housing/bore without using a groove.

Resilient Endplay Take-Up—Refers to “bowed” retaining rings; once installed in a groove they act like springs providing resilient endplay take-up.

Rigid Endplay Take-Up—Refers to “beveled” retaining rings; once installed in a groove they “lock” an assembly into place providing rigid endplay take-up.

Axial retaining rings—Installed in an axial (horizontal) direction in a housing/bore or on a shaft.

Radial Retaining Rings—Installed in a radial (vertical) direction on a shaft.



Radial Installation.

Retaining Ring Pliers—For retaining rings with lug holes—the tips of these special tools are inserted into the lug holes and compressed (internal) for installation in a housing or expanded (external) for installation over a shaft.



Applicators—Used to install radial retaining rings onto a shaft.

Dispensers—Dispenses stacked radial retaining rings onto an applicator.

Permanent Set—This occurs when a ring has been deformed beyond its elastic limits and does not return to its original condition, resulting in its failure to seat properly in the groove.

Thrust Load Capacity—The amount of force a retaining ring will accommodate once installed in a groove.

Edge Margin—The distance from the groove to the end of the shaft or housing.

Rings On Wire—A method of stacking retaining rings by threading a wire into both lug holes of internal and external retaining rings.

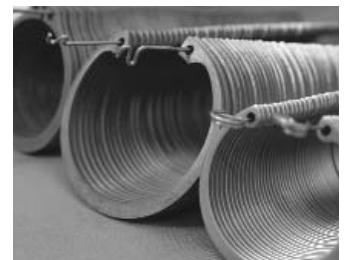

Rings On Wire.

Salt Spray—Corrosion test performed in a humidity chamber to simulate seashore conditions, or to accelerate corrosion at a controlled rate.



Design Considerations Retaining Ring

TWO OVERALL RULES FOR SELECTING THE RIGHT RETAINING RING FOR YOUR APPLICATION

1. Consider the ring as an integral part of your design from original concept through prints and prototypes. If you work this way, chances are you'll be able to use smaller, lighter components for substantial cost savings. And you'll be able to use one of our standard ring designs, which is a lot more economical than finding later you need an expensive, custom-designed fastener.
2. Think ahead to the assembly line: how will the ring be installed - by hand, semi-automatically or with mechanized tools - in relation to other manufacturing operations. This can save you a great deal of time and effort, and avoid problems when you go into production.

BASIC CONSIDERATIONS

1. **Size** - Bore, housing and shaft diameters will determine the size of the rings you can use.



2. **Axial or Radial assembly** - Internal rings are used to position and secure parts in bores and housings. They are always installed in an axial direction. External rings hold parts on shafts, studs and similar devices and can be installed in both axial and radial directions.

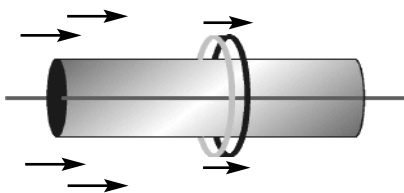

Axial Assembly

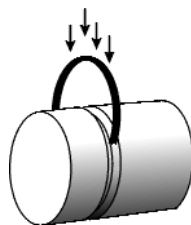

Radial Assembly

3. **Load capacity** - Maximum allowable static thrust load capacities for all rings are listed in the catalog pages for all Rotor Clip rings. If a ring is seated in a groove cut in material softer than the ring, the thrust load capacity of the groove ("Pg" in the ring data charts) becomes the limiting factor in the assembly. If the ring is installed in a housing or on a shaft made of hardened steel, the maximum allowable static thrust load capacity of the ring (Pr) may be used.

Importance of load capacity to your design - If you need rings to position and secure bearings in a pump, or lock up components in a car or truck transmission, load capacity can be critically important for function, safety and reliability of the ring application. On the other hand, if you plan to use a ring merely to hold a plastic wheel on the axle of a toy truck, chances are you won't have to worry about loads on the ring. All you really need is a ring that will stay put once you have it positioned. It is pointless to "over design" for high load capacity and pay the price for both rings and grooves when another ring will do the job less expensively. So take a hard look at your load capacity requirements before making any ring selections. As we indicated earlier, you'll find everything you need to know in the Rotor Clip Catalog.

4. **Assembly Clearance** - Clearance for retaining rings is important for several reasons. You can choose a specific type that meets all your design requirements, but if you haven't got room to install it on the production line, you've got a problem. The same holds true for removing and re-assembling a ring during inspection, field service or repairs.

Axial and radial clearance also must be considered in relation to abutting or adjacent components in the assembly. If the lugs of a Series SH basic external ring get in the way of other parts, for example, you might use an inverted Series SHI. You have the same kind of options with radial rings. A Series E ring, for example, might be replaced with a C ring. The LC two-part interlocking rings also assure maximum clearance.

Retaining Ring Design Considerations

5. Types of Axial/Radial Rings - The basic internal/ and external (HO/SH) rings provide heavy thrust load capacities.

- The inverted versions of these rings have lower thrust load capacity but provide better clearance and form a higher uniform shoulder good for retaining bearings and other components with large corner radii or chamfers.
- Radial rings generally have lower thrust load capacity but speed assembly where the parts being retained are more accessible; they also form larger shoulders against the retained parts. These are general rules, however, and there are exceptions; e.g., Series PO and POL retainers are radial rings with substantially greater gripping strength than some axial rings.
- Series LC two-part interlocking rings were designed for high rotational speeds and provide a more attractive appearance than some axial types.

6. End-Play Take-Up Rings -

In many products, accumulated tolerances or wear in the retained parts can cause objectionable end-play in the assembly. There are two types of rings you can use to avoid this: Rotor Clip bowed rings are designed to provide resilient take-up by functioning as both spring and fastener. In addition to compensating for end-play, they also can be used to dampen vibration and oscillation. They are available in several different types for axial or radial assembly.

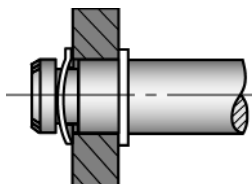

Bowed rings, for resilient end-play take-up, function as both spring and fastener.

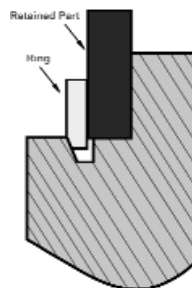

Beveled rings take up end-play rigidly, forming "wedge" between part and groove.

Rotor Clip beveled rings provide rigid end-play take-up by functioning as a "wedge" between the retained part and the load-bearing groove wall. Series VHO beveled rings have a 15° bevel on just one side of the outer circumference. Series VSH external rings also have a single bevel which is located on the inner circumference of the ring.

How the Bevel Works - When a beveled retaining ring is assembled in its groove, if there is end-play between components in the assembly, the ring's spring action causes the fastener to seat deeper in the groove, compensating for the end-play. The spring action also exerts an axial force against the retained part which can be calculated with formulas given in the Rotor Clip Catalog. Rotor Clip beveled rings are available only in ring types for axial installation

7. To Groove or Not to Groove - Most retaining rings are designed to be assembled in accurately located grooves which become an integral part of the fastening system. The groove assures proper location of the ring and contributes to its load capacity in the assembly. For many products, however, it isn't practical to cut a groove and in some designs, you don't need one. The groove is unnecessary, for example, in many electronic instruments, small appliances, toys, plastic products and other applications where the required shoulder need not absorb any sizable thrust load but rather must serve merely as a positioning and locking device against small vibrations and impacts.

Rotor Clip self-locking rings do not require any grooves, threads or other preparatory machining. They may be installed quickly and economically even by unskilled labor and - because they may be seated at any point on a shaft or in a housing - automatically compensate for accumulated tolerances in the retained parts. Series SHF retainers may be removed for product adjustment or service; the other rings must be destroyed for disassembly.

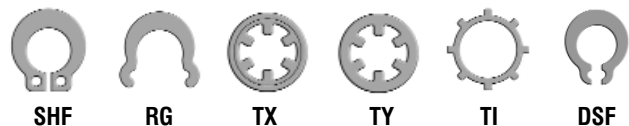

8. Assembly and Disassembly - As mentioned earlier, it is helpful for design engineers to "think ahead" about assembly before specifying retaining rings. That way you can choose rings which can be installed quickly and economically with Rotor Clip pliers, applicators and dispensers, or other simple hand tools (see pages 242-250). If you are going to design and build your own automate installation equipment, be sure to check with our technical sales department for guidelines that will help you avoid problems after your equipment is put into service.



Military Retaining Rings

ROTOR CLIP OFFERS 100% MILITARY CERTIFIED RETAINING RINGS

- DFARS Compliant
- CAGE CODE: 07382
- MADE IN USA



Rotor Clip now offers retaining rings certified to military standards in the popular materials and finishes listed below:

MATERIAL	FINISH	MS CODE	ROTOR CLIP DESIGNATION
Carbon Steel	Cadmium Plated	1	ST MCD
Carbon Steel	Zinc Dichromate Plated	2	ST MZD
Carbon Steel	Phosphate Coated	3	ST MPD
Stainless Steel	Passivated	4	SS MPS
Beryllium Copper	-	5	BC MTM

Example: Military Part converted to a Rotor Clip Part Number:

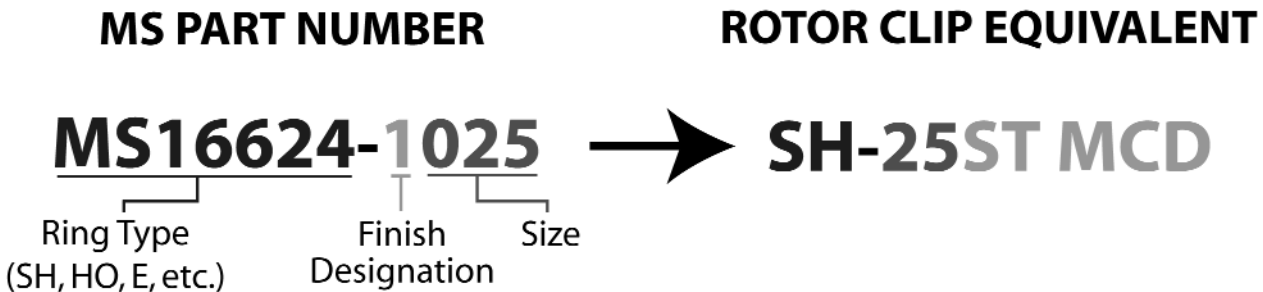

To cross reference any military retaining ring part number to a Rotor Clip part number, go to the Rotor Clip web site address below and click on the "Parts Interchange" link. Enter the complete military part number in the box shown, then click "submit." www.rotorclip.com

You can also request a quote by placing your cursor over the "Online Services" link on the left side of the page and clicking on "Request Quote."

ORDERING INFO FOR ROTOR CLIP MILITARY RETAINING RINGS:

- \$100 Minimum Order, 100 piece quantities
- Full certs provided FREE of Charge
- Certificate of Quality FREE of Charge
- DFARS Certification FREE of Charge

NOTE: Truarc LLC, a former producer of retaining rings for military and commercial use, is no longer in business. Rotor Clip purchased Truarc's assets and intellectual property. Truarc military cage code 79136 has been replaced by Rotor Clip cage code 07382.

DFARS (Defense Federal Acquisition Regulation Supplement)

ALL ROTOR CLIP STAINLESS STEEL AND BERYLLIUM COPPER RETAINING RINGS ARE DFARS COMPLIANT. FOR MORE INFORMATION, CONTACT ROTOR CLIP CUSTOMER SERVICE - SALES@ROTORCLIP.COM OR VISIT OUR WEB SITE AT WWW.ROTORCLIP.COM.



Lot Traceability/Quality

LOT TRACEABILITY / QUALITY CHECKS FOR RETAINING RINGS

Lot Number - All product sold should reflect this number so that it can be traceable to the material and processes used to make your parts. This protects you if a problem arises that requires records of the manufacturing process. (Note: the same requirement should apply to foreign suppliers as well).

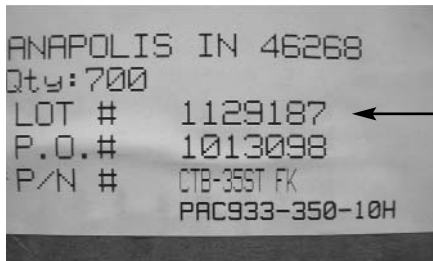

Lot
Number

Country of Origin - Like the lot number, this should be displayed prominently on any packages you receive. YOU HAVE A RIGHT TO KNOW WHERE YOUR RINGS WERE MADE.



Country of
Origin

Rust - The presence of rust is an indication that the rings have passed their shelf life and should not be used.



Rusty
Ring

Distortion - In the example below, the minimum section was not properly formed. Use of this ring can lead to a failure. Also, be sure to check for other distortions like bent and/or chipped rings.



Distortion
and Chips

Flaking Finish - Look for finish that is flaking off parts. If you see a similar condition on your retaining rings, contact your supplier. Wherever the finish is removed, the parts can potentially rust and fail.



Flaking
Finish

Critical Measurements - These include thickness, Min/Max sections, lug height and hardness. Be sure these measurements match the print or the Rotor Clip catalog specifications for that particular part.



Use a
micrometer to
measure the
thickness
dimension of
your ring

Note: The retaining rings shown in this section have not been produced by Rotor Clip Company, Inc. Most are imported rings purchased in retail stores.

Three elements are required in a typical joint design: The hose, the fitting and the clamp. These elements must meet certain performance and material specifications if they are to function successfully in a given application. Here are some points to keep in mind when addressing joint design.

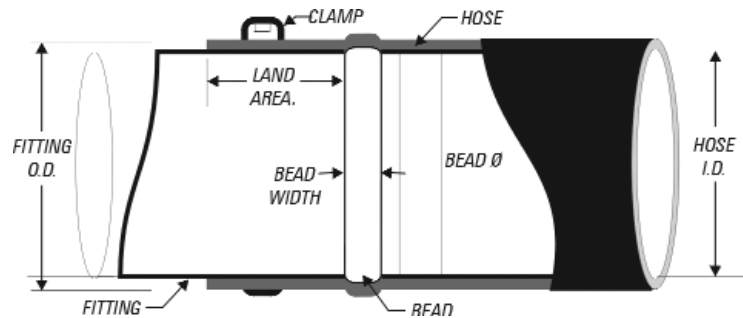

I. HOSE:

There are many types of hose constructions and materials. A common automotive type is EPDM rubber compound with a Shore A hardness of 60 durometer. Other materials of construction are silicone or a combination of EPDM and silicone. Many are reinforced with an inner layer of woven fabric.

A. The hose is named after its nominal, inside diameter. For example, a 1" hose is one with an inside diameter of 1".

B. The outside diameter depends on the wall thickness, which varies depending upon the hose type and construction. It is important to specify a hose with a closely controlled wall thickness, the smaller the tolerance the better. This will aid in sizing the clamp for the application.

C. Constant tension type clamps transmit force more easily through a hose with a thin cross section.

D. A higher hose durometer (hardness) means the hose is less compliant and more difficult to install. Lower durometer hoses allow the clamp to translate its force directly to the sealing surface of the fitting.

E. The straighter the angle of the hose, the easier it is to install.

The Society for Automotive Engineers recognizes two basic types of hoses for heater and radiator applications. They are described below. (For more detailed explanation of these and other hose types, see SAE specification J20.)

A. SAE 20R3 Heater Hose - Used for heater systems in ground transportation vehicles. Wall thickness range: for sizes less than 25.4mm, the OD is the target ID +8mm (total wall), ± 0.8 mm. For 25.4mm size, the OD is $34\text{mm} \pm 1.2$ mm.

B. SAE 20R4 Radiator Hose, Normal Service Type - Radiator hose for coolant circulating systems of automobile engines. Wall thickness range is 4.3 to 5.6mm for sizes smaller than 50.8mm and 4.3 to 6.4mm for sizes 50.8mm and larger.

II. CLAMP:

Rotor Clamp constant tension type hose clamps will compensate for changes in joint diameter due to compression set in a hose. This feature eliminates leaks and the need to re-torque a clamp.

A. Factors to consider when sizing a clamp:

- **CTB type clamps:** The clamps have a number designation equivalent to the outside diameter of the joint to be clamped, expressed in millimeters (Ex.-CTB-27).

- **HC (SAE Type "E"), HW and DW (SAE type CTW)** - Clamps have a range of recommended application diameters, listed in the catalog as "A", "B" and "C" diameters. The nominal diameter of the clamp is the clamp size divided by 16.

- The joint diameter will equal the fitting outside diameter plus twice the wall thickness, including the tolerances associated with each.

- The clamp must be large enough to fit over the maximum diameter of the joint bead and hose at this point (see illustration above).

B. You can use a smaller clamp on an application to increase force. This can be done by placing the clamp on the fitting, installing the hose and sliding the clamp "backwards" up to the bead.

C. Ideally, a clamp should be sized to fit onto the joint when opened to 90% of full (as a safety factor) and close to no less than the nominal (size) diameter when in the final position.

III. FITTING

The fitting is the portion of the joint over which the hose is installed. To reap the full benefits of a constant tension clamp joint, the fitting should have the following characteristics:

- A. The fitting should be round (within .003 inches).
- B. There should be interference between the fitting and the hose, typically between 5% and 10% of the hose inner diameter. (Ex. A 1" nominal diameter hose could have a 1.062" diameter fitting for a 6.2% interference fit. All tolerances should be considered when calculating this diameter.)
- C. The surface of the fitting should be free of pits, scratches, "dents," parting line mismatches, and any surface defect that might cause a leak.
- D. The fitting should contain a bead that will prevent slippage under conditions of pressure where the hose is not constrained.
 - The bead diameter should be sized in such a way that the clamp can be installed over the assembled joint yet provide as much interference as possible and still facilitate acceptable assembly push on force.
 - The bead width and shape should be as small as possible and still allow for easy insertion of the hose onto the fitting.
 - The bead should be symmetric and should not compromise the geometry of the joint (roundness, surface defects, etc.).
- E. The fitting must be of the design diameter for a length of approximately 15/16" (23.8mm) after the bead. That is, all dimensional constraints must be followed. This is necessary to seat the clamp. This means any bends, twists, diameter changes or the like can not occur until after the area in which the clamp will seat.

IV. ASSEMBLY

- Clamps should be installed with specific pliers recommended for the type of clamp being used.
- Expansion of the clamp beyond the intended operating diameter will diminish the force that the clamp can apply.
- Any lubricating substance used to aid assembly of the hose must never be in contact with the clamp.
- Such lubricants in contact with a clamp can enable a mechanism for hydrogen migration, causing failure through material fracture.
- Examples of lubricants known to cause clamp failure include acetone, chlorine, flourine, mineral oil, dish detergents, and laundry detergents.



ROTOR CLIP Trademarks



TRUARC



Designed for Quality



Rotor Clip Company, Inc.® - World Headquarters

187 Davidson Avenue, Somerset, NJ 08873
1-800-557-6867 • +1 732-469-7333 • Fax: +1 732-469-7898
www.rotoreclip.com

Rotor Clip Limited®

Unit 6, Meadowbrook Park, Holbrook, Sheffield, S20 3PJ United Kingdom
+44 (0) 114 247 3399 • Fax: +44 (0) 114 247 4499
e-mail: rc ltd@rotoreclip.com
www.rotoreclip.co.uk

Rotor Clip GmbH®

Buchwiese 3, D-65510 Idstein/Taunus Germany
+49 (0) 6126 227360 • Fax: +49 (0) 6126 2273619
e-mail: rcgmbh@rotoreclip.com
www.rotoreclip.de

Rotor Clip Czech a.s.

Pražská 403, CZ-411 18 Budyně nad Ohří
+420 416 863 168 • Fax: +420 416 863 193 • e-mail: rotorclipcz@rotorclip.com
www.segnor.cz

Rotor Clip Shanghai Rep Office

Room 1510~1511, JH Plaza, 2008 Huqingping Road
Shanghai, 201702 People's Republic of China
Tel: 001 7324697333 * 4101
Mobile: +86 13601784145
www.rotoreclip.com

